



UD TRUCKS

OWNER'S MANUAL

QUESTER Series



The name **Quester** means searcher and **Quester** is truly a truck for searchers of new fresh experiences and business opportunities.

Truck operators today face challenges of increasing fuel prices, environmental legislation and challenging road conditions. Ultimately, the real winners are the ones who keep on running. Like a long distance runner: consistently and reliably, mile after mile, year after year. **Quester** delivers what transport companies around the globe and drivers are looking for: an affordable real heavy-duty truck that combines first-class fuel efficiency with reliable durability.

Quester is **UD Trucks** most cost-efficient truck ever. Not only when you buy it, but also when you drive it.

FOREWORD

Congratulations on your wise decision to be the proud owner of a **Quester**, enabling you to reach the extra mile. This truck is delivered to you with confidence which is produced using the latest technology and strict quality control during production and delivery.

Before driving your truck, please read through the Owner's manual before you drive the truck for the first time. This will ensure you to familiarise the controls and maintenance procedures, assisting you in the safe operation providing room for efficient driving of the vehicle. However the safety devices installed in the vehicle and the information provided does not form a replacement for careful driving with care and common sense, the driver or user is totally responsible for the safety of self, vehicle and road, failing which **UD Trucks** cannot be held responsible in any manner.

It is strongly recommended to use **UD Genuine Parts** and carry out all the periodic maintenance, service, repair at an **UD Trucks** authorised dealer to prolong life of the vehicle and reduce maintenance cost. In order to retain the safety, reliability and long life of the vehicle **UD Trucks** recommends you to heed our advice regarding the driving and care of your vehicle. For all your queries on service, maintenance, use of genuine spares, oils, fluids, procedures, contact your nearest **UD Trucks** authorised dealer.

All information, illustration, operations, maintenance, data provided in this manual is based on the latest model available during the preparation and printing of this manual. As a part of continuous product optimisation, **UD Trucks** reserves the right to change, modify, remove or add features in the vehicle and manual. This manual includes information on all the options available in the truck for all models. Therefore you may find some information not applicable for your models.

A separate warranty manual is provided along with this manual when purchasing the truck, explaining the warranty and service details of your vehicle. The Owner's manual and Warranty manual is an integral part of the vehicle that forms a basic record of your vehicle which should be maintained and retained in a proper manner with the vehicle at all times.

In the event of the vehicle being sold, please ensure that this manual is left in the vehicle for the reference of the new owner.

This Quester is equipped with software systems which record various information about the vehicle (machine/engine) and this information is transferred from the vehicle to **UD Trucks** and used by **UD Trucks** and its authorized dealers in the product development process and for possible malfunction detection.

TABLE OF CONTENTS

1.INTRODUCTION AND SAFETY.....1.1

1.1 Introduction.....	1.1
1.2 Vehicle identification.....	1.6
1.3 Before driving.....	1.10
1.4 Starting the engine.....	1.12
1.5 Vehicle speed limit.....	1.13
1.6 Parking.....	1.16
1.7 When there is a problem.....	1.17
1.8 Cab tilting.....	1.18
1.9 Overheating.....	1.19
1.10 Handling the fuel filter and fuel tank.....	1.20
1.11 Handling of the battery.....	1.22
1.12 Other precautions.....	1.23
1.13 Modification and replacement.....	1.24
1.14 Washing the vehicle.....	1.26
1.15 OBD (On board diagnostics).....	1.27
1.16 Driving trucks with Euro IV/China IV engines.....	1.30
1.17 Telematics gateway.....	1.31

2.GETTING IN AND OUT OF THE CAB2.1

2.1 When getting into the cab.....	2.1
2.2 Doors.....	2.3
2.3 Seats.....	2.5
2.4 Seat belts.....	2.11
2.5 Steering wheel adjust.....	2.12

3. EQUIPMENT DESCRIPTION AND OPERATION..... 3.1

3.1 Instrumentation.....	3.1
3.2 Indicators.....	3.5
3.3 Display menu.....	3.9
3.4 Switches.....	3.15
3.5 Combination switch.....	3.22
3.6 Gear shift lever.....	3.27
3.7 PTO - If equipped.....	3.29
3.8 Fuel coaching system.....	3.35
3.9 Fifth wheel operation.....	3.38
3.10 Differential lock.....	3.43
3.11 Bogie control - If equipped.....	3.46
3.12 Coupling - If equipped.....	3.48
3.13 Others.....	3.50

4.ACCESSORIES AND AUDIO 4.1





4.1 Accessories.....	4.1
4.2 Audio front panel - if equipped.....	4.4
4.3 Audio.....	4.5
4.4 Radio.....	4.6
4.5 USB player.....	4.7
4.6 Setup.....	4.8
4.7 Check before requesting service.....	4.9

5. AIRCONDITIONING	5.1	8.17 Washing the vehicle	8.63
5.1 Ventilation	5.1	8.18 Handling of exhaust.....	8.65
5.2 Air conditioner	5.3	8.19 Fifth wheel	8.68
6.DAILY INSPECTION	6.1	8.20 Vehicle storage.....	8.70
6.1 Areas to inspect	6.1	8.21 Greasing.....	8.71
6.2 Inspection instructions	6.2	9.MAINTENANCE SCHEDULE	9.1
7.CORRECT DRIVING OPERATION.....	7.1	9.1 Overview.....	9.1
7.1 Correct driving operation.....	7.1	10.EMERGENCY PROCEDURES.....	10.1
7.2 Operation precautions.....	7.3	10.1 When there is problem	10.1
7.3 Driving under special conditions	7.16	10.2 Jump start.....	10.5
8.INSPECTION AND MAINTENANCE.....	8.1	11.SERVICE DATA.....	11.1
8.1 Inspection and maintenance	8.1	11.1 Maintenance standard.....	11.1
8.2 Air cleaner.....	8.4		
8.3 Engine oil filter	8.9		
8.4 Fuel filter	8.10		
8.5 Air bleeding of fuel system.....	8.16		
8.6 Battery.....	8.17		
8.7 Tyres	8.18		
8.8 Jack up.....	8.27		
8.9 Lights and fuses	8.30		
8.10 Mirror.....	8.39		
8.11 Coolant.....	8.40		
8.12 Brake.....	8.43		
8.13 Tools	8.49		
8.14 Oils.....	8.50		
8.15 Coupling.....	8.59		
8.16 Wiper blade.....	8.62		

When reading the manual

In this manual, read carefully those sections which have signs.

“**DANGER**”, “**WARNING**”, “**CAUTION**” and “**NOTE**”. These signs are particularly important.

 DANGER	Indicates a potentially dangerous situation that, unless avoided, will lead to death or serious personal injury.
 WARNING	Indicates a potentially dangerous situation that, unless avoided, may lead to fatal injury, serious personal injury or damage to the product.
 CAUTION	Indicates a potentially dangerous situation that unless avoided may lead to minor or moderate personal injury or damage to the product.
NOTE	Indicates a situation, use or circumstance that should be emphasised.
	This symbol indicates a practice which is not recommended and should not be carried out.

The Owner's Manual contains information you need to operate and maintain your truck to the highest possible standards. Follow the instructions and advice in this manual, Some of the equipment described in this manual is optional and may not be included in your vehicle. If you have any questions, please consult your nearest **UD Trucks** authorised dealer. The specifications and illustrations in this binder are not binding and **UD Trucks** reserve the right to change them at any point of time without prior information.

The safety instructions provided in this manual are only a few of the vast and it unlimited in reality, hence it is the sole responsibility of the user to check all possibilities on safety before handling the vehicle, driving, performing a maintenance operation or service procedure. However the safety information provided in this manual does not form a replacement for careful driving and operation with caution and common sense, the user is totally responsible for the safety of self, vehicle and road, failing which **UD Trucks** cannot be held responsible in any manner.

This manual covers the feature for both LHD and RHD models. To enhance the understanding of the user, both LHD and RHD illustrations are shown in a single topic. The illustration in the left side corresponds to the LHD vehicle and right side corresponds to the RHD vehicle, until and otherwise mentioned.

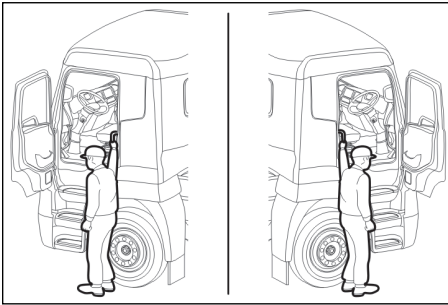

LHD Vehicle

RHD Vehicle

Topics common to both LHD and RHD are made available as a single illustration.

The illustrations shown in this manual are not contractual and may not reflect actual situation. If need of clarification please consult your nearest **UD Trucks** authorised dealer.

1.INTRODUCTION AND SAFETY

1.1 Introduction

This manual provides detailed explanations for working with **QUESTER** series vehicles as below

TRACTOR	4 X 2	6 X 2	6 X 4	
RIGID			6 X 4	8 X 4
ENGINE	GH11E			

Please read through and understand the Owner's manual before you drive the truck for the first time.

1.INTRODUCTION AND SAFETY

Abbreviations

ABS	Anti-lock Brake System	POC	Power train Operating Condition
AC	Air Condition	PTO	Power Take Off
ACM	After treatment Control Module	RES	Resume
ADR	European Agreement Concerning the International Carriage of Dangerous Goods by Road	RHD	Right Hand Drive
CC	Cruise Control	RPM	Revolutions Per Minute
ECU	Electronic Control Unit	RSL	Road Speed Limit
EMEA	Europe, Middle East and Africa	SEA	South East Asia
EMS	Engine Management System	SI	International System of Units
EOL	End Of Line	TGW	Telematics Gateway
FRS	Function Requirement Specification	VIN	Vehicle Identification Number
GAW	Gross Axle Weight		
GCC	Gulf Cooperation Council		
GH11E	11 liter Engine		
GVW	Gross Vehicle Weight		
HMI	Human Machine Interface		
HVAC	Heating, Ventilating and Air Conditioning		
IC	Instrument Cluster		
IECU	Integrated Electronic Control Unit		
ISO	International Standardization Organization.		
LHD	Left Hand Drive		
MIL	Malfunction Indicator Lamp		
NA	Not Applicable		
NOx	NOx is a generic term for mono-nitrogen oxides NO and NO2 (nitric oxide and nitrogen dioxide).		
OBD	On Board Diagnostics		
PCB	Program Control Board		

For safe operation

The operation and points that require caution during handling of the vehicle for a trouble-free and worry-free use of the vehicle has been listed here. Read the informations before using the vehicle.

CAUTION

Pay attention to the different labels on the vehicle for safety.

Weights and measures

This manual uses SI units with their respective metric system equivalents in braces.

Fuel

CAUTION

Use fuel that fulfil legal requirements and national and international standards. Failure to comply will lead to damage the engine and cause excessive exhaust emission.

CAUTION

Petrol (gasoline) and alcohol should never be mixed with diesel fuel.

The composition of fuel plays a vital role in the function, service life and emission of the engine. In order to achieve specified levels of performance with regard to power, fuel economy and to fulfil emission legislations. Use fuel that meets all the legal requirements and also the national and international standards. These standards are the minimum requirements for commercial fuel and are frequently prepared in consultation with the oil companies and the automotive industry. Examples are:

- **GB 19147-2013**
- **EN590 (with nationally adapted cold requirements)**
- **JIS KK 2204**

NOTE

The fuel injection unit should not be adjusted to compensate for any loss of power.

These fuels perform better exhaust emissions than standard fuels and can therefore be recommended.

Water and particles

Make sure that water particles do not enter the fuel tank and get mixed with the fuel, entry of water particles will corrode the fuel injection unit. Water facilitates the growth of bacteria and mould in the tank, which will filter blockage. In cold weather, water dispersed in the fuel can freeze and block the fuel supply. Check the fuel tank cap, fuel level sensor mounting area for proper sealing.

1.INTRODUCTION AND SAFETY

Diesel boosters

Many manufacturers of commercially available additives (so called diesel boosters) promise reduced fuel consumption and improved lubricity, although they do not have any demonstrable effect whatsoever on either fuel consumption or lubricity.

UD Trucks does not accept any responsibility for warranty claims if these additives have been used and it is not **UD Trucks** policy to use, test or evaluate these additives.

NOTE

It is not permissible to add any kind of diesel boosters to the fuel.

Fire extinguisher

The instructions for handling the fire extinguisher (if equipped) are described on the equipment itself. The driver or user has to familiarise the instructions for handling the fire extinguisher to use it properly in an emergency situation. Fire extinguisher is located between the passenger seat and the door on the floor. The fire extinguisher must be refilled immediately at an **UD Trucks** authorised dealer after use, even if it has not been completely discharged.

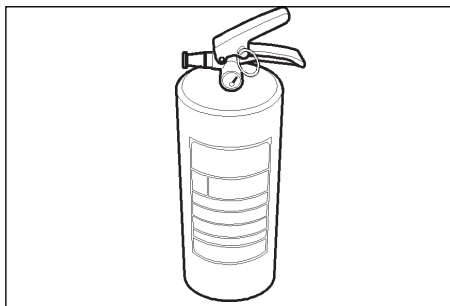

NOTE

Periodically check that the pressure gauge needle is in the green range. The vehicle owner is responsible for maintaining the fire extinguisher. To ensure that it is always ready for use, the vehicle owner must follow the manufacturer's instructions printed on the fire extinguisher.

Warning triangle

The truck has warning triangle stored in glove compartment box in high roof cab's and in the head console for standard cab's.

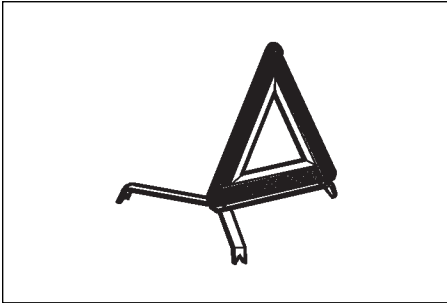

Roof hatch -If equipped

To open the roof hatch, push up the latch handles. It can be opened from one side (front or rear) or both sides of the hatch at the same time. To close it, just pull it back to its original position.

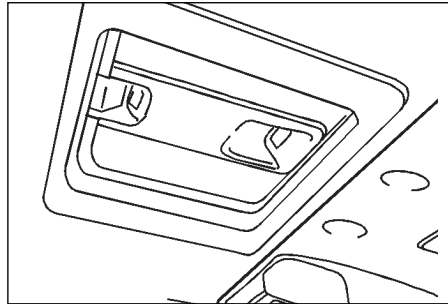

1.INTRODUCTION AND SAFETY

1.2 Vehicle identification

Vehicle identification plate



Vehicle identification plate is located just above the first step on the right hand side of the truck, open the door to view the vehicle identification plate.

VIN Location

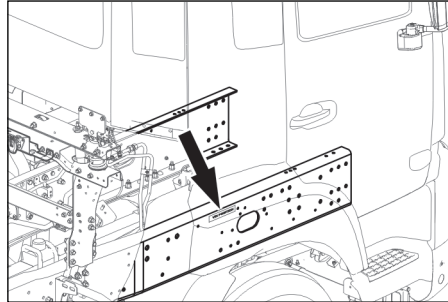

VIN number is punched on the chassis frame front, on right hand side.

VIN Plate SEA and EMEA

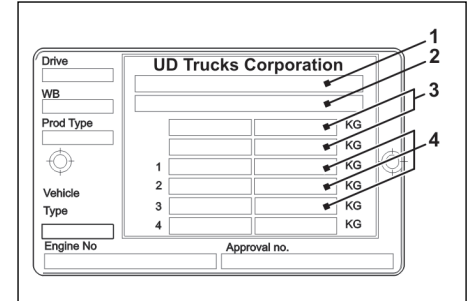

UD Trucks Corporation	
Drive	
WB	
Prod Type	
Vehicle Type	
Engine No	Approval no.

1: Type approval no. for SEA market and chassis no. for EMEA market
2: VIN number
3: Technical maximum weight
4: Maximum technical axle load

VIN Plate Rigid - China

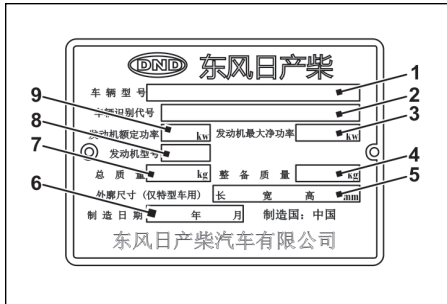

- 1: Vehicle model
- 2: VIN number
- 3: Technical maximum weight
- 4: Maximum technical axle load
- 5: Length width height
- 6: Year month
- 7: Technical maximum weight
- 8: Engine model
- 9: Engine rated power

VIN Plate Tractor - China

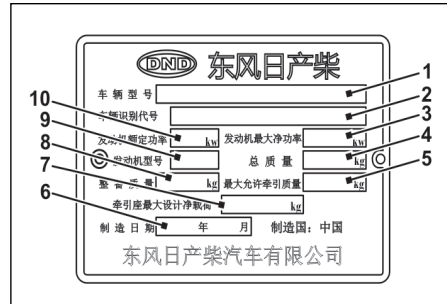

- 1: Vehicle model
- 2: VIN number
- 3: Engine maximum net power
- 4: The total mass
- 5: Maximum allowable takeoff weight
- 6: Year month
- 7: Maximum design load
- 8: Curb weight
- 9: Engine model
- 10: Engine rated power

VIN Plate Rigid - GCC

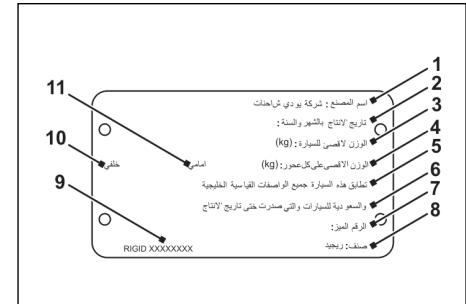

- 1: Vehicle manufacturer
- 2: Year month
- 3: GVW
- 4: GAW
- 5: This vehicle applicable to all Gulf/Saudi
- 6: Vehicle standards in effect up to the date of
- 7: VIN
- 8: Category
- 9: Part number
- 10: Rear
- 11: Front

1.INTRODUCTION AND SAFETY

VIN Plate Tractor - GCC

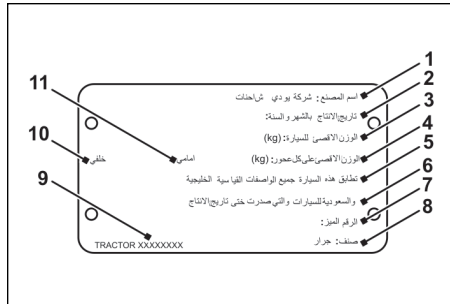

- 1: Vehicle manufacturer
- 2: Year month
- 3: GVW
- 4: GAW
- 5: This vehicle applicable to all Gulf/Saudi
- 6: Vehicle standards in effect up to the date of
- 7: VIN
- 8: Category
- 9; Part number
- 10: Rear
- 11: Front

Engine identification

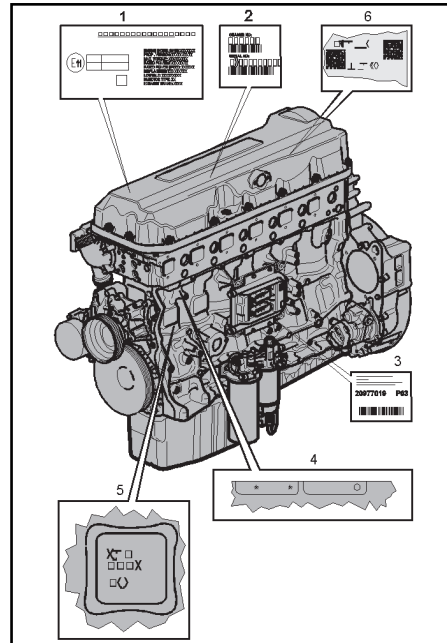

- 1. Decal engine identification
- 2. Chassis no. and serial no.
- 3. Engine system data
- 4. Engine serial number
- 5. Engine block casting data
- 6. Manufacturing date

Transmission gearbox identification plate location

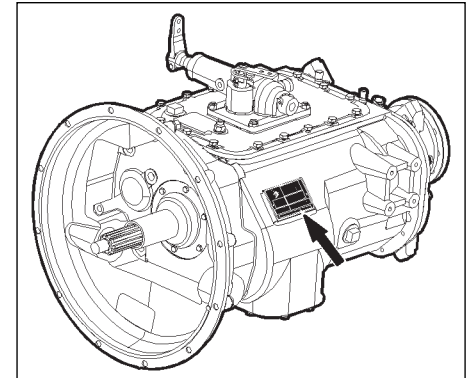

6 Speed transmission gearbox

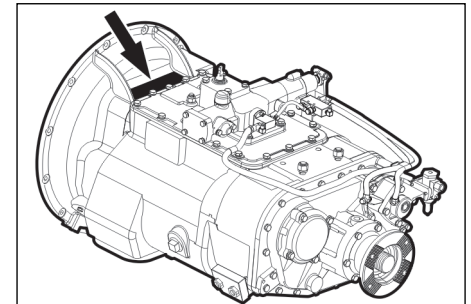

9 and 12 Speed transmission gearbox

1.INTRODUCTION AND SAFETY

Axle identification plate location

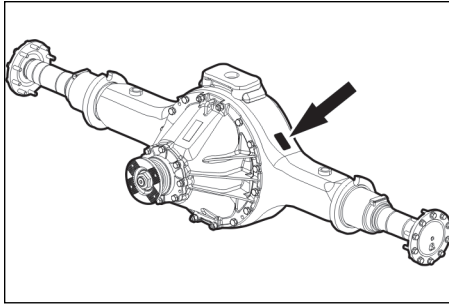

Solo axle

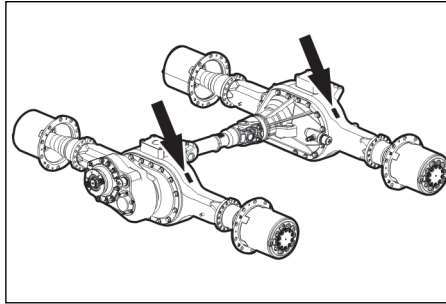

Tandem axle, Hub reduction

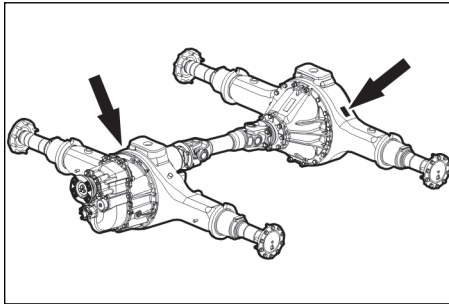

Tandem axle

Battery plate location

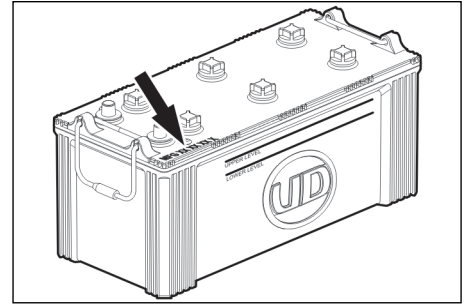

150 Ah

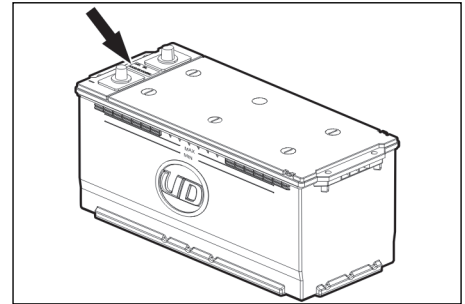

165 Ah and 180 Ah

1.INTRODUCTION AND SAFETY

1.3 Before driving

Getting in and out of the seat
When opening the door

 **DANGER**

Opening the door without required care and caution is dangerous and it could lead to an accident.

Before opening the doors, check both the front and sides of the vehicle, open the door ensuring after it is safe.

Seat position and steering wheel position

 **WARNING**

Do not adjust the seat or the steering while driving. Failure to comply can lead to accidents.

Adjust the seat and steering wheel to the correct driving position only when the vehicle is stopped.

Do not hang accessories from the windshield or other areas.

 **WARNING**

Do not hang accessories or decorations from the windshield or attach seals and films to it. Doing so can block the driver's vision.

Do not place items on the instrument cluster or the dashboard.

 **WARNING**

Do not drive with loose items placed on the instrument cluster or the dashboard. These tend to fall while driving and distract the driver's attention can lead to an accident.

1.INTRODUCTION AND SAFETY

Wearing and adjusting the seat belt

Always wear the seat belt before driving and the user should also wear the seat belt.

WARNING

Do not fasten or remove the seat belt while driving, it is very dangerous.

Accelerator pedal and brake pedal

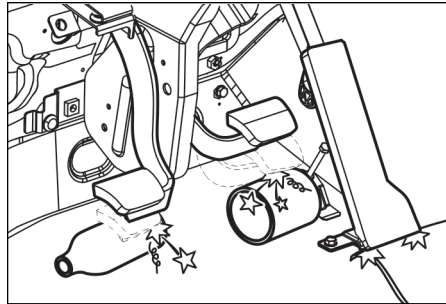

WARNING

Do not place loose objects such as tools, cans, bottles, mats, etc on the cabin floor. They can roll underneath the pedals and prevent their effective operation could lead to accidents.

Do not carry dangerous goods

WARNING

Do not carry containers containing dangerous explosive, flammable goods in the vehicle cab. This is dangerous and could cause serious fire hazards.

Before starting the engine

Before starting the engine, shift the transmission to the neutral position and make sure that the parking brake is applied.

1.INTRODUCTION AND SAFETY

1.4 Starting the engine

Be cautious of exhaust gas

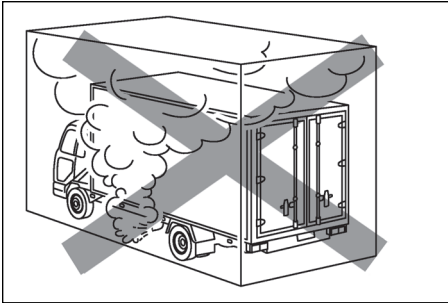

WARNING

Do not idle the vehicles in a closed shed or under poor ventilation, leading to inhalation of harmful exhaust gases.

Starting precautions

NOTE

- When starting the vehicle, make sure that the area is free from obstacles around the vehicle.
- There are areas that cannot be checked using the vehicle mirrors. When stopping or starting the vehicle be conscious of the area around the vehicle and ensure it is safe.

1.5 Vehicle speed limit

Speed limiter - if equipped

WARNING

Always drive as per the road speed limit regulation by the local authorities.

Vehicles equipped with speed limiter cannot be accelerated beyond the set values by pressing the accelerator pedal. **RSL** icon in the display will pop up mentioning the vehicle has reached its maximum speed. The vehicle may be equipped with the following speed limiter range.

1. 60 km/hour
2. 80 km/hour
3. 90 km/hour
4. Without speed limiter

Driver information displays

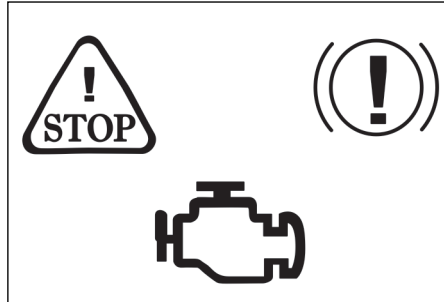

WARNING

Be conscious of the driver information displays. If the warning lights illuminate while driving do not ignore and continue to drive. This might lead to a malfunction or could be lead to accident. Stop the vehicle immediately in a safe location and contact the nearest UD Trucks authorised dealer.

Foot brake long-term use

Avoid using the foot brake continuously for an extended period of time, to avoid reduction in braking effect. Do not rest the foot on the brake pedal while driving.

1.INTRODUCTION AND SAFETY

Cruise control - If equipped

WARNING

Using cruise control does not allow the driver to shift the concentration from the road. The driver or user is responsible for safety of self, vehicle and road.

CAUTION

Do not use the cruise control on wet or snowy roads, while raining, hilly terrain, regions with heavy traffic or on slippery roads, turns and bends.

The cruise control option is used in favorable driving conditions to reduce fuel consumption and driver fatigue.

Auxiliary brake

CAUTION

Avoid having auxiliary brake continuously applied on slippery roads to avoid skidding.

Use the auxiliary brake when descending hills and during gentle braking.

Parking brake lever operation

WARNING

Do not operate the parking brake lever while driving. It can lead to unstable driving.

Do not switch OFF ignition while driving

WARNING

Do not switch "OFF" the ignition while driving. It is dangerous and should not be done. Compressed air will not be supplied to the brakes when the engine is OFF, which will lock the brake pedal making it unusable. The steering assist mechanism will also not work, making it impossible to turn the steering wheel which could lead to accidents.

Do not use the bed while driving



WARNING

If the bed is used while driving, the person could be thrown around during a collision or emergency braking.

Air conditioner operation



DANGER

Do not switch on the air conditioning system and sleep or stay for a prolonged time in the vehicle with windows closed. Failure to comply can lead to death due to non availability of oxygen.

Leaving the air conditioner set to “**recirculation mode**” for a long period of time will cause the windows to fog up and impair visibility. Switch to “**fresh air mode**” and continue driving after the fog is cleared.

1.INTRODUCTION AND SAFETY

1.6 Parking

When parking



CAUTION

Avoid parking the vehicle under trees to avoid bird droppings falling on the vehicle, bird droppings are acidic and will cause the paint to wear out. Avoid parking under trees which shed fruits, tree sap which can damage paint jobs.

1.7 When there is a problem

Flat tyre while driving

⚠ DANGER

Do not drive with a flat tyre. Driving with flat tyre is dangerous can lead to accidents.

When towing

⚠ WARNING

The brakes and steering system will not work when the engine is OFF. Use only tow truck to tow the vehicle.

⚠ CAUTION

If the vehicle needs to be towed, the propeller shaft should be disconnected, to avoid damage to transmission.

When using jumper cables

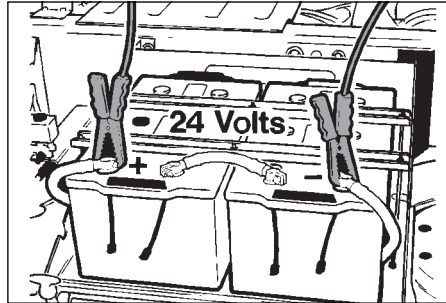

⚠ DANGER

Do not jump start the vehicle without proper knowledge. Contact the nearest UD Trucks authorised dealer for assistance.

When changing the tyre

⚠ WARNING

While changing the tyre, lift the vehicle on a stable and hard level surface, where the jack can be used safely. Using the jack on sloped or soft surfaces could cause the jack to tip over and the vehicle to drop.

1.INTRODUCTION AND SAFETY

1.8 Cab tilting

Safety



WARNING

Tilt the cab completely. Do not work underneath a cab while tilting or under half tilted condition.



CAUTION

Front panel of the vehicle should be opened before tilting the cab in order to prevent possible interference with parts of the bumper.

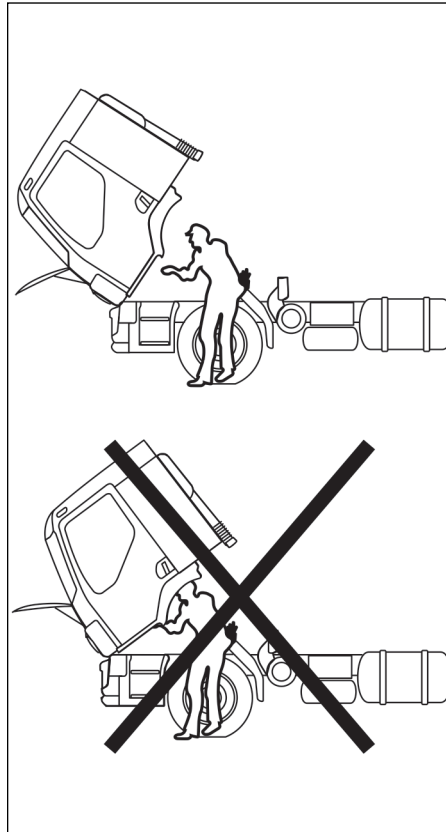

Check the following when tilting the cab

- there is sufficient space in front of the cab and free from obstacles.
- there is sufficient building height to occupy the tilted cab.
- the transmission gear lever is in neutral position.
- the parking brake is applied.
- Remove loose and heavy object in the cab and close the glove box and all doors.
- Chock the wheels.

1.9 Overheating

When the vehicle overheats

WARNING

Do not fill coolant, when the engine is hot, to avoid burns from steam and hot coolant. Allow the engine to cool completely before filling the coolant.

CAUTION

Let the engine cool at idling speed before switching off the engine.

After a heavy loading the engine must be cooled down by running it at idling speed before switching off. This avoids heat stress in the engine and the hot components have time to cool down. For example, the turbocharger.

Handling the radiator cap

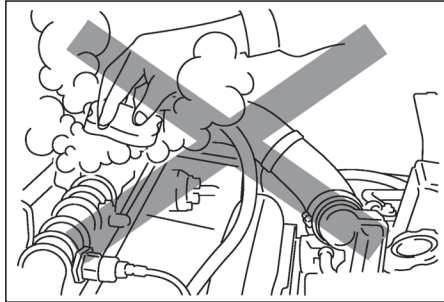

WARNING

Do not touch the radiator cap when the engine is hot or immediately after driving. The cap will be hot and if opened, steam or hot water will spray causing burns.

Oil inspection and changes

WARNING

Do not inspect, supply, or change engine, transmission, or differential gear oil immediately after driving to avoid burns from hot oil. Change the oil when the engine is cool.

NOTE

Drain the oils when they are warm as it flows easily.

1.INTRODUCTION AND SAFETY

1.10 Handling the fuel filter and fuel tank

When replacing the fuel filter

WARNING

Ensure that fuel filter is installed correctly. make sure there is no fuel leak from the filter, fuel leak can be dangerous and cause a fire if not rectified.

Air bleeding of fuel system

CAUTION

If air gets into the fuel system, it will cause inconsistent fuel injection and possible engine malfunction. Ensure that the air is bled from system while changing the fuel filters or when the fuel lines are disconnected.

Water draining of fuel filter

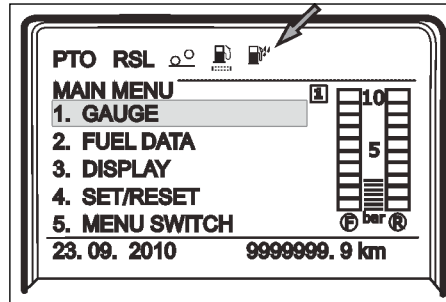

CAUTION

If water enters into the fuel system, it will cause operation malfunction and other problems. Drain the water whenever the IC display shows the warning.

Amount of fuel

Try to fill fuel early in order to always keep the tank full. This prevents condensation from getting into the fuel tank and the vehicle from running out of fuel. Ensure proper care to keep water and dust away from tank when fueling.

Refueling at self-service stand

WARNING

Do not use cell-phone while filling the fuel, it could be dangerous.

WARNING

Do not smoke, light matches, or use lighters while refueling. failure to comply could lead to fire.

When refueling at a self-service stand, be sure to observe the following items to prevent an accident such as a fire caused by static electricity or spilling the fuel.

- Make sure that the engine is switched OFF.
- Before opening the fuel filler cap, be sure to touch a metal part to eliminate static electricity.
- Only 1 person should perform the fueling.

- Securely insert the nozzle to the filler port. The auto stop does not operate when removing the nozzle temporarily to top up the fuel. It is dangerous because the fuel may be spilled in such cases.
- Please observe the precautions posted on the self-service stand, If the filling cannot be performed normally, call the station attendant and obey their instructions.

Fuel piping

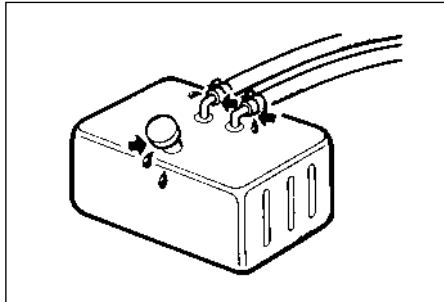

Ensure that there are no fuel leaks from the fuel tank and fuel pipes. If there is a fuel leak, contact nearest **UD Trucks** authorised dealer for assistance.

1.INTRODUCTION AND SAFETY

1.11 Handling of the battery

When charging the battery

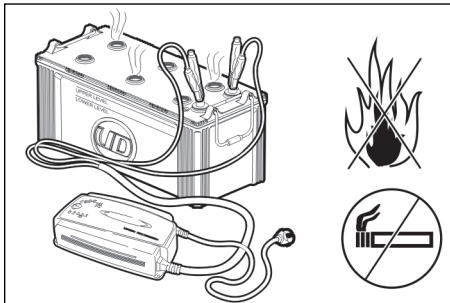

WARNING

Keep flame and heat away from the battery during charging. The hydrogen gas generated during charging could ignite and cause an explosion.

Battery terminals

CAUTION

Loose or corroded battery terminals will make it difficult to start the engine and charge the battery, which will shorten the life of the battery. Connect and secure the battery cables. Apply petroleum jelly to terminals.

In cold climates

CAUTION

Leaving the battery discharged will make it easier for the battery fluid to freeze, which could damage the battery. Keep the battery filled with battery fluid and charged periodically.

1.12 Other precautions

When closing the windows

⚠ WARNING

Make sure that no body parts are extended outside the window while operating the switch. Failing to do so might result in injuries.

Drive belt tension inspection

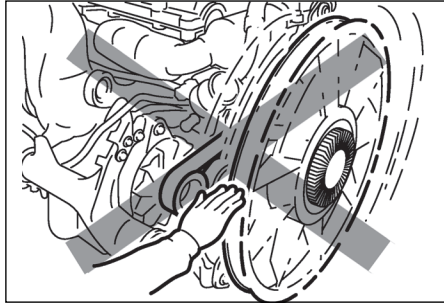

⚠ DANGER

Do not inspect drive belt while engine running.

Ensure care with the drive belt and other rotating parts, while engine is running.

1.INTRODUCTION AND SAFETY

1.13 Modification and replacement - Pneumatic and electrical system

Do not modify

 **WARNING**

Installing parts that are unsuitable for the vehicle's performance and function could lead to a malfunction or an accident.

Contact the nearest **UD Trucks** authorised dealer for advice before installing any accessories.

Do not modify pneumatic units.

 **CAUTION**

Do not add or modify the pneumatic units in the vehicle. Contact the nearest **UD Trucks** authorised dealer for advice before installing any accessories.

Electrical welding work.

 **WARNING**

Welding must be performed with great accuracy in order to obtain a proper joint. Caution must be exercised in order to avoid injuries and accidents.

When performing electrical welding, the electric current of the welding machine could flow back into the ground circuit and damage the electrical control unit; preventing it from functioning normally, so be sure to observe the following items.

1. Turn the starter ignition switch to the OFF position
2. Disconnect the battery's negative (-) terminal.
3. Be sure to ground the welding unit close to the weld contact area.

4. When the work is complete, check to make sure that all units are functioning normally.
5. Contact nearest **UD Trucks** authorised dealer for advice before performing electrical welding.

Do not perform self wiring

WARNING

Do not perform any unauthorised wiring or install electrical devices. Doing so could result in electrical component malfunctions or wiring overheating that could result in a fire.

Contact the nearest **UD Trucks** authorised dealer for advice before installing any accessories.

Replacement of fuses

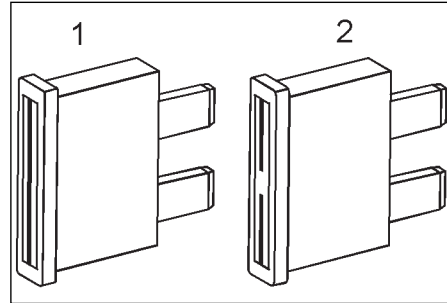

1 Fuse OK

2. Burned Fuse

CAUTION

Never use a wire in a blown out fuse, change a new fuse according to the specified capacity.

CAUTION

Do not remove the fuse from another circuit as a temporary solution. Doing so will cause the circuit of the removed fuse to stop functioning.

Replacement of lights

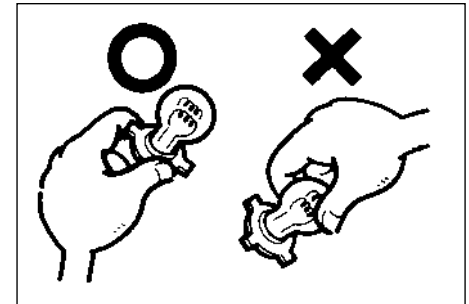

CAUTION

Use UD Genuine Parts when replacing bulbs. Using non-genuine parts or bulbs other than those of the specified capacity will result in a malfunction or device damage.

CAUTION

Do not touch the glass portion of the lamp (headlight) bulbs. Doing so will reduce the life span of the bulbs.

1.INTRODUCTION AND SAFETY

1.14 Washing the vehicle

When washing the vehicle

When washing the vehicle's undercarriage, do not directly apply steam or water from a high pressure washer on the steering shaft joint, front axle drag link and tie rod dust covers.



CAUTION

While washing, ensure that no water seeps into the electrical components like starter motor, alternator, sensors, relays and electronic units.

1.15 OBD (On board diagnostics)

General

UD Trucks uses SCR technology (Selective Catalytic Reduction) catalytic emission control to fulfil the requirements of the Euro IV/China IV or any other equivalent standards. There is a legal requirement in monitoring the emission standards. The regulation means that in addition to existing OBD-system there must also be a special level and diagnostic system for the engine's exhaust after treatment systems, so-called NOx regulatory monitoring (NOx = nitrous oxides).

NOx control monitoring system is to monitor:

- The level of NOx in the exhaust.
- The level of AdBlue in the tank.
- Faults in the emission control monitoring system.

The following effects will occur if faults are detected in the exhaust gas after treatment

- The monitoring system will inform the user through warning lamps and fault messages.
- “Non-erasable fault codes” are set.
- Possible derating of the engine (depending on type of fault)
- The information is also provided in the form of telltale indicators, pop up message when the AdBlue level is low. Also the user can view the current AdBlue level from the display.

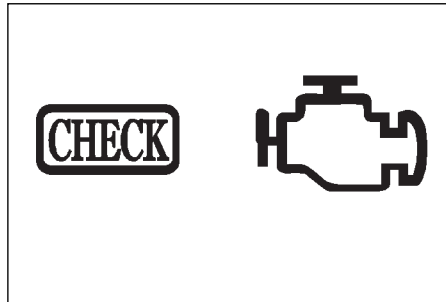

Conditions

The NOx control monitoring system is active under the following conditions only

- Ambient temperature is between -7° C to + 40° C.
- The altitude above sea level is less than 1600 m.
- Coolant temperature is above 70° C.

In order for a “non-erasable fault code” to be set (activated), a number of different basic conditions must be fulfilled. The conditions vary depending upon which fault is displayed. There are three different faults that generate a “non-erasable fault code”:

1. Empty AdBlue tank.
2. NOx level exceeding the certified level.
3. The NOx level cannot be monitored.

1.INTRODUCTION AND SAFETY

Non-erasable fault codes

The new fault codes for NOx once the fault code is reported (becomes active) it will be stored for 400 days and will not be erased, even if the current fault is remedied and the fault code becomes inactive. Once a “non-erasable fault code” is generated, an estimation is made of the amount of time the engine was running whilst the current fault was active. In this way, information about how long the engine was running with a fault in the emission system can be obtained.

Derating (power reduction)

A new feature for NOx control monitoring process means that when certain limits occur or a certain fault arises in the exhaust gas after-treatment system, a power reduction of 40% will occur. Before derating occurs, the control and warning lights will light and the instrument display will inform that derating will occur. Derating will be activated once the vehicle has stopped for the first time

(with the engine running) after the occurrence of the fault, for example at the next red light. As soon as the reason for the power reduction has ceased, the power reduction will be deactivated the next time the engine goes to idle.

Power reduction occurs during any of the following events:

- NOx level exceeding the certified level.
- AdBlue tank empty.
- The system could not monitor the NOx level during 50 hours of engine operation.

Exhaust cleaning

The engine is equipped with an exhaust gas cleaning system that cleans the exhaust gases using the AdBlue. AdBlue is injected into the exhaust system between the turbo and silencer with built-in SCR catalytic converter. The catalytic converter is used to reduce emissions of nitrogen oxides and particulates in the exhaust gases.

Fuel

Sulphur-free fuel (<10 ppm) must be used in order to ensure that the emission requirements are fulfilled at a sustained level for the Euro IV/ China IV trucks.

AdBlue (Urea solution)



AdBlue that has been modified or replaced with another liquid that does not comply with ISO 22241-1, will lose its intended cleaning effect and can damage the SCR system, making the warranty void.



AdBlue is very corrosive and can damage electrical connectors. If AdBlue gets into electrical connectors or wiring, they must be replaced. Cleaning electrical items is not enough.

The urea solution is sold under the AdBlue brand name. It is a colourless liquid consisting of urea and distilled water. It may have a slight odour of ammonia. The concentration of urea in AdBlue is 32.5%. AdBlue fulfils the ISO standard 22241 (formerly DIN 70070) and is the only urea solution approved by **UD Trucks** for refilling in **UD Trucks** with Euro IV/China IV engines. AdBlue can also be sold and marketed under other names depending on the distributor and can be used as long as ISO standard 22241 is fulfilled.

AdBlue is not dangerous but should be handled with caution. If AdBlue is accidentally spilled on the truck, rinse with water and then wipe with paper or cloth. The solution can be aggressive when it gets hot and can then damage e.g. adjacent connectors, cables and hoses in the event of leaks.

AdBlue freezes at $-11\text{ }^{\circ}\text{C}$ approximately. This is not a problem because the SCR system is heated. The truck can be started and driven normally.

1.INTRODUCTION AND SAFETY

1.16 Driving trucks with Euro IV/China IV (or equivalent) standard engines

OBD

The truck is equipped with an OBD (On-Board Diagnostics). MIL (Malfunction Indicator Lamp) symbol illuminates in the event of emission related errors. Stop the vehicle and check the reason for lamp illumination. Contact **UD Trucks** authorised dealer for assistance.

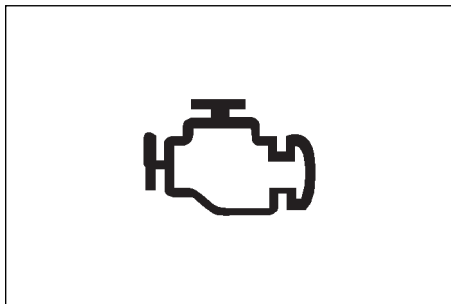

AdBlue level



Driving without Adblue in certain regions is a punishable offence. Do not drive without AdBlue or interfere with the exhaust cleaning system.

To check the amount of AdBlue in the tank, use the “Fuel Data” menu on the display and select “AdBlue”. It is an advantage to have this selected as a favorite menu, see the section Display. When amount of AdBlue reduces in the tank (approximately 10%), the information lamp will light and a message will be displayed to driver, top up with AdBlue.

If the tank for AdBlue is empty the following message is shown on the display, along with the information lamp and the MIL symbol. Fill the tank immediately with AdBlue.

Monitoring system for emission control

If a fault occurs in the NOx monitoring system then a message is shown on the display together with the yellow warning lamp (CHECK) and the MIL symbol. If the system detects that the fault persists then the engine's output is reduced by 40% of maximum output. Engine output returns to normal when the system detects that the fault has been rectified.

Dosing system for emission control

If a fault occurs in the NOx dosing system then a message is shown on the display together with the yellow warning lamp (CHECK).

1.17 Telematics gateway

Telematics gateway (if equipped) is an on-board unit used for data logging and communication between the vehicle and truck server. The telematics gateway will transfer the information to support the vehicle related services. To enable the communication to the truck server TGW services must be activated.

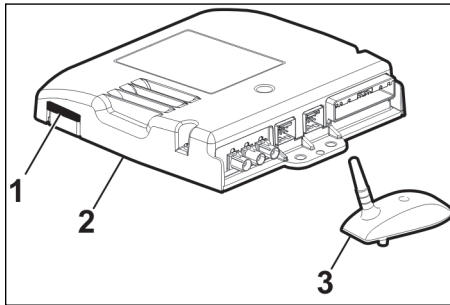

The system consists of:

1. Sim card
2. Telematics gateway unit
3. Antennas (GSM and GPS)

GSM-communication

Telematics gateway has an integrated GSM module for the data communication to and from the vehicle. The control unit has a slot for a SIM-card. The GSM antenna is placed on the truck roof (combined GSM/GPS-antenna).

NOTE

Do not place any metal objects over the antenna on the roof.

NOTE

Do not place any other transmitting antennas closer than 30 cm from the GPS/GSM-antenna.

GPS Satellite positioning

1. Antenna
2. Satellite
3. GPS connector
4. GSM connector
5. Telematics gateway unit

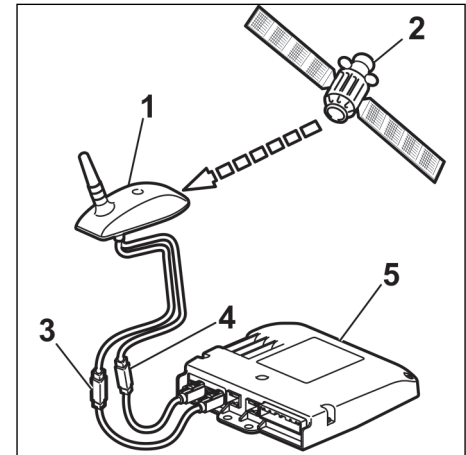

Telematics gateway can determine the geographic position of the vehicle through GPS-positioning. The GPS unit calculates the position with the help of signals from at least three satellites. The accuracy of calculation increases as the number of satellites the GPS unit is in contact with the vehicle's system. The GPS antenna is placed on the truck roof (combined GSM/GPS-antenna).

THIS PAGE HAS BEEN LEFT
BLANK INTENTIONALLY

2.GETTING IN AND OUT OF THE CAB

2.1 When getting into the cab

⚠ WARNING

- Ensure care when getting in and out of the cab, to avoid slip or fall.
- Maintain 3 point contact at all times with at least 2 feet and 1 hand or 2 hands and 1 foot firmly placed during all phases of getting in and out of the cab.

1. Open the door and hold the rear handle behind the door opening.

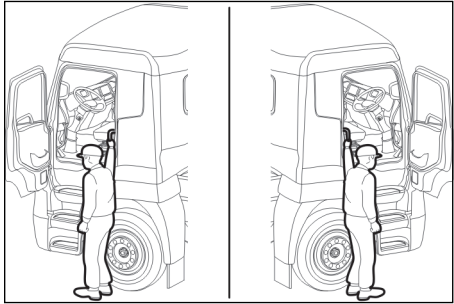

2. Hold the lower handles, climb the 1st step.

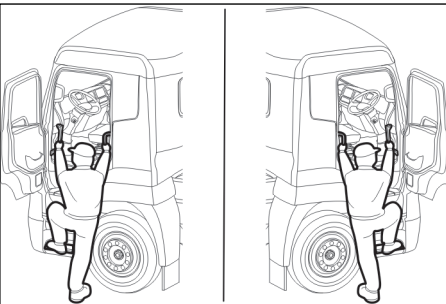

3. Place the second foot on the 2nd step.

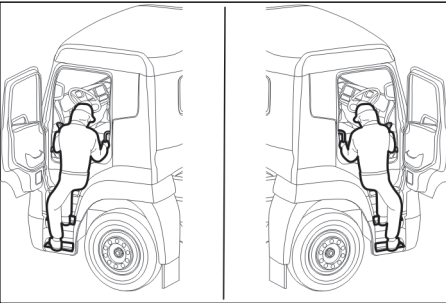

4. Hold upper handle climb the 3rd step.

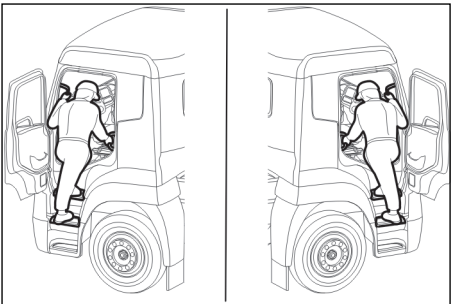

5. Step onto the cab floor with the second foot.

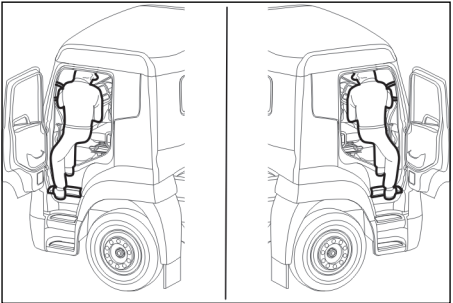

2.GETTING IN AND OUT OF THE CAB

6. Position comfortable in the driver's seat and release the grasp from the front upper handle.

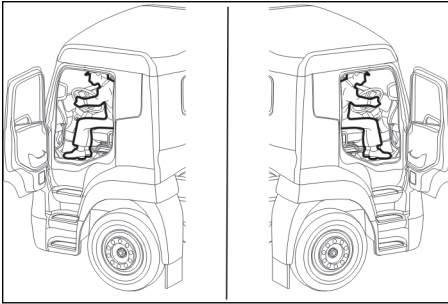

7. Close the door.

When getting out

When getting out, use the reverse process followed while getting in.

2.2 Doors

Opening and closing the doors

- When opening the door from outside, press the push button while pulling the door. When closing the door, hold the handle and push the door gently to close.

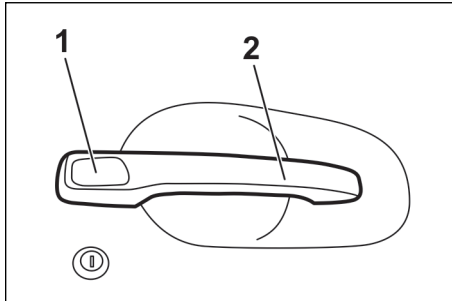

1. Push button
2. Handle

- When opening the door from the inside, pull the handle inner and push the door outwards. When closing the door, hold the handle and pull the door and close it gently. There is a lock knob (2) provided for locking the door.

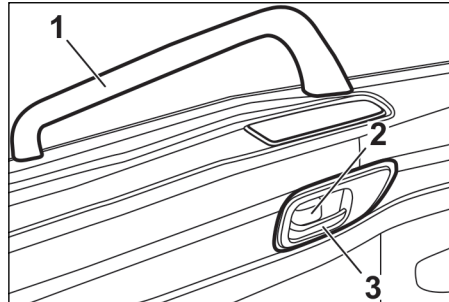

1. Handle
2. Lock knob
3. Handle inner

WARNING

Make sure that the doors are closed and locked before starting the vehicle to avoid accidental opening while driving.

CAUTION

Check both sides of the vehicle and ensure that the path of door opening is free from obstacle making it safe to open.

2.GETTING IN AND OUT OF THE CAB

Locking and unlocking door.

The door can be locked from inside by pushing the lock knob to lock position.

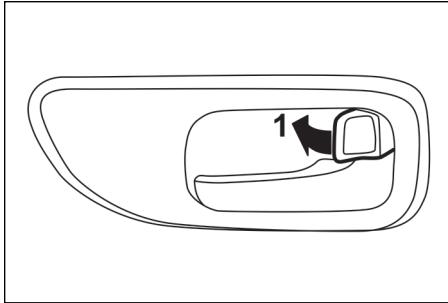

1. Lock position

Locking and unlocking door from outside

To unlock the door from the outside insert the key into the key hole and turn the key to unlock the door.

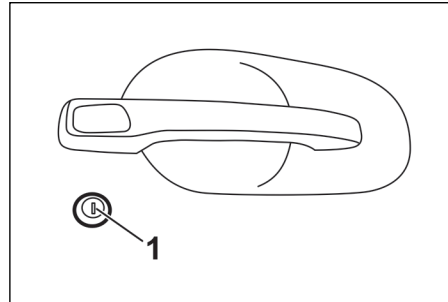

1. Key hole

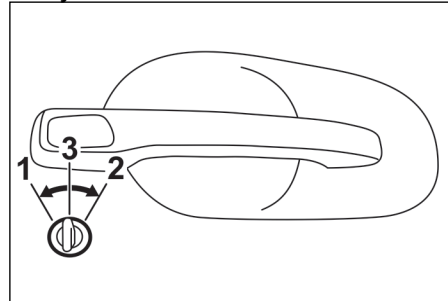

1. Lock position
2. Unlock position
3. Insertion position

Insert the ignition key and turn it towards the rear to lock the door and turning it towards the front will unlock the door. Return the key to the insertion position to remove it.

- The door can also be locked by pushing in the lock knob and then holding down the push button on door handle, while closing the door. When using this method to lock the door, be sure not to leave the ignition key in the cab.

NOTE

Do not to leave the keys inside vehicle when locking the door from outside.

2.3 Seats

Driver's seat

DANGER

Do not adjust the seat while driving.

NOTE

Adjust the driver's seat to a position where all the switches and pedals can be operated easily. After completing the adjustments, make sure that it is firmly locked in place.

Mechanical suspension driver seat

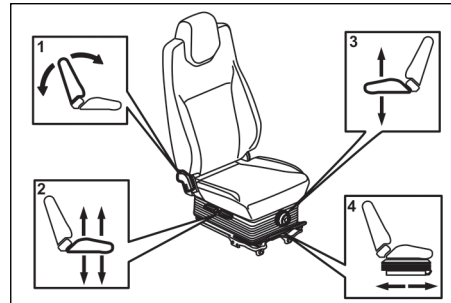

- 1: Backrest adjustment
- 2: Seat tilt and height adjustment
- 3: Suspension height adjustment
- 4: Longitudinal seat adjustment

Backrest adjustment

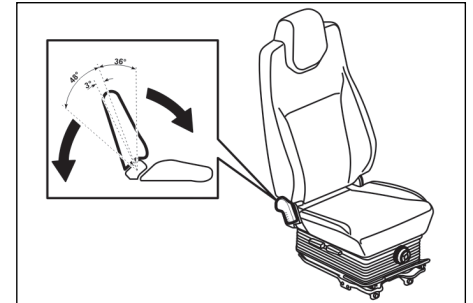

When the backrest recliner handle is rotated upwards, it unlocks the recliner and allows the user to adjust the backrest's position. During the adjustment, the handle must be held in the lifted position and once the desired backrest position is achieved, the handle must be released to lock the backrest. The backrest locks in steps of 3°.

The locking range is 36° from vertical to forward and 48° from vertical to rearward / backward.

2.GETTING IN AND OUT OF THE CAB

Seat tilt and height adjustment

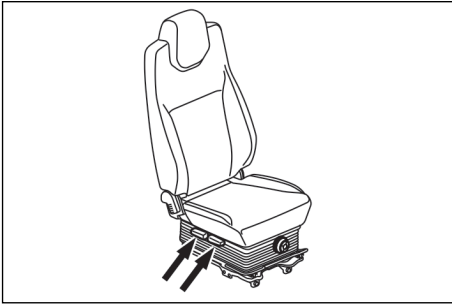

When the front handle is lifted upwards, the seat cushion can be raised or lowered. When a desired position is reached, release the handle to lock the cushion in place. Five locking positions are possible over 60 mm of total lift.

When the rear handle is lifted upwards, the back of the seat cushion can be raised or lowered. When a desired position is reached, release the handle for cushion to lock in place. Five locking positions are possible over 60 mm of total lift.

Suspension height adjustment

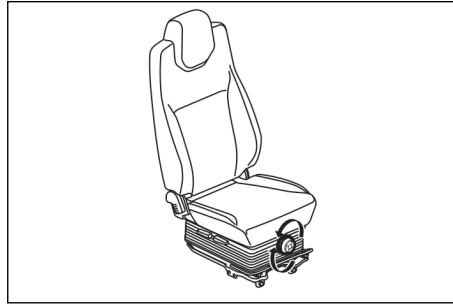

When the height adjuster is turned clockwise, it stiffens the mechanical spring and when it is turned counterclockwise, it softens the mechanical spring.

This allows the user to adjust the stiffness of the mechanical suspension for comfort. It also lets the user to raise or lower the suspension for height adjustment. The suspension can be adjusted for a range of 50 kg to 120 kg of operator's weight.

Longitudinal seat adjustment

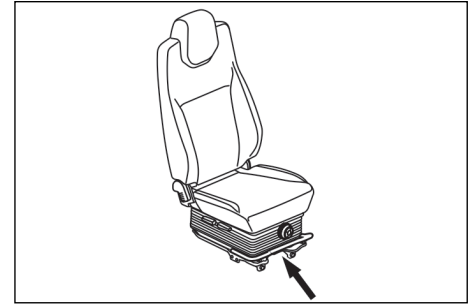

When the slide rail handle is pulled upwards the tracks are unlocked, allowing the seat to be moved forwards and backwards. Once a desired position is achieved, release the handle to lock the seat in place. The sliding position can be adjusted over 13 steps of 10 mm each, allowing a total longitudinal adjustment of 130 mm.

2.GETTING IN AND OUT OF THE CAB

Air suspension driver seat

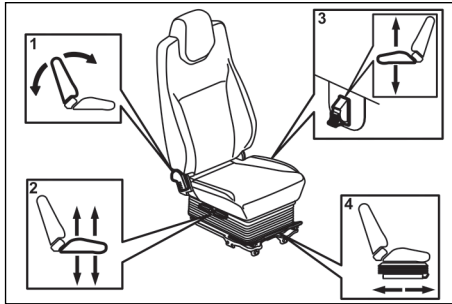

- 1: Backrest adjustment
- 2: Seat tilt and height adjustment
- 3: Suspension height adjustment
- 4: Longitudinal seat adjustment

Backrest adjustment

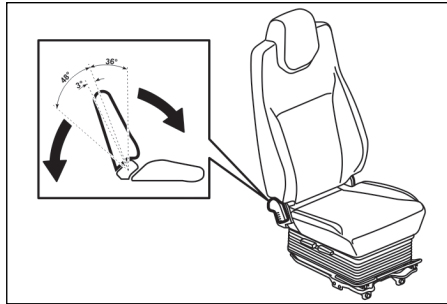

When the backrest recliner handle is rotated upwards, it unlocks the recliner and allows the user to adjust the backrest position. During the adjustment the handle must be held in the lifted state and once the desired backrest position is achieved the handle must be released to lock the backrest. The backrest locks in steps of 3°.

The locking range is 36° from vertical to forward and 48° from vertical to rearward / backward.

Seat tilt and height adjustment

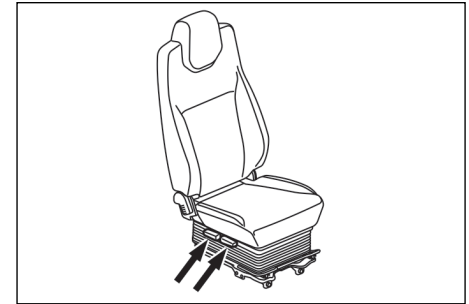

When the front handle is lifted upwards, the front of the seat cushion can be raised or lowered. When a desired position is reached, release the handle for cushion to lock in place. Five locking positions are possible over 60 mm of total lift.

When the rear handle is lifted upwards, the back of the seat cushion can be raised or lowered. When a desired position is reached, release the handle for cushion to lock in place. Five locking positions are possible over 60 mm of total lift.

2.GETTING IN AND OUT OF THE CAB

Suspension height adjustment

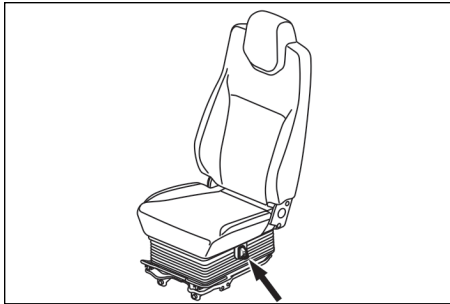

When the height adjuster is lifted upwards it inflates the air spring and when it is pushed downwards it deflates the air spring.

This allows the user to adjust the amount of stiffness of air suspension for comfort. It also lets the user to raise or lower the suspension for height adjustment. The suspension can be adjusted up to a 100mm of maximum height possible.

Longitudinal seat adjustment

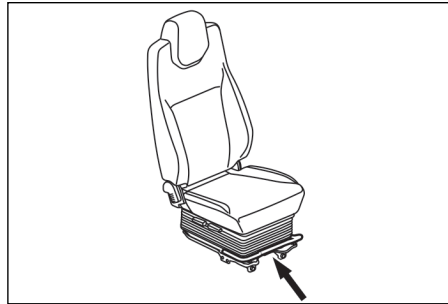

When the slide rail handle is pulled upwards the tracks are unlocked, allowing the seat to be moved forwards and backwards. Once the desired position is achieved, release the handle to lock the seat place. The sliding position can be adjusted over 13 steps of 10 mm each, allowing a total longitudinal adjustment of 130 mm.

2.GETTING IN AND OUT OF THE CAB

Passenger seat

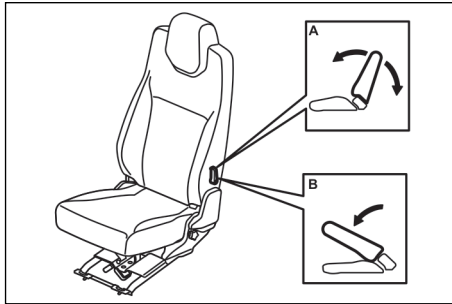

- 1: Backrest adjustment
- 2: Backrest full fold down

Backrest adjustment

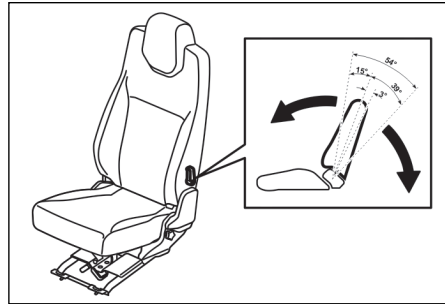

When the backrest recliner handle is pulled upwards, it unlocks the recliner and allows the user to adjust the backrest position. During the adjustment the handle must be held in the lifted state and once the desired backrest position is achieved the handle must be released to lock the backrest. The backrest locks in steps of 3°. The locking range is 54° from vertical to backwards. The locking range is 15° from vertical to forward and 39° from vertical to rearward / backward.

Full fold down adjustment

CAUTION

Do not sit or stand on the passenger seat in folded condition.

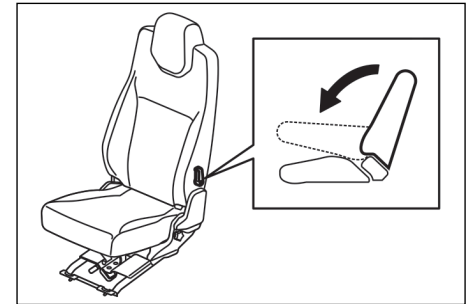

Pull up the recliner handle to unlock and adjust the backrest position. In unlocked condition the backrest can be folded fully. The backrest can be back to upright position by pushing handle down to release unlock and simply lifting the backrest upwards until a locking sound is heard.

2.GETTING IN AND OUT OF THE CAB

Centre seat - If equipped

 **DANGER**

Center seat should not be used
when vehicle is moving.

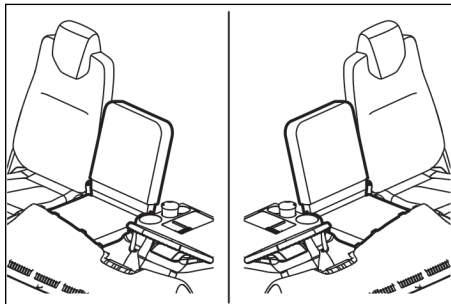

Center seating position designated
for use only when the vehicle is
stationary.

2.4 Seat belts

WARNING

- Always wear the seat belt for safety during travelling.
- Do not adjust the seat belt while driving, adjusting seat belt while driving can cause distraction, leading to accident.

Driver's seat and passenger seats

- Make sure that there is no twisting of the belt while inserting the tongue into the buckle until it locks in place. The level of safety provided by the seat belt will decrease if the belt is twisted.
- To release the seat belt, press the red button on the end of the buckle. The belt will automatically wind up, always hold the tongue while returning the belt to its retracted position.

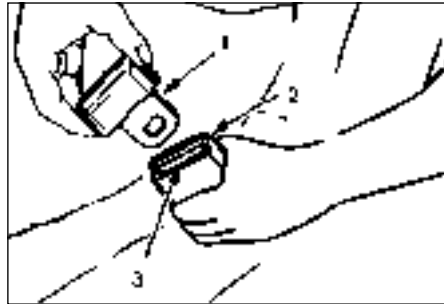

1. Tongue
2. Buckle
3. Button

Three-point seat belt with ELR (Emergency Lock Roll device)

NOTE

- **Seat belt with ELR can be freely extended and contracted, it automatically locks when the belt is pulled rapidly. Pull the belt out slowly.**
- **Replace the seat belt if it is damaged or found defective at UD Trucks authorised dealer.**

Precautions for wearing seat belts

If the driver tries to drive without wearing the seat belt, the warning light will illuminate to warn the driver. when the ignition key is turned to **ON** or **START**.

Seat belt warning light

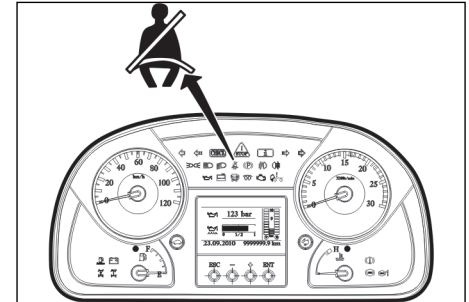

With seat belt reminder feature the icon will be illuminated with sound when driver has not fasten seat belt.

2.GETTING IN AND OUT OF THE CAB

2.5 Steering wheel adjust

Adjustment method

⚠ DANGER

Do not adjust the steering wheel while driving it could lead to accident.

1. Adjust the seat position before adjusting steering wheel position.
2. Pull the lock lever forward to release the lock.

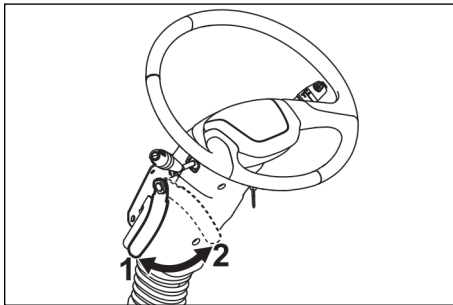

1. Steering wheel lock position
2. Steering wheel unlock position

3. The telescopic adjustment allows the steering wheel to be moved up or down.

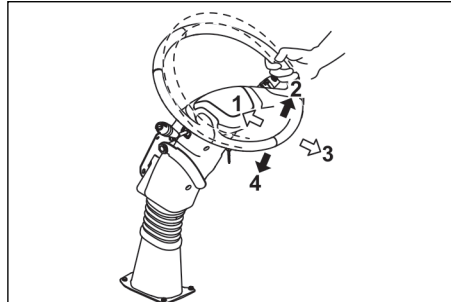

1. Forward
2. Up
3. Backward
4. Down

4. The tilt adjustment allows the steering wheel to be moved forward or backward.
5. After the steering wheel has been moved to a comfortable position, push the lock lever to lock position.
6. Ensure the steering wheel is locked securely in its position.

3. EQUIPMENT DESCRIPTION AND OPERATION

3.1 Instrumentation

Instrument panel and controls

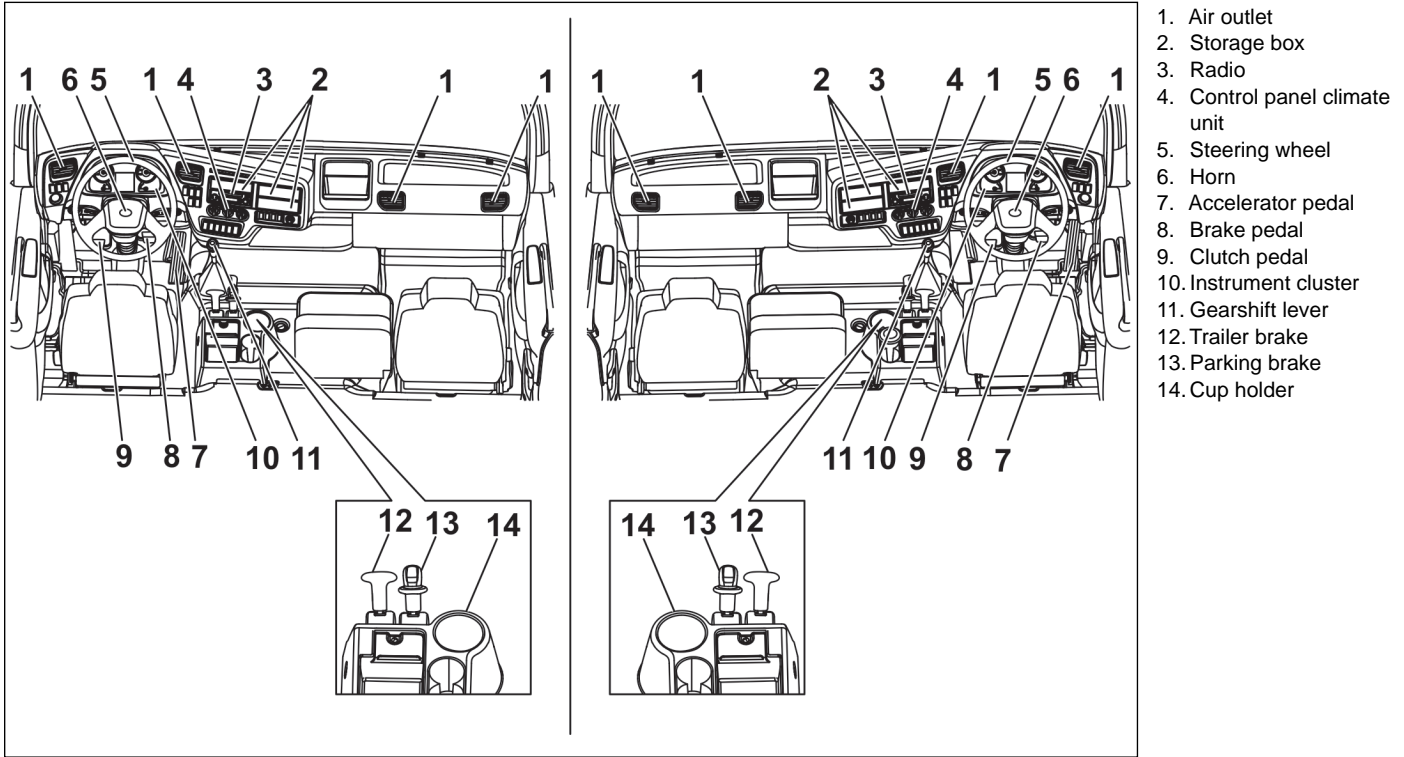

3. EQUIPMENT DESCRIPTION AND OPERATION

Instrument cluster (IC)

The IC provides information to the user by using gauges, telltale lamps and a display.

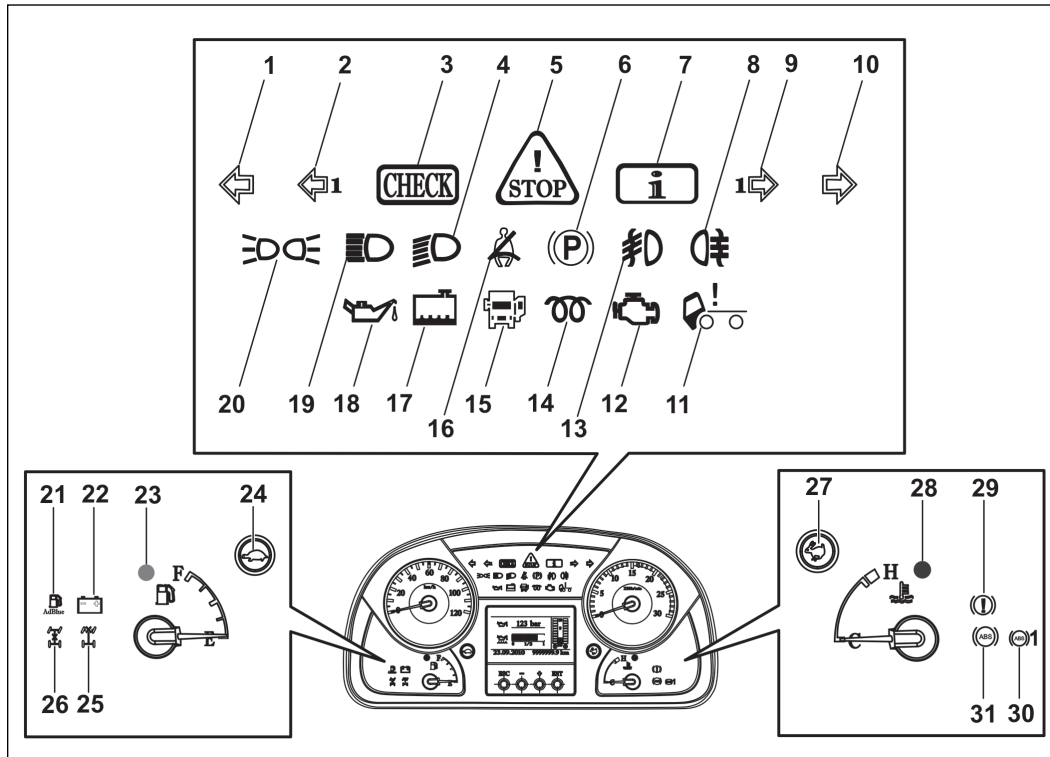

1. Left turn indicator - tractor/rigid
2. Left turn indicator trailer
3. Check - Medium severity
4. Dipped beam
5. Stop - High severity
6. Parking brake applied
7. Info - Low severity
8. Rear Fog lamp
9. Right turn indicator - trailer
10. Right turn indicator - tractor/rigid
11. Cab tilt
12. Engine fault
13. Fog lamp - front
14. Engine pre-heat
15. Door open
16. Seat belt reminder
17. Coolant level low
18. Engine oil pressure low
19. High beam
20. Front and rear position lamp
21. AdBlue level low
22. Battery not charging
23. Fuel level low- yellow indicator
24. Gearshift lever- low range
25. Differential lock interaxle and wheels
26. Differential lock interaxle
27. Gearshift lever - high range
28. Coolant temperature high
29. Brake pressure low
30. ABS fault on trailer
31. ABS fault on tractor/rigid

3. EQUIPMENT DESCRIPTION AND OPERATION

Instrument gauge

The following gauges are included in the instrument.

- Tachometer
- Speedometer
- Coolant temperature gauge
- Fuel level gauge

Tachometer

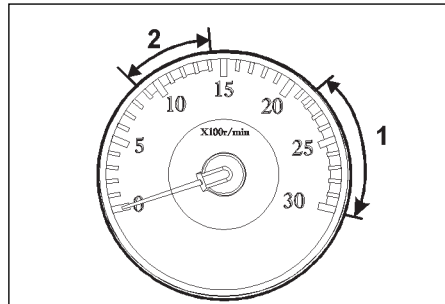
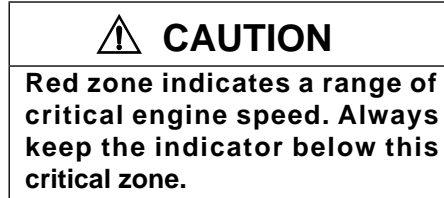

1. Red zone (2150 - 3000 RPM)

2. Green zone (900 - 1400 RPM)

The tachometer shows the engine speed in revolutions per minute. The green zone indicates economic driving.

Always keep the indicator within the green zone.

Speedometer

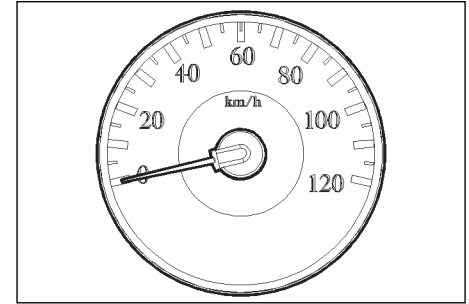

The speedometer shows the vehicle's speed. Range of speedometer gauge is from 0 – 120 km/h.

3. EQUIPMENT DESCRIPTION AND OPERATION

Coolant temperature gauge

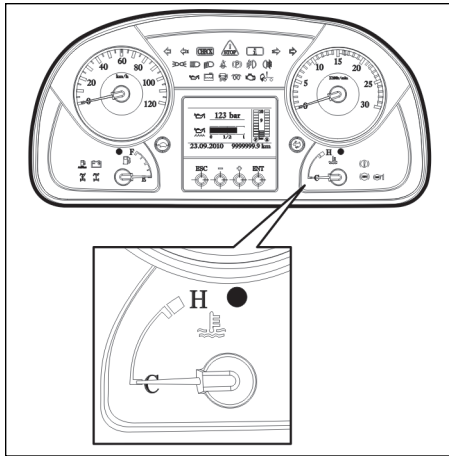

The purpose of the engine coolant temperature gauge is to display the engine coolant temperature. Engine coolant temperature gauge has a warning lamp indicator (Placed on right side, where it is marked as **H**) associated with it which is activated when the coolant temperature is high.

Fuel level gauge

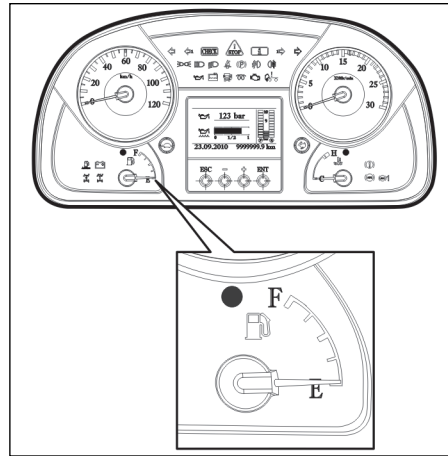











The gauge shows the approximate amount of fuel in the tank. The meter functions when the starter key is in the driving position. When the fuel level becomes lower than a predefined value, the low fuel telltale indicator illuminates.













3. EQUIPMENT DESCRIPTION AND OPERATION

3.2 Indicators









The following telltale indicators are found in the instrument cluster

SI No.	Telltale Indicator	Description	SI No.	Telltale Indicator	Description
1		Left turn light indicator - Tractor/Rigid (Green)	6		Parking brake applied (Red)
2		Left turn light indicator - Trailer (Green)	7		INFO - Low severity (White)
3		CHECK: Medium severity {The diagnostic lamps are used with warning messages to indicate the severity of the message.} (Yellow)	8		Fog lamp rear (Yellow)
4		Dipped beam: Dipped beam indicator will be used to indicate the activation of dipped beams to the driver. (Green)	9		Right turn light indicator - Trailer (Green)
5		STOP: High severity {The diagnostic lamps are used with warning messages to indicate the severity of the message.} (Red)	10		Right turn light indicator - Tractor/Rigid (Green)

3. EQUIPMENT DESCRIPTION AND OPERATION

SI No.	Telltale Indicator	Description	SI No.	Telltale Indicator	Description
11		Cab tilt (Red)	17		Engine coolant level low (Red)
12		Engine fault (Yellow)	18		Engine oil pressure low (Red)
13		Fog lamp front (Green)	19		High beam (Blue)
14		Engine pre-heat (Yellow)	20		Front and rear position lamp (Green)
15		Door open (Yellow)	21		AdBlue level low (Blue)
16		Seat belt reminder (Red)	22		Battery not charging (Red)

3. EQUIPMENT DESCRIPTION AND OPERATION

SI No.	Telltale Indicator	Description	SI No.	Telltale Indicator	Description
23		Fuel level low (Yellow)	28		Engine coolant temperature high (Red)
24		Gear shift lever in low range (Green)	29		Brake air pressure high/low (Red)
25		Differential lock between wheels engaged (Red)	30		ABS fault on Trailer (Yellow)
26		Differential lock between axles engaged (Red)	31		ABS fault on Tractor/Rigid (Yellow)
27		Gear shift lever in high range (Green) Note: Indicator will not illuminate, only buzzer will sound			

3. EQUIPMENT DESCRIPTION AND OPERATION

Instrument, display

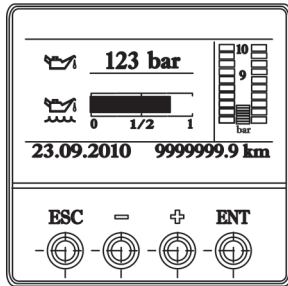

The display is located in the middle of the instrument cluster. Display can be used to see vehicle messages, control certain functions on the truck and see information about the truck, amongst them temperatures, levels and distances.

The layout of the display

If something occurs which demands the driver's attention, a vehicle message is shown in the display. The display can show three types of messages: Information is indicated by a white lamp, warning is indicated by a yellow lamp, stop is indicated by a red lamp.

The messages shown while driving that requires an immediate action are shown automatically with an accompanying symbol. If red lamp lights while the engine is running, an alarm signal is also activated. Several messages can be active at the same time. When a new message is activated, the new message is shown instead of the old one if the new one has the same or higher priority.

If the vehicle message is displayed user has to acknowledge by pressing "ESCAPE" button.

Control and warning lamps

The instrument has warning lamps and control lamps, to indicate status and warnings. In the above display there are three lamps, a white information lamp (**i**), a yellow warning lamp (**CHECK**) and a red stop lamp (**STOP**) which illuminates with other telltale indicator or together with a message in the display. The indicator that illuminates depends on how serious the fault is. In addition the driver will be alerted with a buzzer sound when the following indicators illuminate. Hazard indicator, direction indicator, engine overrun warning; downhill RSL, park brake, PTO, door open, seat belt, and stop.

Menu selection

For safety reason the number of accessible menus are less when driving, than when the vehicle is stationary.

3.3 Display menu

Display control interaction

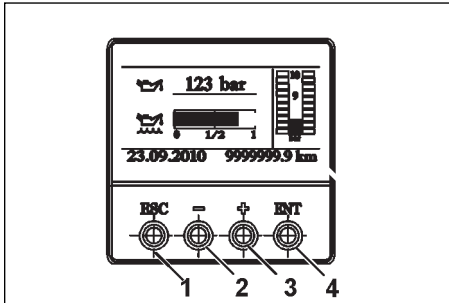

The display menu is controlled by two sorts of events.

Driver action events: The user can control the display with the push buttons listed below.

- Escape button (1)
- Down button (2)
- Up button (3)
- Enter/OK button (4)

Software events: Internally generated events in the instrument cluster, for example fault message events and timers.

3. EQUIPMENT DESCRIPTION AND OPERATION

Driving menu

The driving menu has the following choices in the following order.

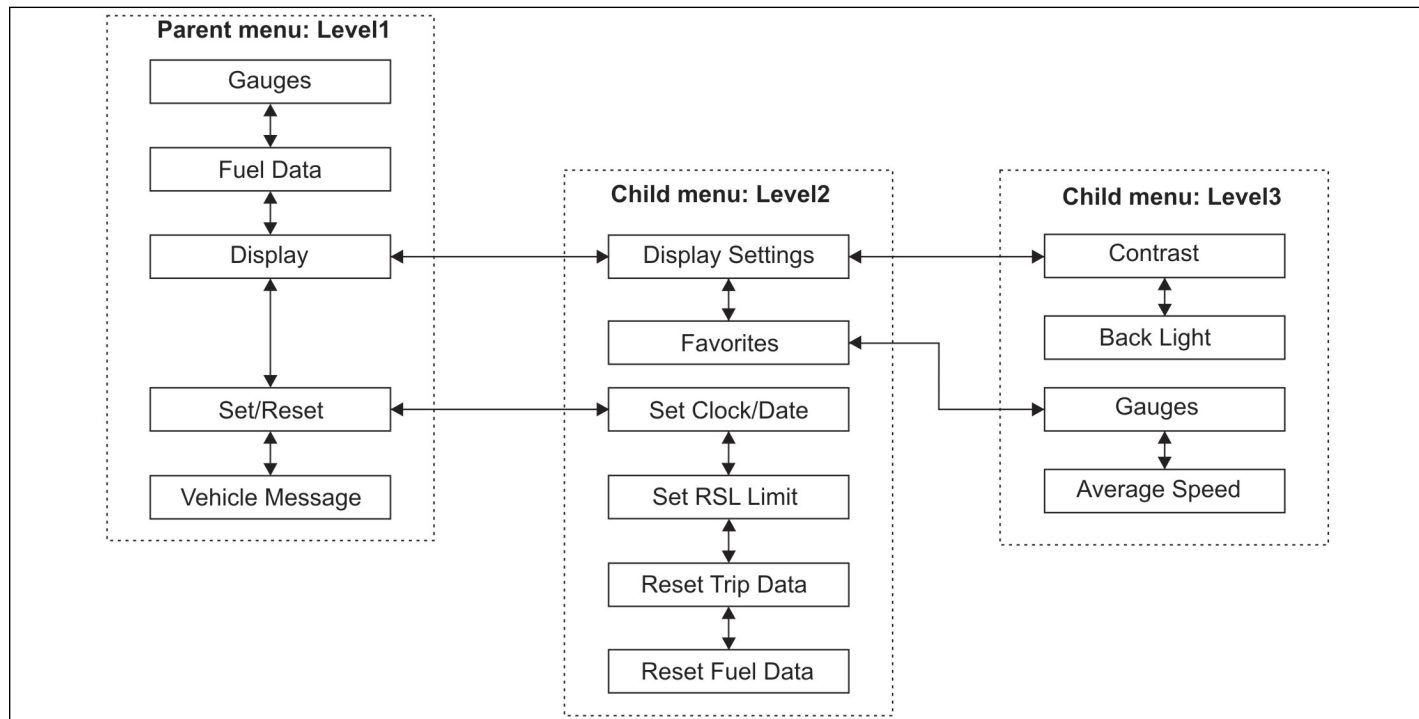

Note: The above diagram describes the different menus.

Full menu or non-driving menu

3. EQUIPMENT DESCRIPTION AND OPERATION

When the vehicle is stationary the full or non-driving menu can be accessed.

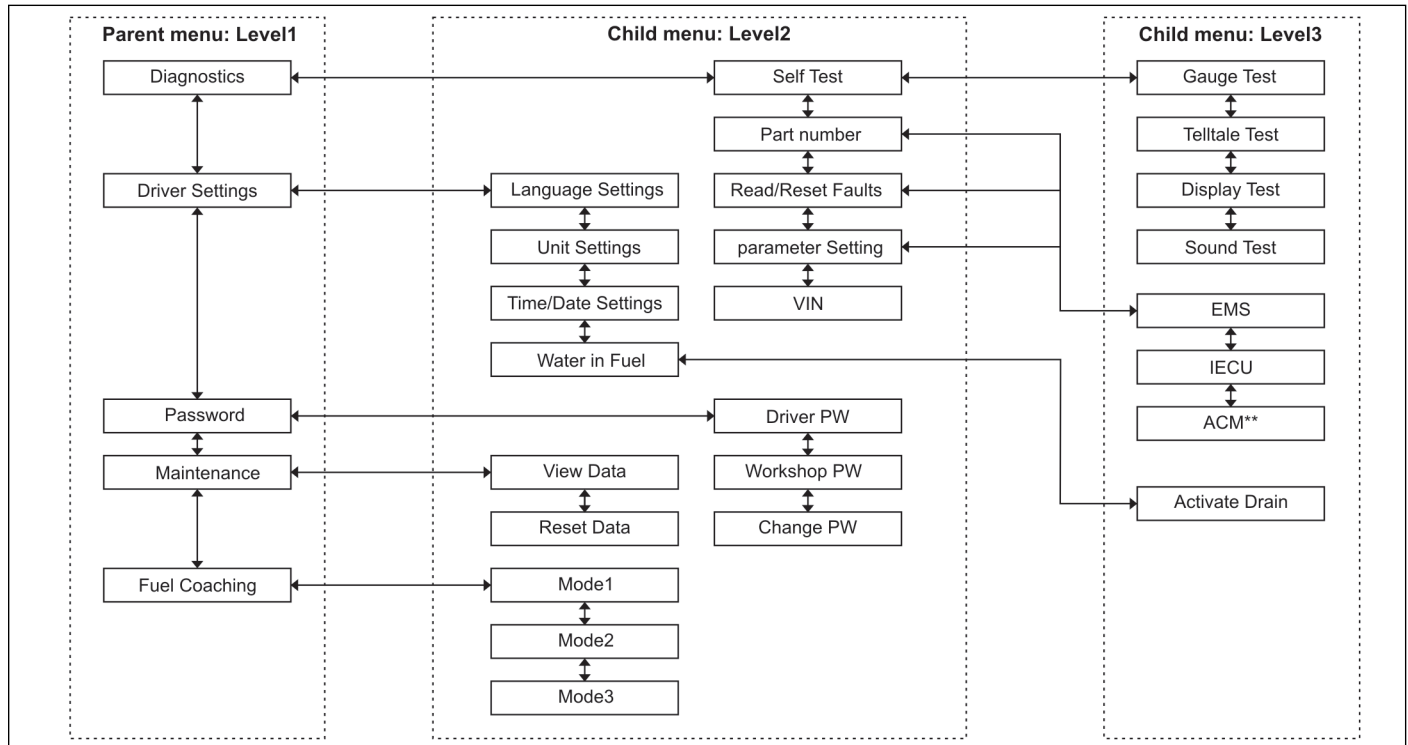

Note: The above diagram describes the different menus.

The ** in the figure above indicates that this shall be visible when set by EOL parameters.

3. EQUIPMENT DESCRIPTION AND OPERATION

Driving Menu			
1	Gauges	Adblue gauge	It shall display only the gauges with menu counter, It shall not display which gauge it is. For E.g. Gauge (1)
		Outdoor temperature	
		Engine Oil Pressure	
		Engine Oil Level	
		Engine Hours	
2	Fuel data	Average fuel	It shall display only the gauges with menu counter, It shall not display which gauge it is. For E.g. Fuel Data (1)
		Leg Fuel*	
		DTE (Distance to empty)	* Leg Fuel: The leg fuel/trip fuel is the fuel consumption.
		Inst fuel**	** Inst Fuel: Instantaneous fuel consumption
3	Display	Display Settings	Contrast
			Back light
		Favorites	Gauges
			Average speed
4	Set/Reset	Set Clock/Date	
		Set RSL Limit (after entering password)	
		Reset trip data (after entering password)	
		Reset Fuel Data	
5	Vehicle Message	The display can show three types of messages: Information is indicated by a white lamp, warning is indicated by a yellow lamp, stop is indicated by a red lamp.	

3. EQUIPMENT DESCRIPTION AND OPERATION

Below mentioned is the full menu or non-driving menu structure which also include driving menu.

Full menu or Non-driving menu			
6	Diagnostics	Self-test	Telltale Indicator test
			Gauge test
			Display test
			Sound test
		Part Number	EMS
			IECU
			ACM
		Parameter setting	EMS
			IECU
			ACM
		Read Fault/Clear Faults	EMS
			IECU
			ACM
		VIN	
7	Driver settings	Language	
		Unit	
		Time/Date	
		Water in fuel	Activate drain

3. EQUIPMENT DESCRIPTION AND OPERATION

Full menu or Non-driving menu			
8	Password	Workshop PW	
		Driver PW	
		Change PW (after entering password)	Workshop: ENTER OLD PASSWORD ENTER NEW PASSWORD
			Driver: ENTER OLD PASSWORD ENTER NEW PASSWORD Note: Default password for user is 1234, user can change the password after.
9	Maintenance	View data	
		Reset data	
10	Fuel coaching	Mode1	
		Mode2	
		Mode3	

3. EQUIPMENT DESCRIPTION AND OPERATION

3.4 Switches

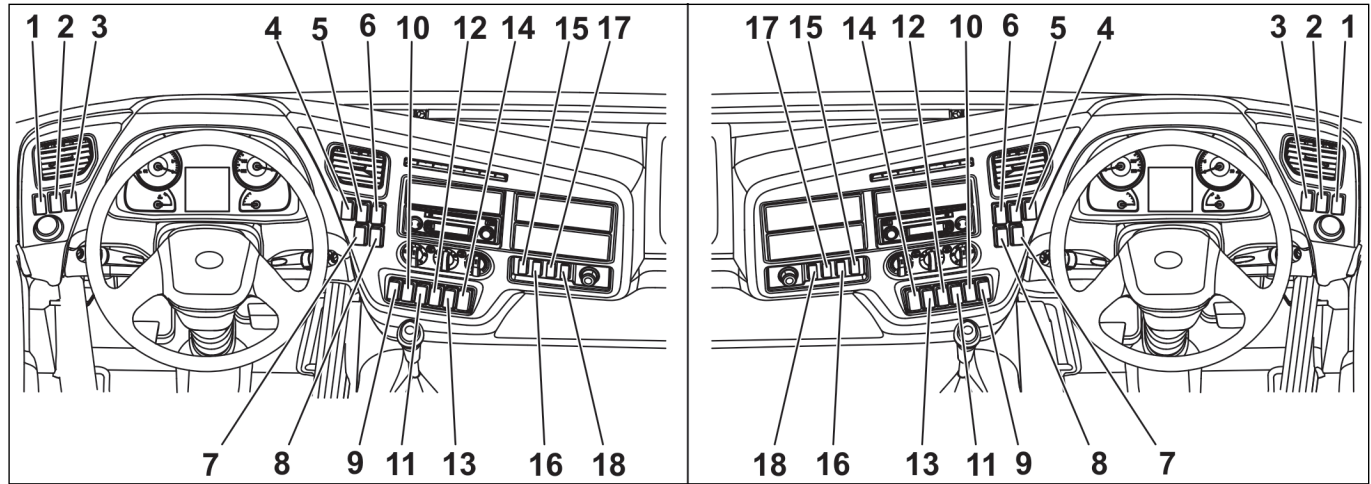

Switch position	Description	Switch position	Description
1	DRIVER ID for TGW	10	Beacon light
2	Horn selector	11	Interior light (Only for high roof cab)
3	Head lamp leveller	12	Front fog lamp
4	Engine PTO	13	Rear fog lamp
5	Transmission PTO	14	Switch cover
6	ADR	15	Bodybuilder - 1
7	Differential lock (Interaxles) Differential lock (Interaxles and Rear wheels)	16	Bodybuilder - 2
8	Bogie lift / Bogie press	17	Bodybuilder - 3
9	Working lamp	18	Switch cover

The availability and position of switches vary according to the equipment installed in the vehicle.

3. EQUIPMENT DESCRIPTION AND OPERATION

1. Driver ID for TGW - if equipped

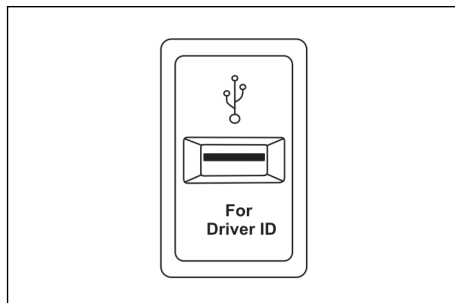

2. Horn selector

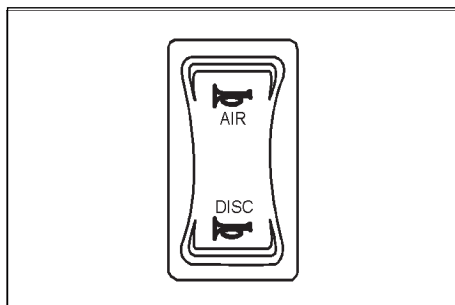

3. Head lamp leveller switch

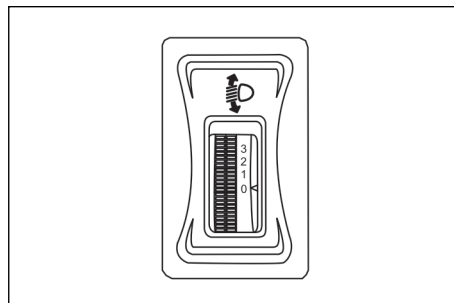

Head lamp leveling is done by rotating the switch knob based on the load conditions. Position the switch in "0" when the vehicle is in unladen condition and adjust to other positions gradually for better visibility of head lamp.

4. Engine PTO

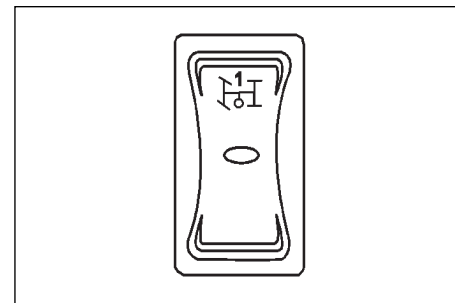

5. Transmission PTO

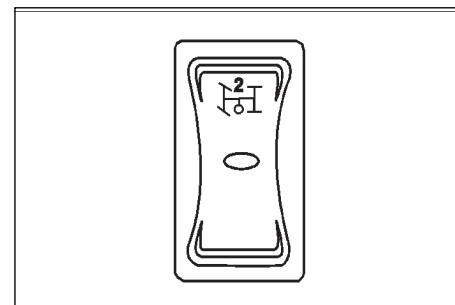

3. EQUIPMENT DESCRIPTION AND OPERATION

6. ADR Switch - if equipped

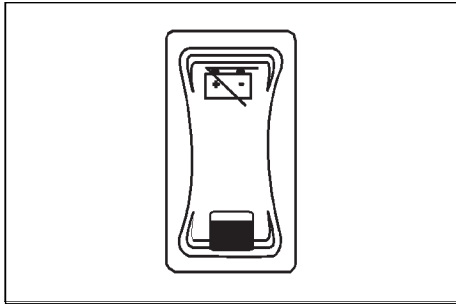

7. Diff lock Interaxles and rear wheel

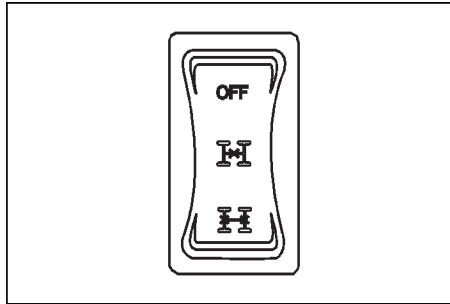

9. Working lamp

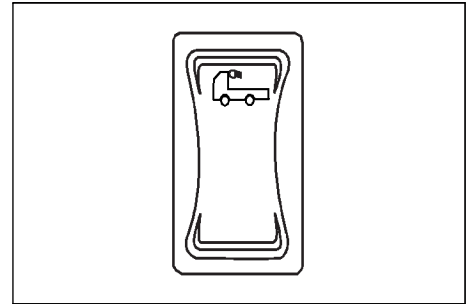

7. Diff lock Interaxles switch

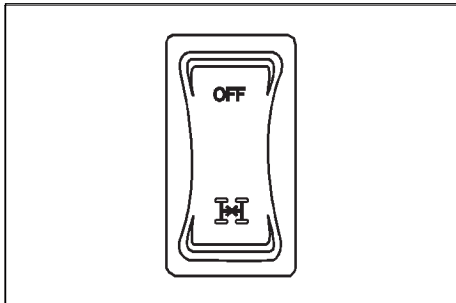

8. Bogie lift/Bogie press switch

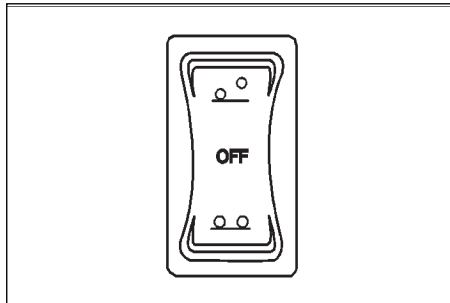

10. Beacon light switch - if equipped

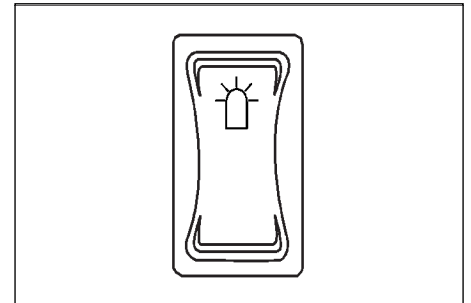

3. EQUIPMENT DESCRIPTION AND OPERATION

11. Interior Light Switch

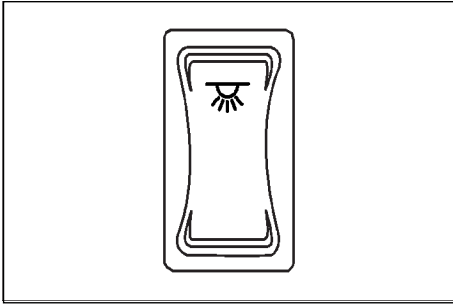

13. Rear fog lamp

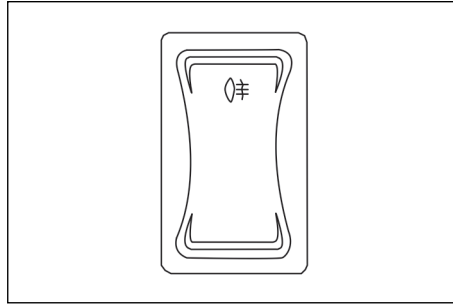

15. 16. 17. Bodybuilder switch

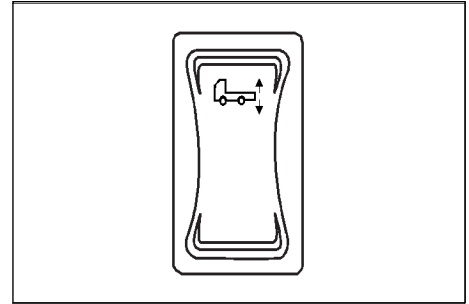

12. Front fog lamp

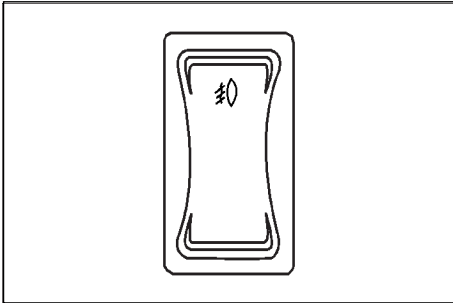

14. and 18 Switch cover

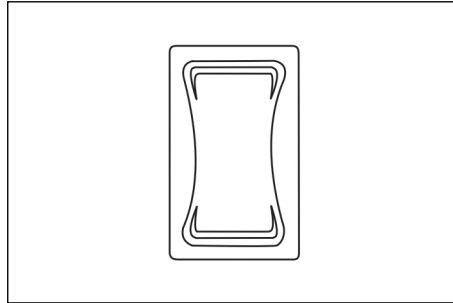

3. EQUIPMENT DESCRIPTION AND OPERATION

Mirror heating switch - if equipped

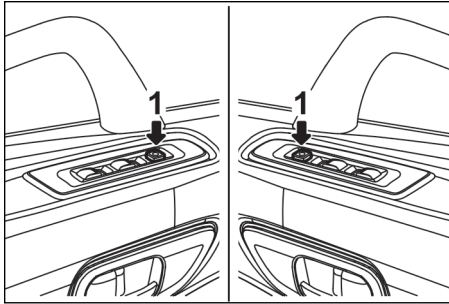

NOTE

To activate mirror heating function, press the button for less than 2 sec, this will function for a little time. At lower temperatures, if fog or snow is too high, driver or user can press the button for more than 2 sec to keep the mirror heating function active for longer time (approximate 1 hour).

The exterior rear view mirror heater is used to remove/ melt the frost on the rear view mirrors during cold/ snowy condition. Mirror heating push button is provided on the driver side window door control panel.

NOTE

Always ensure that engine is in running condition before activating mirror heating function.

3. EQUIPMENT DESCRIPTION AND OPERATION

Fuse and relays

Fuse and relay centre decal is placed inside the dashboard on passenger side of the cab

<u>FUSES AND RELAY DETAILS</u>						
<u>Relays</u>		<u>Fuses</u>				
K01	Brake Lamp	01	15A	Instrument Cluster Supply	41	Free
K02	Free	02	10A	Water in fuel	42	10A Front Fog Lamp
K03	Beacon Lamp	03	25A	ABS ECU power supply	43	5A Low range Inhibitor Valve
K04	Front Fog Lamp	04	5A	Interior Light(LH&RH)	44	5A Gear Box SW
K05	Rear Fog Lamp	05	10A	Brake and reverse Lamp	45	10A Washer
K06	Mirror Heating	06	5A	Air Dryer	46	Free
K07	Trailer Position Lamp	07	5A	Beacon Lamp	47	Free
K08	Illuminate light Position	08	5A	Audio	48	Free
K09	H/L Main Beam LH&RH	09	10A	Rear Fog Lamp	49	5A Trailer Direction Indicator RH
K10	H/L Dipped Beam LH&RH	10	10A	Mirror Heating (LH &RH)	50	5A Trailer Rear Fog Lamp
K11	Air Dryer	11	20A	HVAC Power	51	5A Trailer Brake Lamp
K12	5th Wheel Working lamp	12	5A	Stalk Switch-H/L	52	5A Trailer Position Lamp LH&RH
K13	Wind Screen Wiper	13	15A	Flasher Supply	53	5A Trailer Reverse Lamp
K14	Horn	14	10A	H/L Main & dipped Beam	54	5A H/L Position Lamp LH
K15	Reverse lamp And Buzzer	15	5A	Interior Roof Lamp	55	5A H/L Position Lamp RH
K16	HVAC System	16		Free	56	10A Illumination Time
K17	Free	17		Free	57	5A H/L Main Beam LH
K18	ADR Alternator Shut Off	18	15A	Trailer ABS supply	58	5A H/L Main Beam RH
K19	Free	19	5A	Ignition Switch	59	5A H/L Dipped Beam RH
K20	Washer motor	20	10A	Position Lamp	60	5A H/L Dipped Beam RH
K21	Wiper Low	21	5A	Power Outlet,24V	61	Free
K22	Wiper High	22	5A	Audio(KI.R)	62	10A AVU Value
K23	HVAC Power	23	5A	5th Wheel Working Lamp	63	5A Tachograph
K24	Power Relay(EMS)	24	10A	Power window-Driver Side	64	Free
K25	Alternator Controlled Relay	25	10A	Power window-Co Driver side	65	5A Pre-heater Relay
K26	Free	26	5A	Bogie lift	66	10A IECU Supply
K27	Free	27		free	67	5A H/L Leaving motor
K28	Free	28		free	68	Free
K29	Radio Line Bus Bar (KI.R)	29	5A	Trailer ABS(KI.15)	69	Free
K30	Ignition line Bus Bar (KI.15)	30	15A	Wind screen wiper	70	Free
K31	Free	31	5A	Horn	71	5A ADR Alternator Shut off Relay
K48	Pre Heater Relay	32		Free	72	5A Mirror Heater
		33	10A	Diff lock & PTO	73	5A Air Dryer Relay
		34	5A	Stalk Switch-H/L(KI.15)	74	5A Trailer Direction Indicator
		35	5A	ABS supply(KI.15)	75	Free
		36	5A	Free	76	30A K24 Power
		37	5A	HVAC supply(KI.15)	77	Relay
		38	5A	SCR	78	Free
		39		Free	79	Free
		40	5A	Alternator	80	Free

3. EQUIPMENT DESCRIPTION AND OPERATION

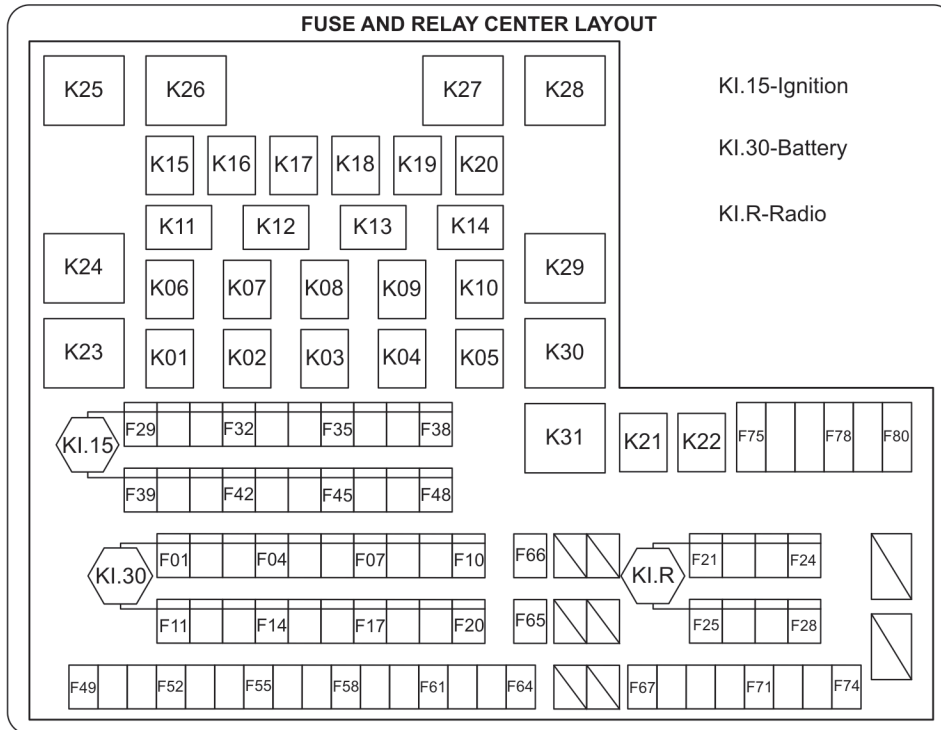

3. EQUIPMENT DESCRIPTION AND OPERATION

3.5 Combination switch

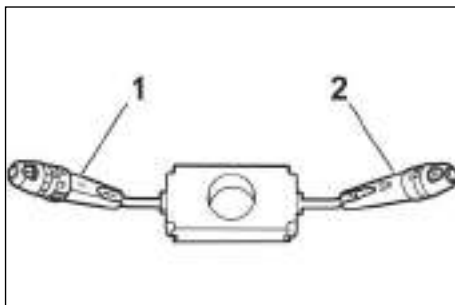

- 1. Left side control
- 2. Right side control

Left side control	Right side control
Light control	Auxiliary brake
Flash to pass	Washer/Wiper
Direction indicator	Hazard indicator
Cruise control	

Following are 4 types of combination switch.

With cruise control and auxiliary brake 2 position

With cruise control and auxiliary brake 3 position

Without cruise control and auxiliary brake 2 position

Without cruise control and auxiliary brake 3 position

Auxiliary brake

To activate auxiliary brake the combination switch is pushed in downward direction.

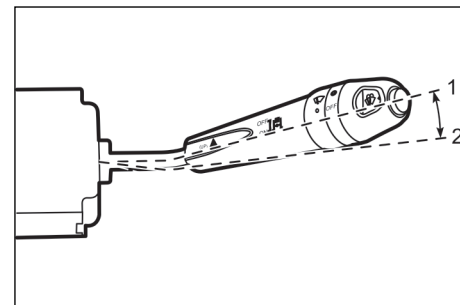

Auxiliary brake with two positions - if equipped with EPG

Auxiliary brake	Switch position
OFF	1
ON	2 and 3

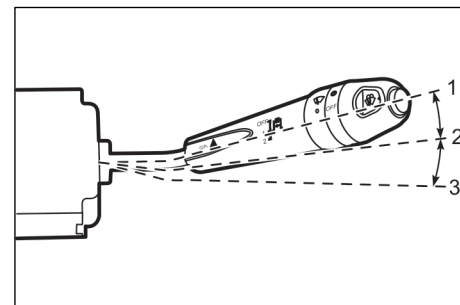

Auxiliary brake with three positions - if equipped with UD EEB

3. EQUIPMENT DESCRIPTION AND OPERATION

Washer function

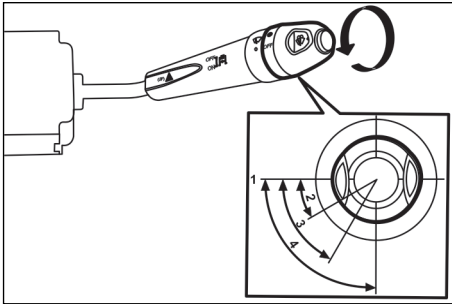

1. OFF
2. Intermittent
3. Low speed
4. High speed

Wiper function: Wiper speed can be controlled by rotating the ring on the combination switch to any one of the following 4 steady positions.

Wiper momentary active

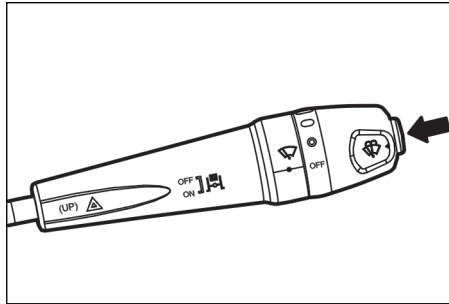

Washer can be controlled through the push button at the end of the combination switch, it includes 1 rest position and 1 momentary active position.

Hazard indicator

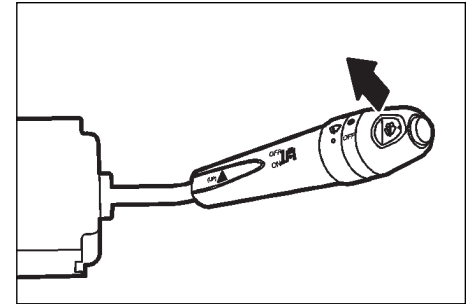

To activate hazard indicator the combination switch is pulled in upward direction towards the steering wheel from the neutral position.

3. EQUIPMENT DESCRIPTION AND OPERATION

Light control

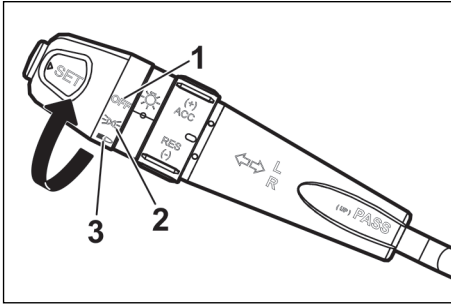

Light switch	Combination switch position
OFF	1
Parking light	2
Low	3
High beam	3 and press down

The light function (OFF, parking light, head lamp) shall be controlled through a rotating ring. Dipped/high beam change will be controlled by moving the combination switch towards the steering wheel.

Flash to pass

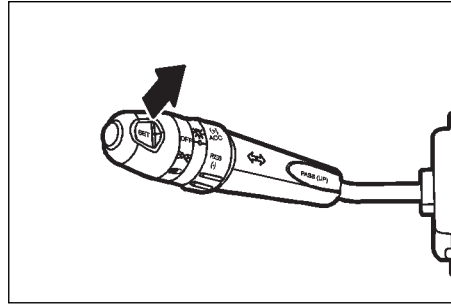

Flash (to pass) light can be controlled by moving the combination switch towards the steering wheel. It includes rest position and momentary active positions (self-return).

Direction indicator

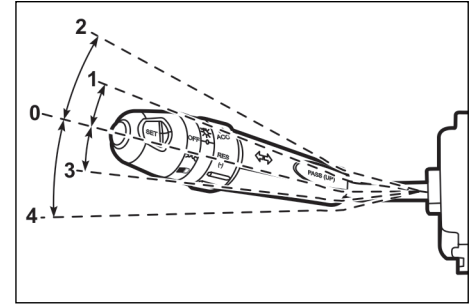

Turn signal	Combination switch position
Left	3 and 4
Right	1 and 2

The direction indicator can be controlled by moving the combination switch up and down (from neutral position) parallel to the steering wheel. When the combination switch is moved to the 1 and 3 position, the combination switch will spring back to the neutral position, if released the direction light will blink once. If the user holds the combination switch in the first position, the direction light function will be active until it's

3. EQUIPMENT DESCRIPTION AND OPERATION

released. If the user moves the combination switch to the 2 and 4 position, the combination switch does not spring back and the indicator function remains active, until deactivated manually or with the auto cancellation mechanism.

Cruise control - If equipped

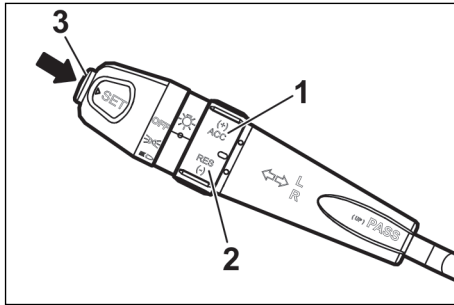

The combination switch has an optional cruise control variant with the following functions

1. CC ACC/Set + momentary switch
2. CC RES/Set - momentary switch
3. CC Activate/ Resume momentary switch.

Cruise control operation

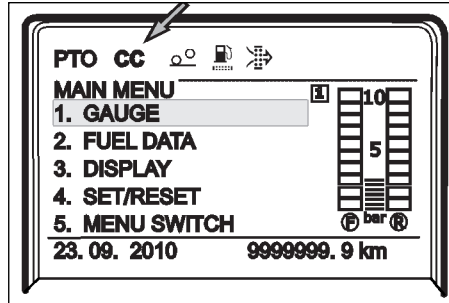

Before operating the cruise control make sure that the following conditions are met.

1. Ignition switch should be in "ON" condition.
2. Vehicle speed should be higher than or equal to 30 km/h.
3. Brake pedal should be in released condition.
4. Clutch pedal should be in released condition.
5. Transmission should be engaged in forward condition.
6. Auxiliary brake should be in OFF condition.

Cruise control should be activated after all the above said conditions are satisfied.

NOTE

If cruise control set button is pressed once again after the cruise control is activated, cruise control will be deactivated.

The speed at which the cruise control is activated is known as cruise speed. This active status will be informed to driver by status icon in the instrument cluster.

3. EQUIPMENT DESCRIPTION AND OPERATION

Cruise control speed adjustment

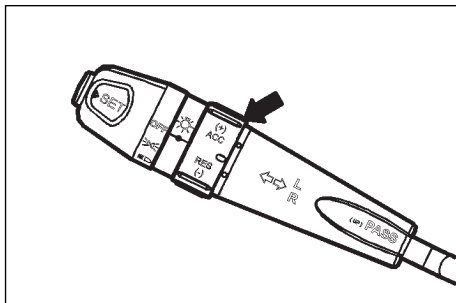

Once the cruise control is activated, the rotary knob can be used to set the target speed. ACC (+) for increasing the speed and RES (-) for decreasing the cruise control speed, the speed can also be controlled by pressing the accelerator pedal.

NOTE

Cruise control speed cannot be set above the defined maximum speed. Check with UD Trucks authorised dealer for the maximum speed limit.

Cruise control can be deactivated when;

- the cruise control set button is pressed when the vehicle is in cruise control mode.
- switching the ignition key OFF.
- the clutch is in pressed condition.
- the brake is pressed.
- the PTO is active.
- the drive line is not in forward condition.
- the vehicle speed reaches below 30 km/h.

3. EQUIPMENT DESCRIPTION AND OPERATION

3.6 Gearshift lever

6 Speed

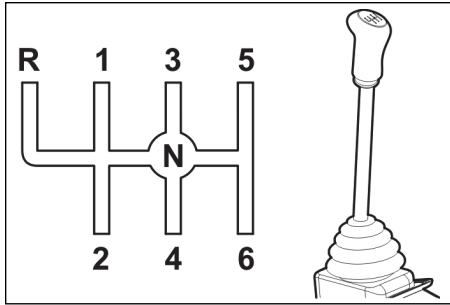

The 6 speed manual transmission comprises of six forward gears and one reverse gear,

9 Speed

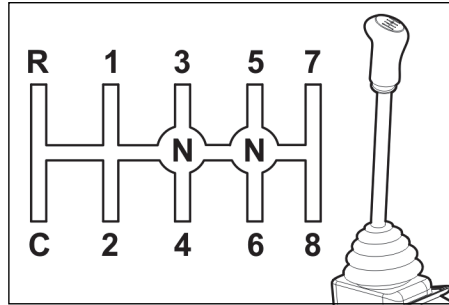

The 9 speed manual transmission comprises of 8 forward gears, an additional crawler gear and one reverse gear. The crawler gear is advised to be used when the vehicle is stuck in sand, marshes, pits etc. It can also be used when starting with a heavy loaded on a hill.

12 Speed

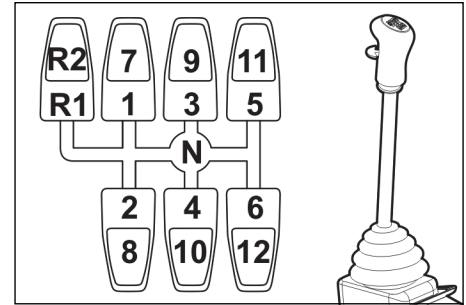

The 12 speed transmission comprises of split-range gears. Each gear is split in a “high” and “low” range, which can be selected using the small switch mounted on the front side of the gearshift lever. High range and low range shift must be done between 6th and 7th shift only.

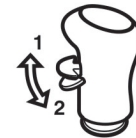

1. High range
2. Low Range

3. EQUIPMENT DESCRIPTION AND OPERATION

Range selection operation instructions

Range changes are initiated at neutral position. Hold gearshift lever for 1-2 seconds in neutral position and then select new shift position (for low range). Ensure that “low” telltale indicator illuminates in the instrument cluster, when the gear range is changed from high to low. High range and low range shift must be done between shift position 6th and 7th.

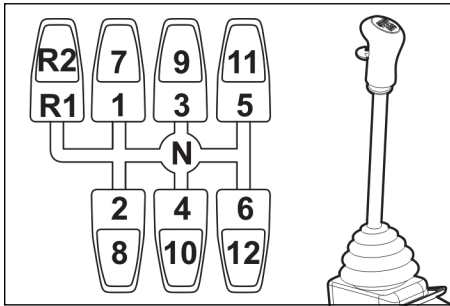

High range position R2,7,8,9,10,11,12

Low range position R1,1, 2,3,4,5,6

Range change preventive function.

This safety feature prevents range change from high to low. if the engine is running at a high RPM. Refer to the maximum allowable RPM at each shift position in the below table.

Maximum RPM for range switch (12 speed transmission)					
7th	8th	9th	10th	11th	12th
2000	1500	1200	900	700	550

Maximum RPM for range switch (9 speed transmission)			
5th	6th	7th	8th
1750	1300	950	750

Do not switch the range from High to Low, if you are exceeding the maximum RPM. when this feature prevents range change, reduce engine RPM and make shift to neutral position. Shift the gearshift lever to lower range and ensure that the “low” telltale indicator illuminates.

Overdrive gearbox- STO2009 and STO2012 - If equipped

An overdrive is a mechanism that allows the driver to drive the vehicle at sustained speed with reduced engine RPM, leading to better fuel economy, lower noise, and lower wear.

3. EQUIPMENT DESCRIPTION AND OPERATION

3.7 PTO - if equipped

PTO (Power Take Off)

The truck can be equipped with two types of PTO's, engine mounted PTO and gearbox or transmission mounted PTO. The engine mounted PTO is clutch independent and the transmission mounted PTO is clutch dependent.

The PTO enables the driver or to derive mechanical energy from the truck to activate auxiliary functions example pumps etc. A PTO can be activated and deactivated by the PTO switch on the dashboard, when the pre-set conditions are met.

NOTE

PTO is disengaged when the engine is switched OFF. When the engine is switched ON, the PTO is still disengaged despite the fact that the switch is ON. Switch OFF the PTO switch and switch ON, before engaging the PTO again.

NOTE

PTO is also disengaged when the vehicle speed is above predefined limits.

Engine mounted PTO Activate engine PTO

1. Apply the parking brake.

NOTE

Make sure parking brake is applied. The indicator in IC is illuminated.

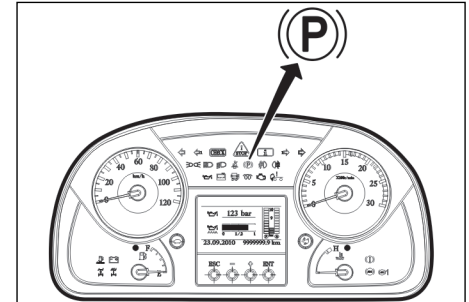

2. Switch ON the engine PTO switch on the dashboard.

3. EQUIPMENT DESCRIPTION AND OPERATION

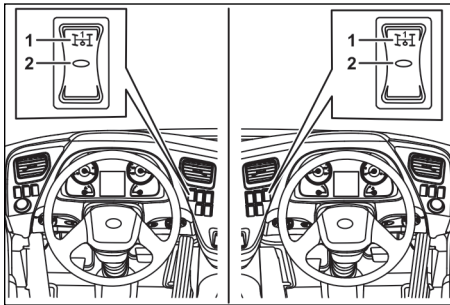

1. Engine PTO ON
2. Engine PTO OFF
3. The PTO indicator will illuminate in the display.

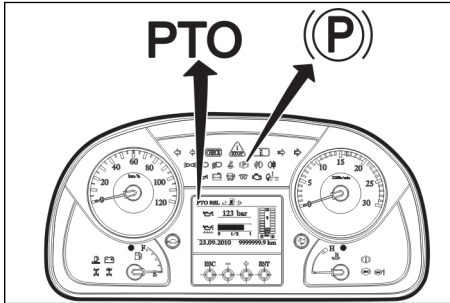

Deactivate engine PTO

- Switch OFF the engine PTO switch.

Transmission PTO

Activate transmission PTO 12 Speed

NOTE

Abrupt range switch with shift could result in disengaged gear rotation. If the gear rotation is disengaged, return to neutral position and redo shift.

1. Apply the parking brake
2. Press down the clutch pedal and shift the gearshift lever to neutral low range.

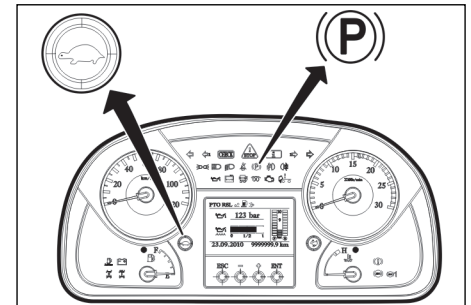

3. EQUIPMENT DESCRIPTION AND OPERATION

NOTE

Make sure parking brake is applied and the gearshift lever engaged in low range. The parking brake indicator and the low range indicator is illuminated on IC.

3. Follow the range selection operation instructions.
4. Switch ON the transmission PTO switch on the dashboard.

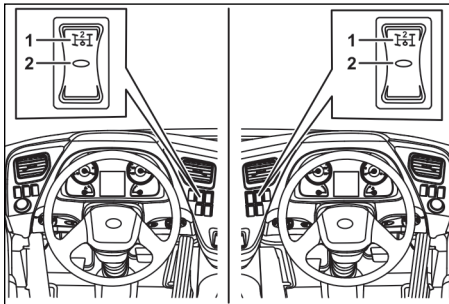

1. Transmission PTO ON
2. Transmission PTO OFF

NOTE

Make sure that gearshift lever low indicator goes OFF and PTO indicator lamp in PTO switch is illuminated.

5. Make sure that the display shows the PTO status icon.

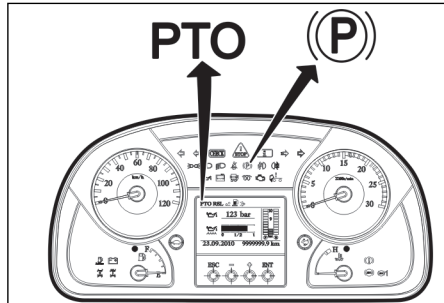

NOTE

Warning buzzer (alarm) sounds unless the parking brake is applied.

6. Engage the forward gear.
7. Release the clutch pedal.

Deactivate transmission PTO
12 speed

1. Press down the clutch pedal.
2. Shift gearshift lever to neutral.
3. Switch OFF the transmission PTO switch.

NOTE

Make sure that gearshift lever is engaged in low range. The low range indicator and PTO indicator lamp in PTO switch is OFF.

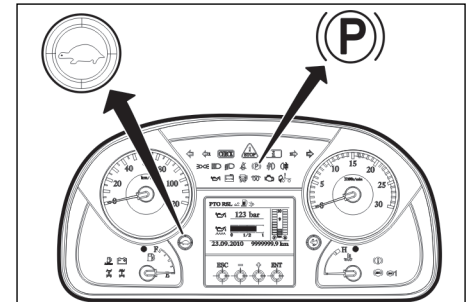

4. Release the clutch pedal.

NOTE

Transmission PTO is disengaged if the reverse gear is engaged.

3. EQUIPMENT DESCRIPTION AND OPERATION

Activate transmission PTO 9 speed

1. Apply the parking brake.

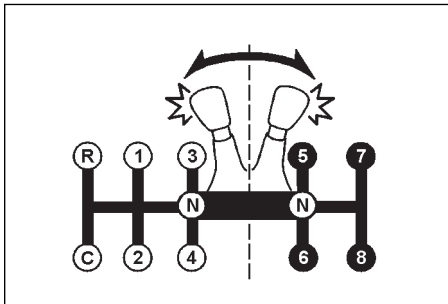
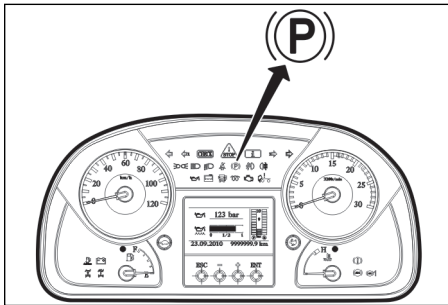

High range: 5, 6, 7, 8
Low range: C, 1, 2, 3, 4

2. Press clutch pedal and shift the gearshift lever to neutral low range.

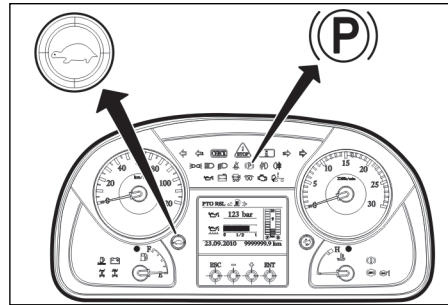

NOTE

Make sure parking brake is applied. The parking brake indicator and the low range indicator is on.

3. Follow the range selection operation instructions.

4. Switch ON the Transmission PTO switch on the dashboard.

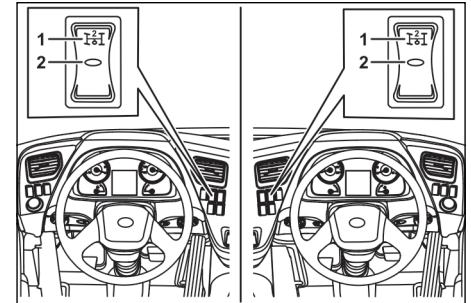

1. Transmission PTO ON
2. Transmission PTO OFF

5. Make sure that the display shows the PTO status icon.

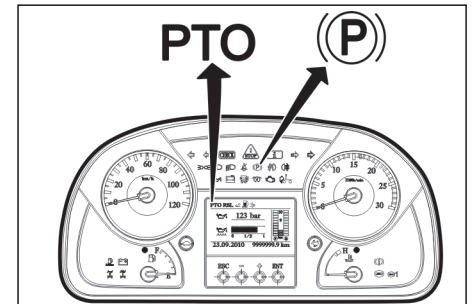

3. EQUIPMENT DESCRIPTION AND OPERATION

NOTE

Warning buzzer (alarm) sounds unless the parking brake is applied.

6. Engage the forward gear.
7. Release the clutch pedal.

Deactivate transmission PTO 9 speed

1. Press down the clutch pedal
2. Shift the gearshift lever in neutral position.
3. Switch OFF the Transmission PTO switch.

NOTE

Make sure that gearshift lever low indicator is illuminated and PTO indicator lamp in PTO switch is OFF.

NOTE

Transmission PTO is disengaged when the reverse gear is engaged.

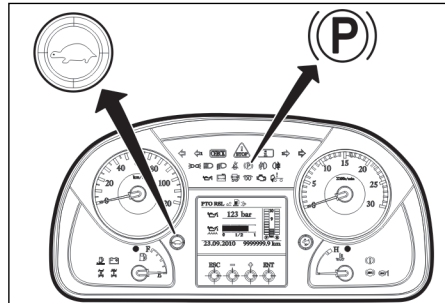

4. Release the clutch pedal.

3. EQUIPMENT DESCRIPTION AND OPERATION

Engine RPM control using combination switch during PTO operation

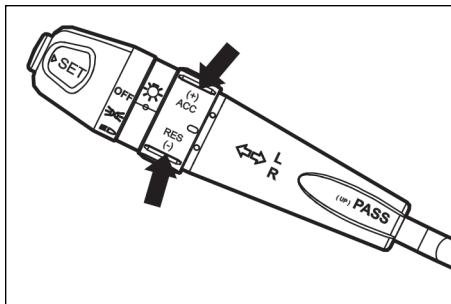

NOTE

Engine RPM can be controlled by using either accelerator pedal or by using combination switch.

When any of the PTO's (engine or Transmission PTO) is activated, use ACC/SET+ and RES/SET- buttons to increase or decrease the engine RPM. Hold on to ACC/SET+ to increase and hold on to RES/SET- to decrease the RPM. Leave the combination switch to maintain the current engine rpm.

The RPM control through combination switch will be deactivated by pressing the brake pedal or clutch pedal or deactivating both PTO's. Turning the knob again to ACC/SET+ or RES/SET- will re activate RPM control through combination switch.

3. EQUIPMENT DESCRIPTION AND OPERATION

3.8 Fuel coaching system

Description

The fuel coaching system guides the driver to operate in the best possible operating region of the engine. This is done to guide the driver through symbols displayed in the instrument cluster. The system will also help the driver to keep track of the driving behavior and driver's performance over a defined period of time or trips logged, which the vehicle owner can extract later and analyze.

The fuel coaching symbols will be activated once the vehicle reaches the speed of 30 km/h for long haul trucks and 10 km/h for construction trucks.

Following table shows the driver action list to reach the sweet spot

Description	Symbols
Not in sweet spot (out of range for guidance)	
Engine is operating in less efficient area of the sweet spot	
Engine is operating in sweet spot	
Increase engine speed by shifting to close lower gear or by applying more throttle (RPM too low)	RPM ▲
Decrease engine speed by shifting to close upper gear or by less throttle (RPM too high)	RPM ▼
Decrease the accelerator pedal (torque/ load too high)	
Increase the accelerator pedal (torque/ load too low)	

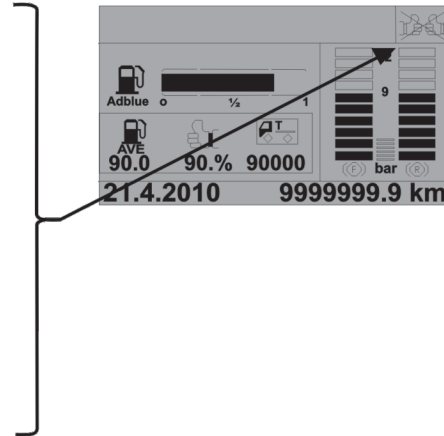

3. EQUIPMENT DESCRIPTION AND OPERATION

Fuel coaching data

Fuel coaching data (1) is displayed on the driver information display.

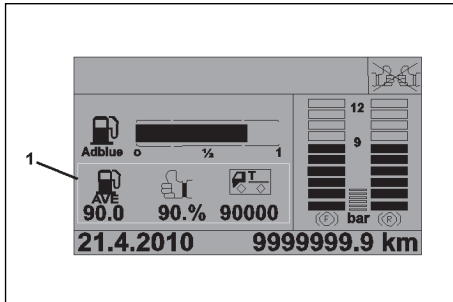

Sweet spot (fuel consumed in sweet spot)

The engine ECU will monitor the level of fuel consumed in the “Sweet Spot” and compare it with the total fuel consumed. The driver display will display the ratio between the fuel consumed in the sweet spot and the total fuel consumed over the buffer distance. This is referred to as “Sweet Spot”.

The engine is designed to allow the driver to stay within the sweet spot during most normal operating conditions. There may be situations where it is necessary to operate the engine outside the sweet spot, especially with transmissions that have large steps between the gears. However, this will negatively affect fuel consumption.

NOTE

When the user changes the mode or target value, then the fuel coaching symbols or icons active during that period of time will go OFF momentarily.

NOTE

The fuel coaching symbols or icons guide the user to know when and how much to accelerate or decelerate and when to shift gear. In a short time the user can learn the technique and can be able to drive in the sweet spot.

3. EQUIPMENT DESCRIPTION AND OPERATION

Sweet spot data logging

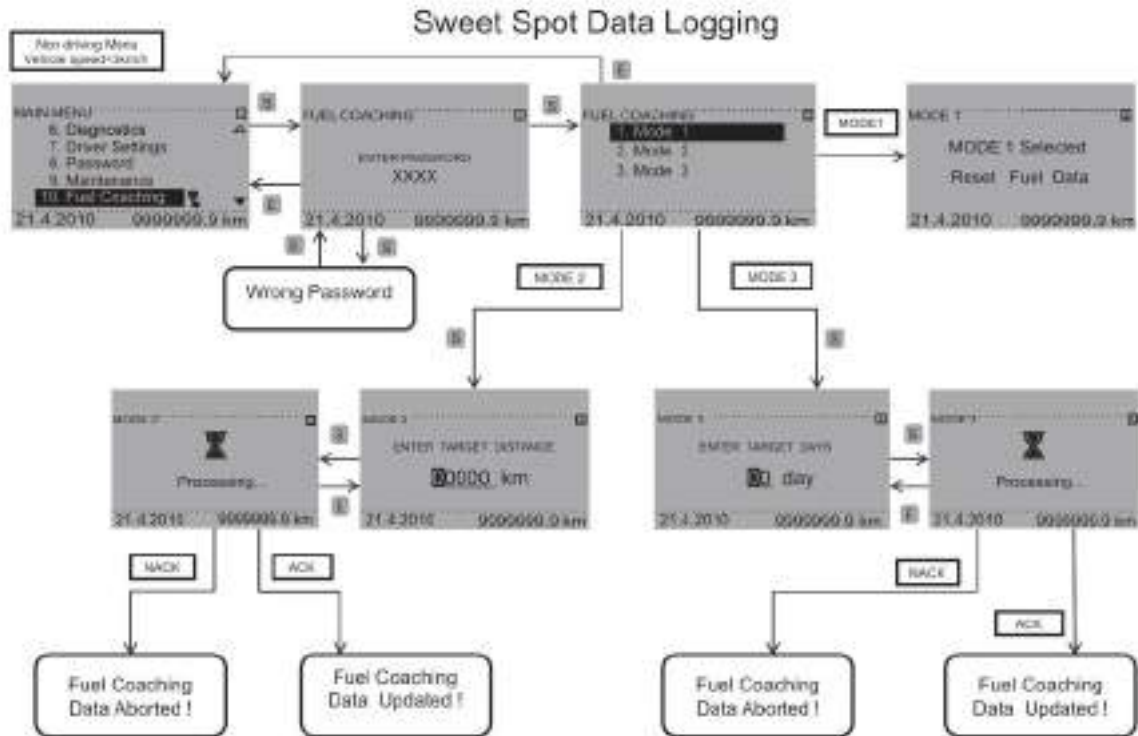

3. EQUIPMENT DESCRIPTION AND OPERATION

3.9 Fifth wheel operation

The fifth wheel operation is applicable only for the truck tractor, Quester series tractor can have any of the below two fifth wheels

- Fifth wheel, pressed H150
- Fifth wheel, pressed H185

Pre service inspection

Before starting the coupling procedure, inspect the base of the fifth wheel, the bearings, the lock, the wear ring and the hook for missing or damaged parts. Also check to see if any of the bolts attaching the fifth wheel to the chassis of the tractor vehicle are loose or missing.

The trailer and the tractor must be resting on the same flat surface which must not give under the pressure of the load transmitted through the tyres and the lifting device.

Fifth wheel must be cleaned and lubricated.

Tilt the ramps in downward condition.

Make sure that the locks are open. If locks are closed, follow the below steps to unlock the pin.

1. Grip hold the handle,
2. Remove safety clip from hole.
3. Slide handle back to disengage the lock.
4. Pull the handle out.
5. Secure the handle notch on unlock pin.

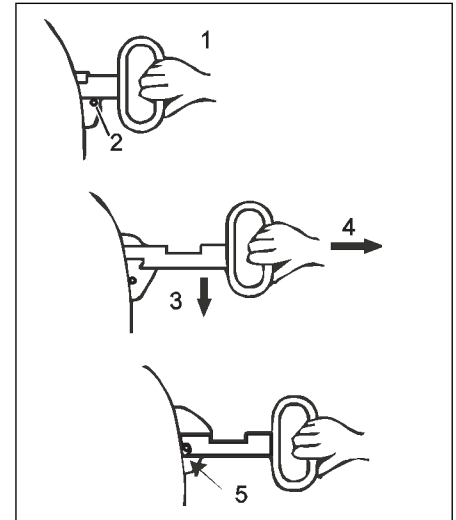

3. EQUIPMENT DESCRIPTION AND OPERATION

Coupling procedure

WARNING

The trailer and the tractor must be resting on the same flat surface which must not give under the pressure of the load transmitted through the tyres and the lifting device.

Align the king pin center with fifth wheel center

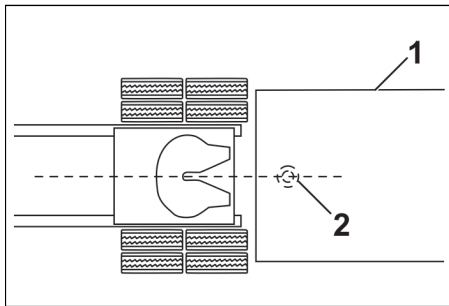

- 1. Trailer top
- 2. King pin position

1. Bring the tractor close to the trailer.

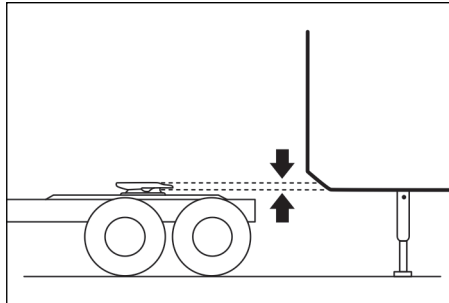

2. Chock the trailer wheels. Connect the brake lines and light cord. Support slack in lines to prevent interference.
3. Make sure that the trailer wear plate is slightly below the fifth wheel.

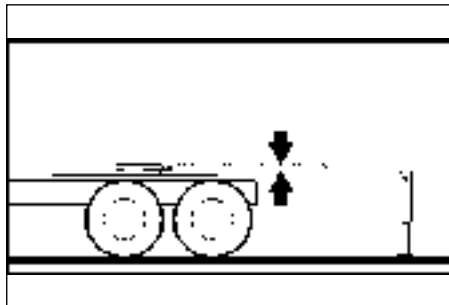

Trailer should contact fifth wheel 100-150 mm behind the fifth wheel bracket pin.

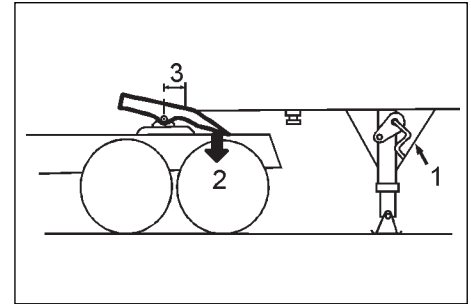

1. Use low gear to operate landing gear
2. Fifth wheel tilted position
3. 100-150 mm
4. Move the tractor vehicle in slow speed towards the semitrailer, keeping them aligned until coupling occurs.
5. Apply the parking brake of the tractor vehicle.
6. Check that the semitrailer platform is resting on the fifth wheel and that there is no clearance. If clearance is found, repeat the entire coupling procedure.

3. EQUIPMENT DESCRIPTION AND OPERATION

WARNING

The coupling procedure is not complete without visual inspection. The driver must get out of the tractor and verify that the fifth wheel is properly coupled to the king pin as shown below.

Handle secured with safety pin inserted in hole.

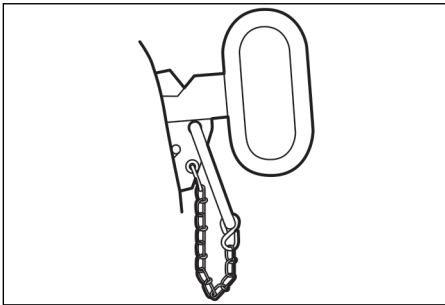

There should be no gap (1) between the trailer and fifth wheel.

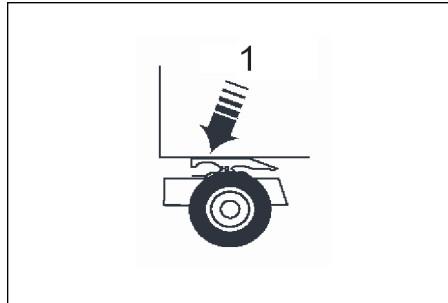

Lock should be engaged around the king pin and hook should be engaged behind lock.

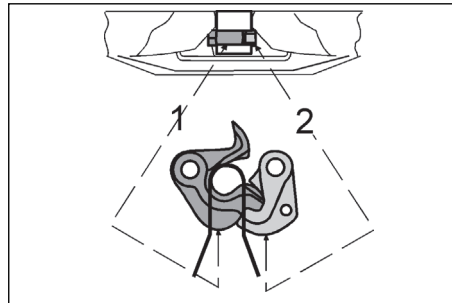

1. Lock engaged around kingpin
2. Hook engaged behind lock

Visually inspect the air connections and ensure that they are working fine and free from compressed air leaks. If there are any compressed air leak, find and seal it.

Make sure that the electric socket works perfectly by turning on the brake lights and the direction indicator lights and ensuring that they meet legal requirements.

Make sure that the air pressure in the tractor vehicle is correct by reading the pressure gauge on the instrument cluster. The tractor vehicle will only be ready to move when the air pressure reaches the minimum established level.

Keep the brakes applied on the trailer, return the landing gear to previous position and make sure that the trailer brake are working properly. Release the parking brake on the tractor vehicle and ensure that the fifth wheel remains engaged when the trailer is moved forwards. If it does not remain engaged, repeat the complete coupling procedure.

3. EQUIPMENT DESCRIPTION AND OPERATION

Check the clearance between the locking mechanism and the king pin by moving the tractor vehicle forwards and backwards. If the clearance is excessive, consult nearest **UD Trucks** authorised dealer.

WARNING

Do not use any fifth wheel that fails to operate properly.

De-coupling procedure

WARNING

The trailer and the tractor must be resting on the same flat surface which must not give under the pressure of the load transmitted through the tyres and the lifting device.

The semitrailer and the tractor vehicle must be on the same flat surface. This surface must not give under the pressure of the load transmitted through the tyres and the lifting device.

Ensure that the semitrailer does not pull the tractor vehicle.

Apply the semitrailer brake and the parking brake of the tractor vehicle to chock the semitrailer wheels.

Lower the lifting device, take proper care not to raise the semitrailer platform on the fifth-wheel base.

Unlock the fifth wheel with release handle as follows.

1. Unlock the safety pin.

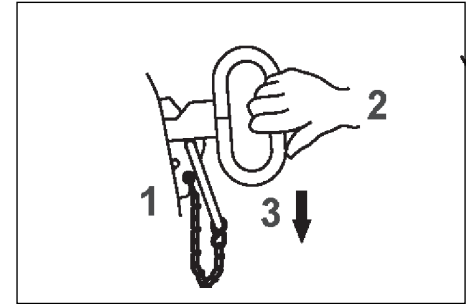

2. Grip hold the handle.
3. Slide the handle back.
4. Pull out the handle.

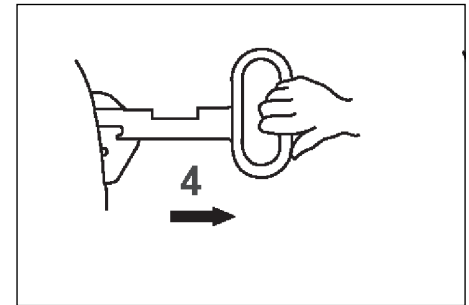

3. EQUIPMENT DESCRIPTION AND OPERATION

5. Hook the handle notch on unlock pin

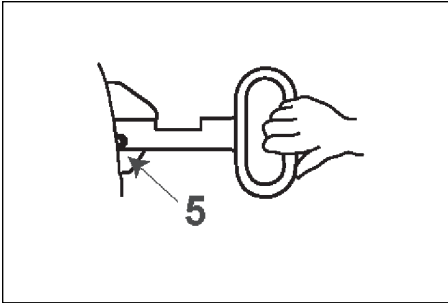

Disconnect the air hoses and the electric socket by returning them to their holders (using safety equipment which is suitable for this operation) release the tractor brake and slowly drive away from semitrailer.

3. EQUIPMENT DESCRIPTION AND OPERATION

3.10 Differential lock

Information

CAUTION

Do not turn the vehicle with differential lock applied. It could damage the axle if you turn the vehicle with differential lock applied.

The purpose of the differential lock is to provide maximum traction and control of the vehicle on terrain and roads in adverse conditions.

1. On a firm surface, it is not required to apply differential lock as the wheels can rotate freely.

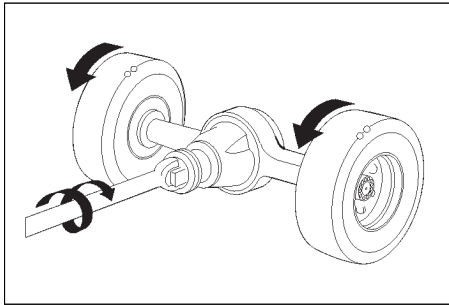

2. Without applying differential lock while driving on a slippery surface the wheel on the slippery surface turns and the vehicle remains stationary.

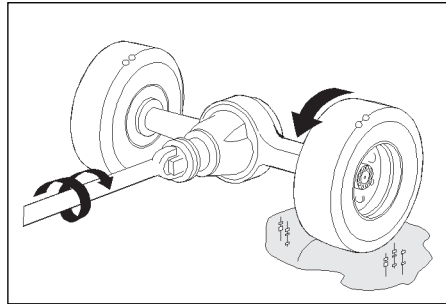

3. While driving on a slippery surface deactivate the differential lock only when both wheels are gripping normally.

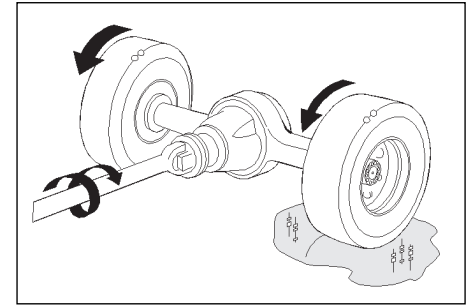

The differential lock can be locked or unlocked if the vehicle is stationary.

When the differential lock is on, the vehicle should move at low speeds, below **40 km/h**.

3. EQUIPMENT DESCRIPTION AND OPERATION

Always unlock the differential lock as soon as the vehicle emerges from slippery surface conditions and returns to a road with a good surface.

WARNING

Do not activate the differential lock when the vehicle is on a steep downhill slope. Doing so can result in loss of vehicle stability.

The vehicle may be equipped with either of the two switches.

- Differential lock switch interaxle
- Differential lock switch interaxle and rear wheels.

Differential lock interaxle switch

CAUTION

If the driver fore see a possible slippery, sliding surfaces the differential lock inter-axle switch should be activated at stand still and before reaching these areas. If activated when slipping or skidding it could damage the axles.

If the wheels are skidding, sliding or losing traction, engage the differential lock switch located on the instrument cluster.

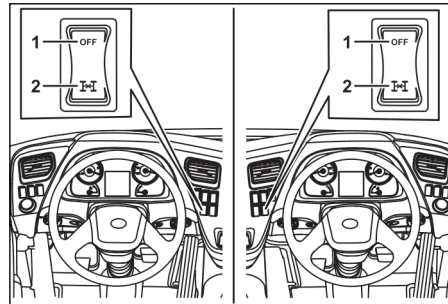

1. OFF
2. Diff lock interaxle ON

Differential lock interaxle and rear wheels switch (only for RTH2611)

The differential lock switch (interaxles and rear wheels) has three positions.

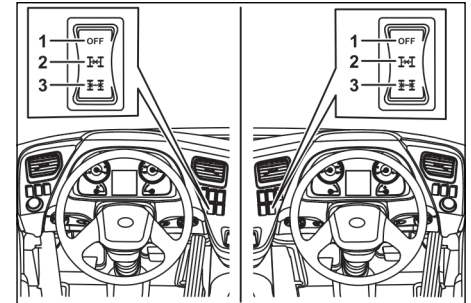

1. OFF
2. Diff lock interaxle ON
3. Diff lock interaxles and rear wheels ON

1st position: This deactivates the differential lock. In this position the telltale indicator in the cluster does not illuminate.

2nd position: The differential lock between the axles is applied. The telltale indicator on the instrument cluster illuminates.

3. EQUIPMENT DESCRIPTION AND OPERATION

3rd position: The differential lock between the axles and rear wheels are applied. The telltale indicator on the instrument cluster illuminates.

NOTE

The control lamp may only light up when the vehicle starts to move.

Differential lock operation

CAUTION

Drive carefully when the differential lock is applied. In order to avoid damages to the drive axle and gear, never turn or drive on firm surfaces with the differential lock applied.

NOTE

Apply the differential lock before the vehicle moves into a slippery surface. Remove the differential lock after leaving the slippery surface.

1. Stop the vehicle.
2. Check that none of the wheels are skidding.
3. Press the clutch pedal.
4. Activate the differential lock.
5. Release the clutch pedal and accelerate carefully.
6. Drive few meters from the slippery surface.
7. Release the accelerator pedal.
8. Deactivate the differential lock.

NOTE

The differential lock is not engaged until the telltale indicator in the instrument cluster illuminates. The differential lock is still engaged as long as the telltale indicator is illuminated, even if the switch is turned OFF.

CAUTION

If the differential lock indicator remains illuminated even after switching off the differential lock switch. Stop the vehicle and contact nearest UD Trucks authorised dealer for assistance.

3. EQUIPMENT DESCRIPTION AND OPERATION

3.11 Bogie control - if equipped

Bogie control

Bogie lift assembly makes it possible to lift the tag axle when the drive axle load is less than the rated load or when the vehicle is in unladen condition. When the vehicle is in unladen condition, the tag axle should be lifted. This is achieved by filling air bellows.

There are three operating conditions.

- Normal condition
- Bogie press condition
- Bogie lift condition.

Different conditions can be achieved by pressing the bogie lift switch provided on the cabin dashboard.

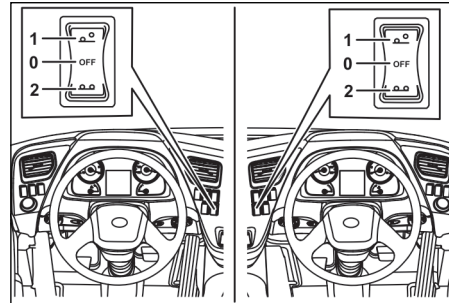

0. Bogie lift OFF- Red
1. Bogie lift -Amber
2. Bogie press- Amber

Normal condition

Bogie lift switch in OFF condition. When the vehicle is fully loaded (rated load), it is to be considered as normal condition. During this condition the drive and tag axles, will be in contact with the ground. There will be normal set pressure in the bellows.

3. EQUIPMENT DESCRIPTION AND OPERATION

Bogie press condition

When the vehicle is fully loaded (rated load) and moving on the gradient or on a slippery road surface, vehicle will not get sufficient traction to move. The drive axle starts slipping. Driver need to press the bogie lift switch to press condition (2) on the dashboard. Once the switch is pressed, the solenoid valves opens and it will start filling the air in the bellows to set pressure. The bellow will expand and will try to lift the tag axle OFF the ground, but not completely. This will transfer some load from the tag axle to the drive axle. The drive axle will get sufficient traction to move on the vehicle. Once the vehicle comes out of this problem of traction, driver should press the switch to normal condition again to bring the tag axle to its normal position.

NOTE

Driver should not keep running the vehicle in the bogie press condition for long time.

Bogie lift condition

When the vehicle is in unladen or partially laden condition (less than the rated capacity of drive axle), driver can lift the tag axle completely from the ground by pressing the bogie lift switch provided on the dash board. Once the switch is pressed, the solenoid valves will open and it will start filling the air in the bellows up to the set pressure. The bellow will expand and will lift the tag axle OFF the ground completely. This will transfer all load from the tag axle to the drive axle. It saves unnecessary wear and tear of the tag axle tyres, which in turn increases the life of the tag axle tyres.

NOTE

During lift, ensure the drive axle will not cross its loading capacity.

3. EQUIPMENT DESCRIPTION AND OPERATION

3.12 Coupling - if equipped

Hitching

NOTE

The relevant national regulations must be observed when hitching and unhitching.

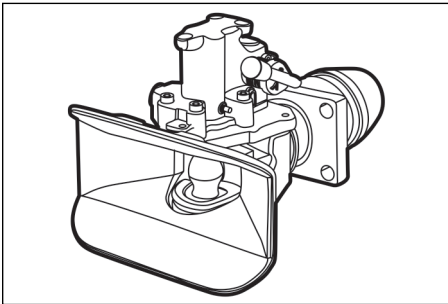

Make sure that nobody is standing between the tractor and trailer.

1. To engage, press hand lever upwards until it engages.
2. Check whether funnel is locked.
3. Position drawbar eye in centre of the funnel.

4. Disengage brake on front axle of turntable drawbar trailer.
5. Slowly reverse tractor.

When hitching a trailer

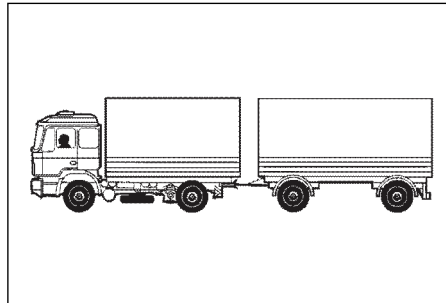

- Reverse tractor truck very slowly
- The drawbar eye must be inserted into the middle of the funnel, else the funnel, the drawbar eye or the drawbar landing legs might be damaged.

WARNING

After each hitching procedure, it is essential to check that the hitch is correctly closed and locked. The lock-control pin must not extend out of its guide after hitching. If the lock-control pin extends from its guide, the hitching procedure has been carried out incorrectly and there can be risk of an accident.

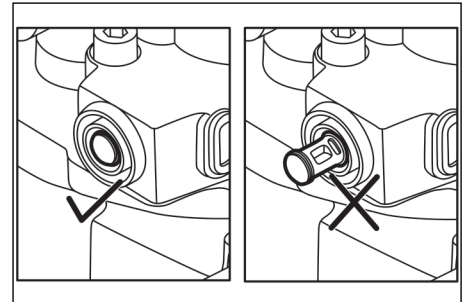

3. EQUIPMENT DESCRIPTION AND OPERATION

Do not drive the tractor with the lock control pin in extended condition. Move the tractor approximately 1 m and check again if the coupling is secured.

Closing the coupling manually



WARNING

Ensure care to avoid injury.

1. Release coupling pin with suitable tool.
2. Strike hand lever knob briefly in opening direction with heel of hand.

3. EQUIPMENT DESCRIPTION AND OPERATION

3.13 Others

Horn

To sound the horn, push the center pad area of the steering wheel.

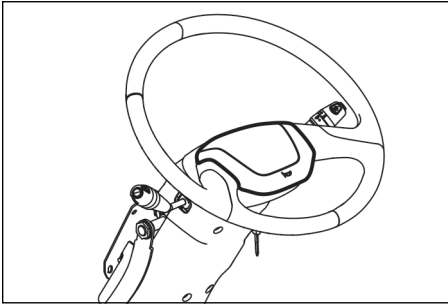

It can be selected for air or disc horn by operating the horn selector switch on the dashboard.

Sun visor

Sun visors are located on the interior just above the windshield designed with a hinged flap that is adjustable to help shade the driver's and co-driver's eye from the glare of sunlight.

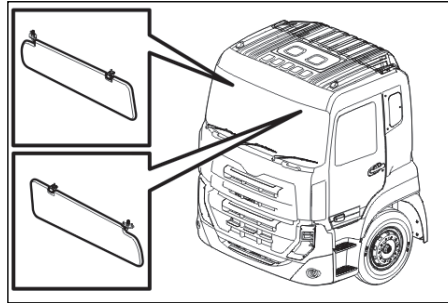

3. EQUIPMENT DESCRIPTION AND OPERATION

Engine protection

Engine protection controls the functions used to protect the engine from damage. When a critical condition arises (coolant temperature too high, low coolant level, etc.), the engine may temporarily be restricted to protect the driveline.

The following are monitored:

- High engine coolant temperature
- Low engine coolant level
- Low engine oil pressure
- High engine over-speed
- Air filter, low pressure
- Low pressure fuel filter

When a monitored component/function nears the critical state, the driver is warned by caution lamp, text and/or buzzer. The driver warning is activated. Driver warnings are shown to the driver only when the driver can take a corrective action, other warnings will be suppressed.

The actions that can be taken by the system when engine protection is activated are:

- Light yellow caution lamp turned on
- Light red stop lamp turned on
- Reduce maximum torque
- Reduce maximum engine speed
- Reduce maximum road speed
- Force the engine to idle after certain time
- Shutdown the engine after certain time (vehicle is stationary).

3. EQUIPMENT DESCRIPTION AND OPERATION

Front panel opening

The following items can be inspected by opening the front panel.

- Clutch fluid level
- Coolant level
- Washer fluid
- Nylon filter for AC



WARNING

Make sure that the front panel is locked before driving. When inspecting inside the front panel, always make sure that the wiper switch is OFF. If the wiper switch is ON, there can be risk of injury during inspection.

1. Pull the knob towards driver seat to release the front panel lock.

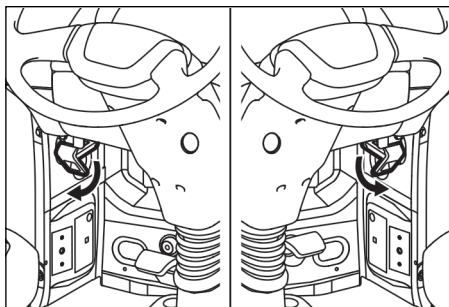

2. Open the front panel with spring extended.

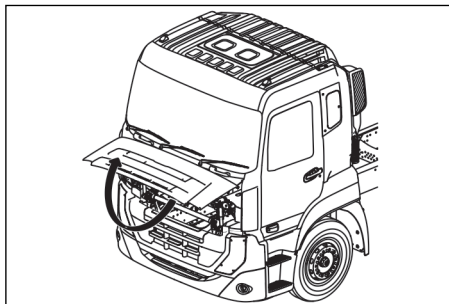

Front panel closing

1. Lower the front panel slowly.

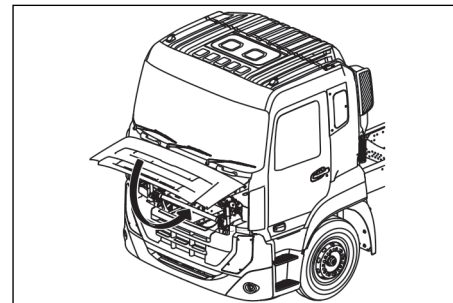

2. Push the front panel gently until it clicks into place.
3. Make sure that the front panel is locked.

4.ACCESSORIES AND AUDIO

4.1 Accessories

Storage box

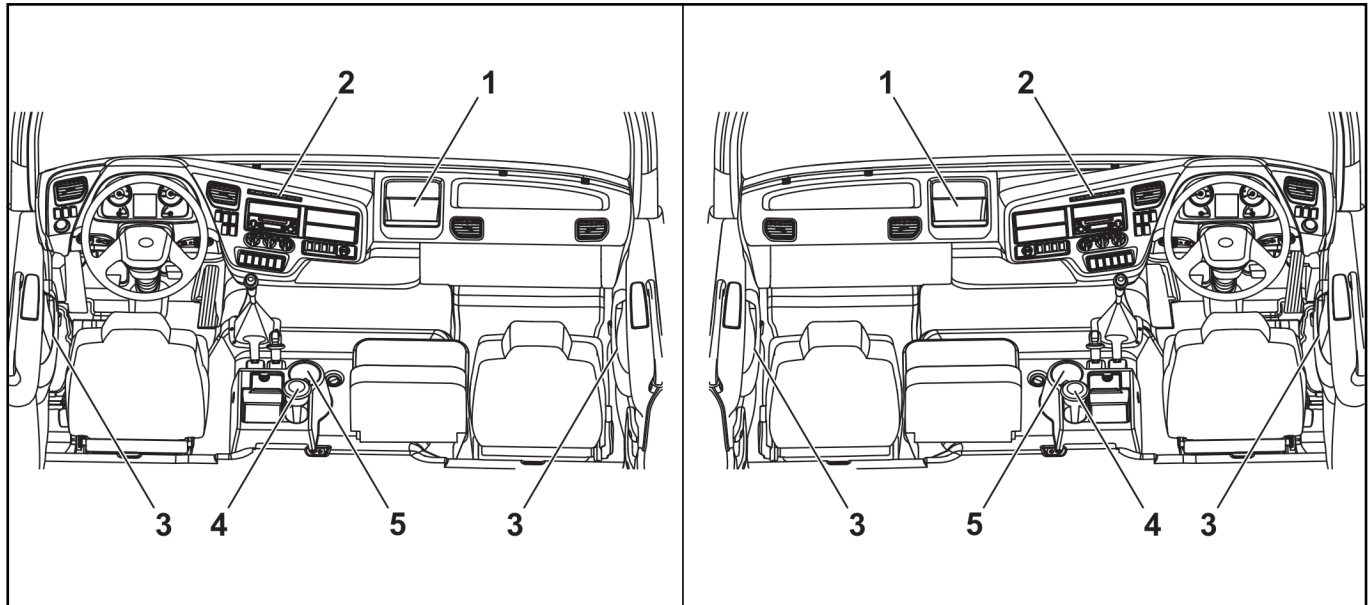

- 1. Storage box
- 2. Card holder
- 3. Door pocket
- 4. Ash box
- 5. Cup holder

4.ACCESSORIES AND AUDIO

Head console (CAB-SLP)

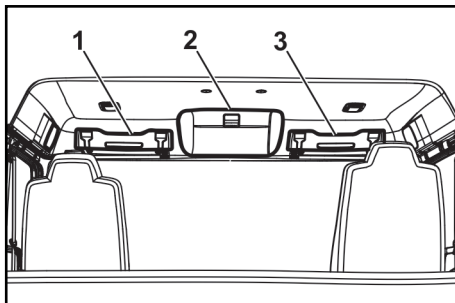

Head console (CAB-XXSL)

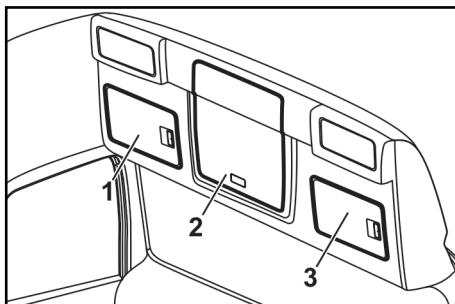

1. Passenger side head console
2. Glove compartment box
3. Driver side head console

WARNING

Do not overload or place heavy objects in the head console. Always keep the head console closed while driving to prevent loose objects in the console to fall on the driver while driving, which can cause accidents.

Cup holder

This is used to hold bottle and cup.

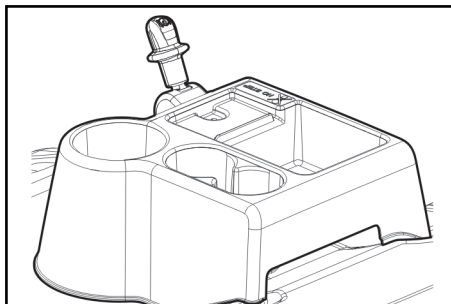

Card holder

This can be used to hold toll tickets, cards as telephone cards and highway card.

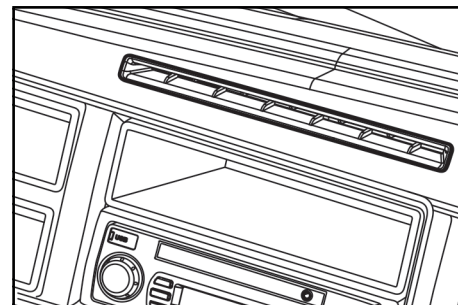

4.ACCESSORIES AND AUDIO

Door pocket

Door pockets are located in the right and left doors. Place road maps, magazines, etc. inside it. Do not place foot, or stuff the door pocket with heavy objects.

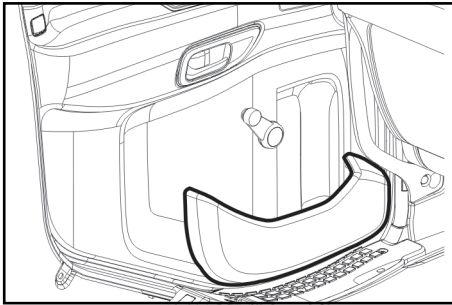

Power outlet

There is power outlet provided on the dashboard for mobile charging and others. The maximum electric current limit is 5 A and 24 V.

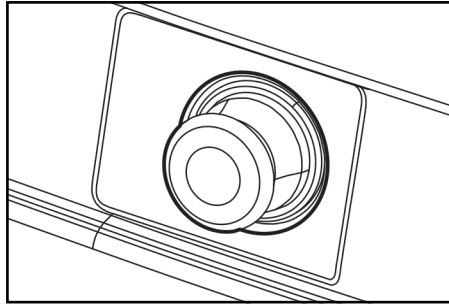

Ash box

Open the lid of the ash box to use it. Always close the lid after use. To clean ash box pull it upwards and out.

WARNING

- Do not put paper waste, empty cigarette cartons, etc., in the ash box.
- Clean the ash box before driving.
- Make sure that the cigarette is extinguished and the ash box lid is closed before leaving the vehicle.

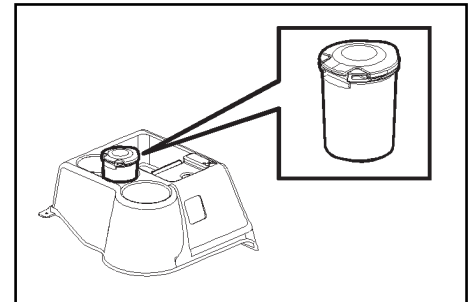

4.ACCESSORIES AND AUDIO

4.2 Audio front panel - if equipped

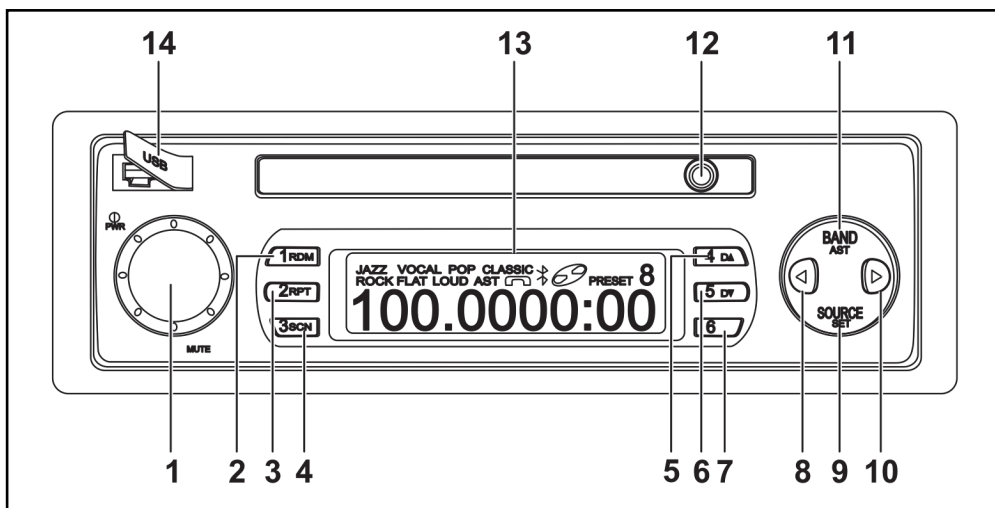

1. PWR: Press: Mute/Power on Press and hold (more than 2 sec): Power off ROTARY Volume switch	6. 5: Preset button 5 (tuner) D▼: Select next folder	11.: BAND: Press: FM/AM player mode AST: Press and hold: Auto store
2. 1: Preset button 1 (tuner) RDM: MP3 random track on/off	7. 6: Preset button 6 (tuner)	12: Aux in
3. 2: Preset button 2 (tuner) RPT: MP3 repeat track on/off	8. ◀: Select previous track (MP3 player)	13: LCD Display USB port
4. 3: Preset button 3 (tuner) SCAN: MP3 scan track on/off	9.: SOURCE. Press: Select sourcing. (USB/AUX) SET: Press and hold: Enter setup mode	14: Mini USB port
5. 4: Preset button 4 (tuner) D▲: Select previous folder	10 ▶: Select next track (MP3 player)	

4.3 Audio

ON/OFF

Press the power button to switch ON or press and hold power button (more than 2 seconds) to switch OFF.

Volume

Turn the volume knob to adjust the volume level.

NOTE

Adjust the volume so that the horns, sirens and traffic sounds can be heard clearly.

Audio setting

Press and hold SET button to enter audio setting mode.

In audio setting mode, press ◀ and ▶ to switch the audio setting items.

Turn the volume knob to change the item value:

- REF (5,23)
- BEEP(OFF,1,2,3,4,5)
- LOG (ON, OFF)
- BASS TRE (FLAT, JAZZ, VOCAL, POP, CLASSIC, ROCK)
- BASS(-7,+7)
- TREBLE(-7,+7)
- BALANCE(-7,+7)
- LOUD(OFF,LOW,MID,HI)

After 1 minute, without any setting operation, unit will automatically exit the audio setting menu.

NOTE

You can adjust the “BASS”, “TREBLE”, “BAL” and “LOUD” audio mode only in the “SET” mode.

4.ACCESSORIES AND AUDIO

4.4 Radio

Waveband

Press BAND to select the desired band:

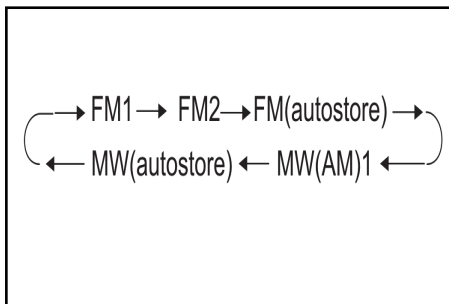

Auto Searching

Press ► button to tune to a station of higher frequency or ◀ for lower frequency.

Manual tuning (if the frequency of the required station is known)

Press and hold ◀ or ► to enter manual tuning mode. Then press ► to tune to a higher frequency or ◀ for a lower frequency.

After about 8 seconds without operation, system will return to auto searching mode.

Automatically storing stations (Auto-store)

You can store 6 strongest FM stations on the FM AST band, store 6 strongest AM stations on the AM AST band. Press and hold AST to activate auto-store. The unit will give a beep sound and then mute, the display will blink. When it has finished, you will hear a beep sound again, and the display will stop blinking.

NOTE

Keep the sound level to 3 or above to hear the beep sound.

NOTE

When you use Auto Store, the new stations will replace any previously stored stations in the FM AST band/ AM AST. Sometimes it may not be possible to find 6 stations.

Preset stations (1-6)

You can manually store one favorite station in a preset, and recall by using the preset buttons (1 to 6)

Press and hold the desired preset button (1 to 6) for more than 2 seconds (till you hear a “beep” sound) to store the current tuned station.

Recalling a preset

Press the desired preset button (1 to 6) to recall the stored station.

4.5 USB player

USB player

USB memory device can be connected to the standard mini USB interface provided on the radio panel to listen desired music.

USB memory music decoding clarification

File format: *.mp3, *.MP3.WMA

Support memory size: 32MB ~ 2GB flash memory device.

File Systems: FAT16 AND FAT32.

Sample Rate: 8k, 11.025k, 12k, 16k, 22.0k, 24k, 32k, 44.1k, 48 kHz, but all the correspondence sample rates are converted into 44.1 kHz.

Bit Rate: 8k ~ 320kbps and VBR (MP3 PRO)

Link external USB memory device

If the external USB memory device is linked correctly with the mini USB interface, press SRC key to enter USB player mode. LCD will display "USB" logo.

NOTE

The unit will initialize and search MP3 files when an USB memory device is inserted into the with mini USB interface. This will take several seconds. Do not unplug the USB memory device from the USB interface.

Playing

While playing music on the USB memory device, the display will show: Audio mode (Jazz, Pop if selected), current playing track number and the play time every 10 seconds.

Previous / next track

Press ► or ◀ to select the next/previous track.

Track scan

Press SCN to activate/deactivate scan track. The scan function will play the first 10 seconds of each track. Resume normal playing mode by pressing SCN again.

Previous / Next folder selection

Press D▲ to select previous folder.

Press D▼ to select next folder.

NOTE

Do not unplug the USB memory device from the mini USB interface when playing music from the USB source. This will damage the music files in the USB memory device. Unplug the USB memory device after turning OFF the unit.

4.ACCESSORIES AND AUDIO

4.6 Setup

Modify the initial settings on the unit according to the preference of the user.

Press SET button for more than 2 seconds to enter the SETUP menu.

Press ► or ◀ button to select one of the options that has to be modified.

Turn volume knob to alter the choice.

Press SET button for more than 2 seconds to leave the SETUP menu.

The unit will leave the SETUP mode about 1 minute after the last operation.

OPTION	Choice	Usage
(► or ◀)	(SETUP)	Long press of this button enters the SETUP mode
REF	05-23	To select the start volume
BEEP	[OFF, 1~5]	To select the beep sound volume.
LOG	[ON, OFF]	Select 'ON' to limit the use of the unit to one hour or Select 'OFF' to prevent the unit from turning on when the car ignition is switched off.
BASS TRE	[FLAT,JAZZ,VOCAL POP,CLASSIC,ROCK]	Select the Bass-Tre option
Bass	-7 ~ +7	To select the Bass level
Treble	-7 ~ +7	To select the Treble level.
BAL	-7 ~ +7	To select the Balance level.
LOUD	[OFF, LOW, MID, HI]	To select the Loudness.

4.7 Check before requesting service

Sometimes if the user suspects that the radio is not working well, check the operating/installation instructions as per the following list to identify an apparent malfunction that can easily be rectified before calling for service.

SYMPTOMS	POSSIBLE CAUSE / REMEDY
GENERAL	
Unit does not function and there is no display	Check fuse and connections
Unit functions but with no or poor sound	Adjust volume of unit to un-mute Check fader and balance settings Check the aerial and its connection
RADIO	
Poor radio reception	Check that the antenna is fully extended and properly connected Check that the negative terminal is connected to the earth (chassis)
USB MODE PLAYER	
Some files cannot be played	Please check the music files to see whether they are in MP3/WMA format. This head unit does not support other formats.
Cannot display Artist/ Track/ Album info	This unit do not support ID3 information display.
Cannot read the music from memory device	Make sure the memory device format is FAT16 or FAT32. If it is not, reset it as FAT16 or FAT32 to suit the requirements of this head unit.
Cannot play MP3 music with cables which has several USB interfaces	This head unit supports only single USB interface cable.
Pop sound / Cacophony sound	Maybe the abnormal sound is from the source music or device. Check it with another player.

Please send the unit for service if the user could not rectify the fault. The user should not try to open and service the unit.

THIS PAGE HAS BEEN LEFT
BLANK INTENTIONALLY

5. AIRCONDITIONING

5.1 Ventilation

Door window/Power window - If equipped

The power window switch provided on the driver side consists of controls to open and close the windows for both the driver and passenger side. Pressing the switch (1) operates the driver side power windows and (2) operates the passengers. It can be operated only when the ignition switch is in ON position.

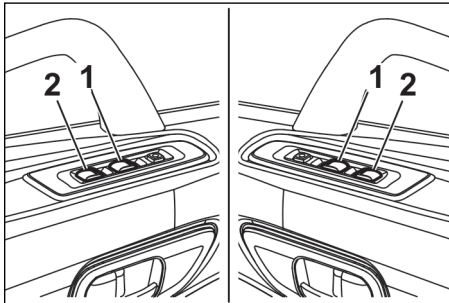

Opening and closing the window driver side - If equipped

The driver's side power window switch is used to open or close the window. when pushed (1) or pulled (2) lightly (1st stage) or automatically, when further pushed (3) or pulled (4) to 2nd stage.

1st stage (manual):

The window stops in its current position when the switch is released.

2nd stage (automatic):

The window continues moving until fully closed or fully open even when the switch is released.

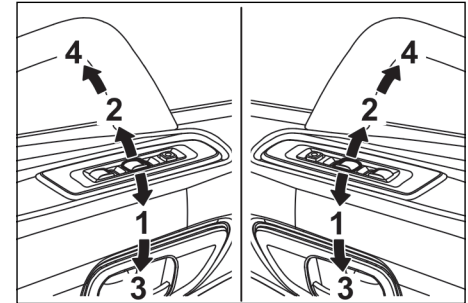

WARNING

Make sure that no body parts are extended outside the window while operating the switch. Failing to do so might result in injuries.

5. AIRCONDITIONING

Opening and closing of window- Manual

The window opening/closing levers are provided on inside of each door.

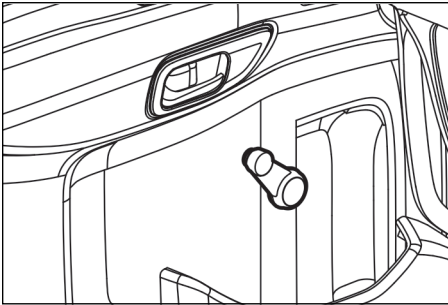

Opening and closing the passen- ger's side window

The passenger's side power window switch (1) is provided inside the passenger's doors. The window moves down when the switch is being pushed and stops when it is released. Pull the switch to raise the window.

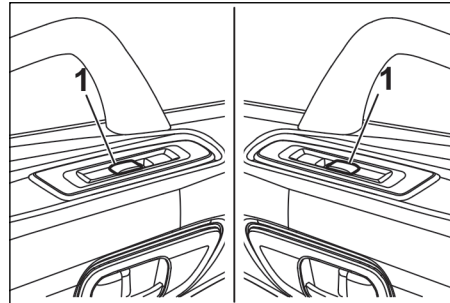

5.2 Air conditioner

Air vent

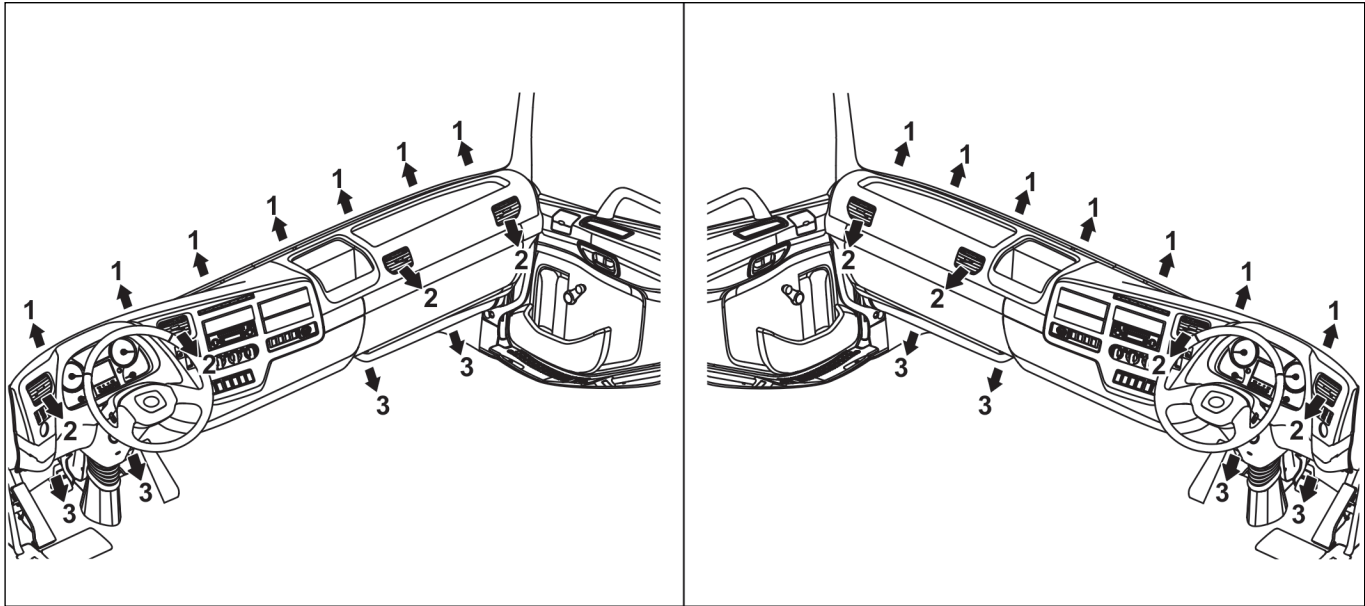

- 1. Air blowing to wind shield
- 2. Air blowing to upper body
- 3. Air blowing to foot rest

CAUTION

Do not switch ON the blower when the engine is switched OFF, it could drain the battery.

5. AIRCONDITIONING

Manual Air-Conditioner



DANGER

Do not switch on the air conditioning system and sleep or stay for a prolonged time in the vehicle with windows closed. Failure to comply can lead to death due to non availability of oxygen.

The control panel (CP) used will have the following 8 variants.

- 1 Mechanical controlled HVAC-LHD
- 2 Mechanical controlled Heater unit-LHD
- 3 Mechanical controlled only AC-LHD
- 4 Mechanical controlled vent unit-LHD
- 5 Mechanical controlled HVAC-RHD
- 6 Mechanical controlled Heater unit-RHD
- 7 Mechanical controlled only AC-RHD
- 8 Mechanical controlled vent unit-RHD

Mechanical controlled HVAC-RHD

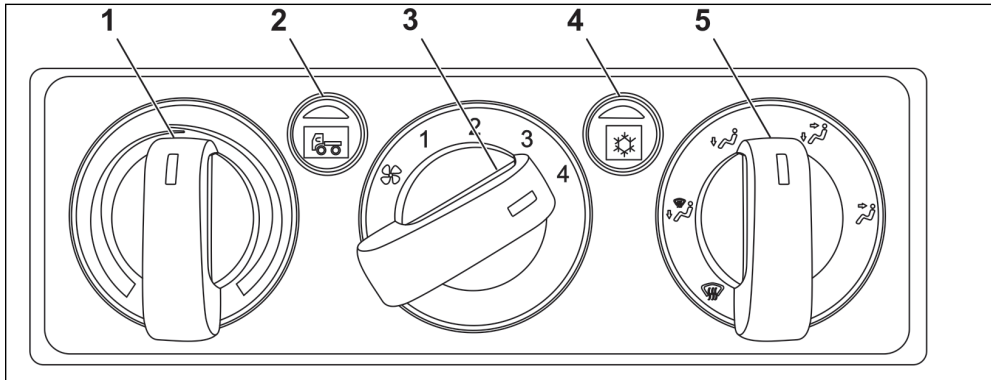

- 1. Temperature control knob
- 2. Fresh/recirculation switch
- 3. Blower knob
- 4. Cooler ON/OFF switch
- 5. Mode knob

Mechanical controlled HVAC-LHD

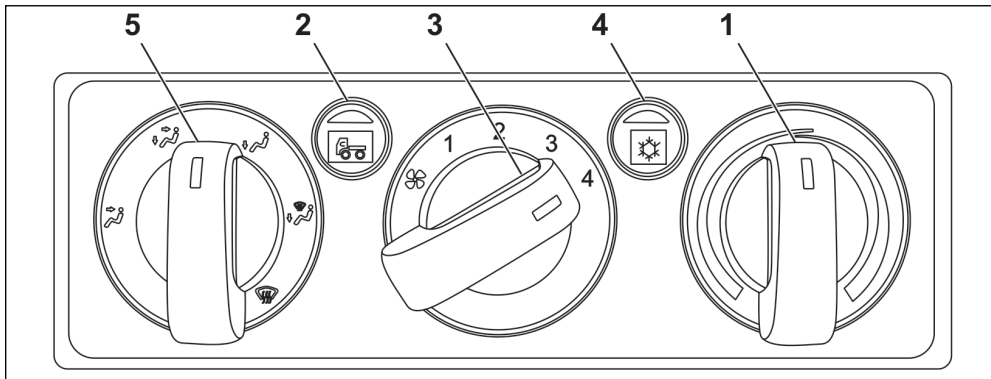

5. AIRCONDITIONING

Mechanical controlled only heater unit-RHD

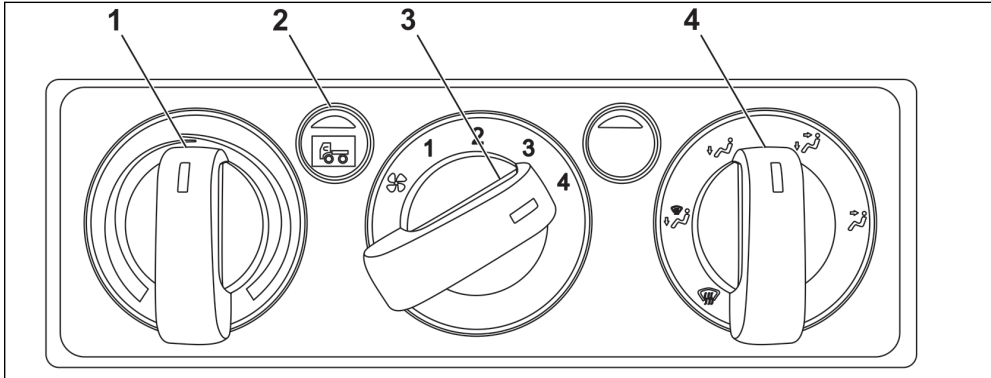

Mechanical controlled only heater unit-LHD

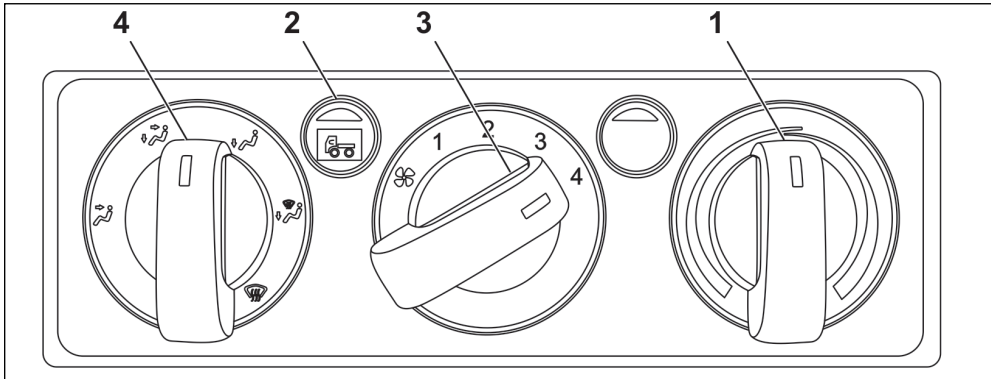

1. Temperature control knob
2. Fresh/recirculation switch
3. Blower knob
4. Mode knob

5. AIRCONDITIONING

Mechanical controlled only AC unit-RHD/LHD

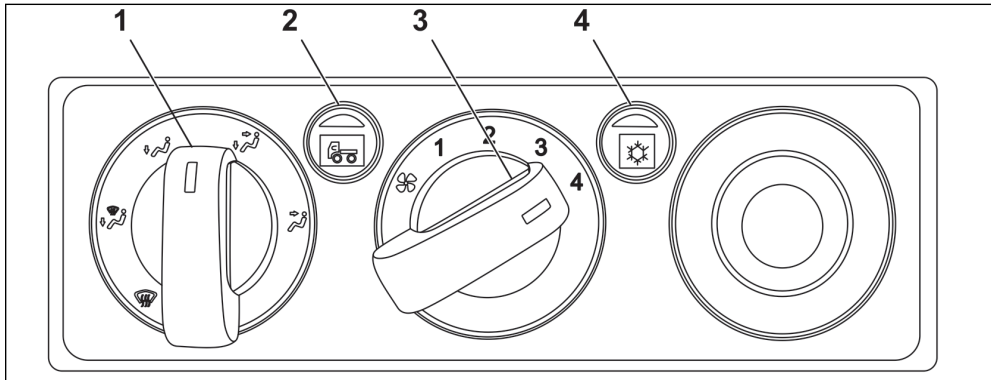

1. Mode knob
2. Fresh/recirculation switch
3. Blower knob
4. AC on Mode knob

5. AIRCONDITIONING

Mechanical controlled only vent-RHD/LHD

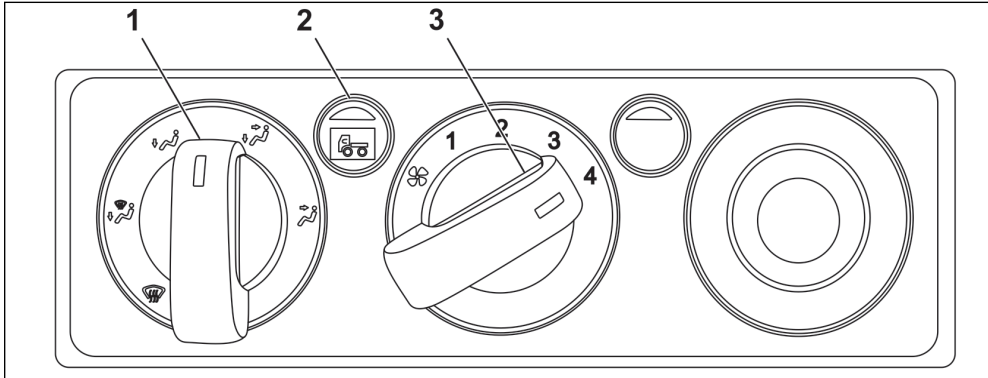

1. Mode knob
2. Fresh/recirculation switch
3. Blower knob

If the AC is not functioning properly contact nearest UD Trucks authorised dealer.

NOTE

Use Freon HFC134a to help protect the environment. Only use the specified refrigerant to charge the cooling system.

To protect the global environment, do not discharge refrigerant into the atmosphere.

6.DAILY INSPECTION

6.1 Areas to inspect

- It is important for the driver to be completely aware of the vehicle's condition on a day to day basis, to prevent accidents and malfunctions. For this reason, always conduct the daily (pre-driving) inspection once a day before driving the vehicle.
- Conduct the inspection in the following order to make sure that the daily (pre-driving) inspection is conducted in a proper way. The detailed inspection instructions are explained below.
- **The inspection items shown in bold are items that are conducted appropriately based on the vehicle's mileage, driving conditions, and other factors.**
- In addition, when trouble occurs, have the vehicle inspected and repaired at **UD Trucks** authorised dealer.

1. Have all the problems from the previous day been completely repaired?	
2. Vehicle exterior	<ul style="list-style-type: none"> • Are the tyres inflated to the proper air pressure? Also, are there any cracks, damage, or abnormal wear out? • Is the tyre tread groove depth enough? • Is the engine oil filled to the proper level? • Is the engine coolant filled to the proper level? • Has water condensation been removed from the air reservoir? • Is the window washer fluid filled to the proper level? • Has the water accumulated in primary fuel filter been removed from it? • Are the lights are they dirty or damaged? • Is the greasing of front spring pin and shackle pin is done for every 5000 km? • Is the greasing of rear spring pin and shackle pin is done for every 5000 km? • Is the wheel nuts are tightened to the specified torque?
3. Get into the cab	<ul style="list-style-type: none"> • Is the parking brake released properly? • Is the window washer fluid sprayed properly? • Does the wipers wipe properly?
4. Start the engine	<ul style="list-style-type: none"> • Does the engine start well? are there any abnormal sounds? • Does the engine run at idling speed and accelerate properly? • Does the air pressure as seen by the air pressure gauge rise well? • Is the air exhausting noise normal, when the brake valve (pedal) is pressed and released? • Do the lights and indicators illuminate and flash properly?
5. Drive the vehicle	<ul style="list-style-type: none"> • Do the brakes work well?

6.DAILY INSPECTION

6.2 Inspection instructions

Tyre inflation pressure, cracks, damage and abnormal wearing

DANGER

Driving without the correct air pressure will result in abnormal tyre wear, bursting of tyres and could lead to accidents.

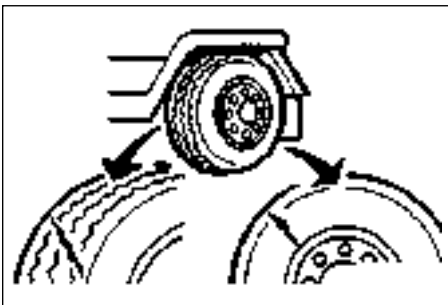

Inspect the tyres using a tyre pressure gauge to check if they are inflated to the proper air pressure. Also inspect the spare tyre. Always remember to put on the valve caps after inspection.

For setting the correct tyre pressure
Refer tyre manufacturer's recommendation

Tyre tread groove depth

WARNING

Driving with cracked, damaged, or worn out tyre could cause accident and result in personal injury.

WARNING

Do not drive with tyres that have a tread groove depth less than the usage limit. Failure to do so could cause slipping and hydroplaning at high speeds.

Tyre tread groove depth usage limit

Driving condition	Limit value
When driving on general roads	1.6 mm
When driving on highway	3.2 mm

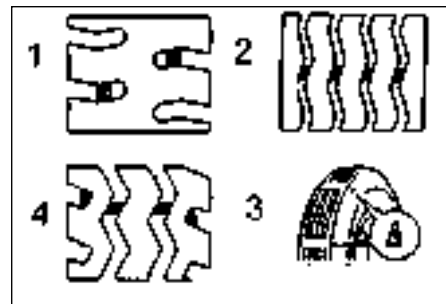

1. Lug pattern
2. Rib pattern
3. TWI (Tread Wear Indicator) mark on tyre
4. Rib/lug pattern

Inspect the tyre to make sure that it has enough tread. Replace the tyre if the tread groove depth is less than 1.6 mm. The tyres have 6 equally spaced locations (TWI positions) that indicate when the tread groove depth is less than 1.6 mm. Replace the tyres with new ones when the tyres have worn out and expose the marks.

Wheel end assembly inspection

Inspect the vehicle when it is parked on a level ground and the parking brake is applied, walk around the vehicle and visually inspect each wheel assembly for the following conditions:

- Loose, damaged or missing hubcaps.
- Oil leaks at hubcap for the front hub.
- Lubricant on the hub, or inside of wheel and tyre.
- Insufficient oil level and poor oil condition.

If any of the above conditions are found, the vehicle should be placed out of service until the item can be repaired by **UD Trucks** authorised dealer.

Engine oil level

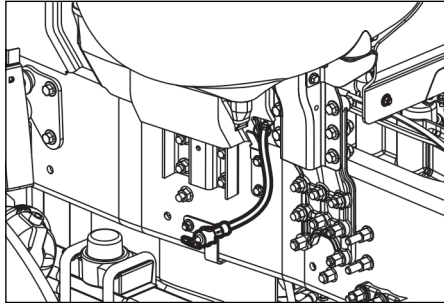

Pull out the dipstick, wipe out the oil from the gauge surface, re-insert the dipstick, remove it again, and check whether the oil level is between MAX and MIN.

Always maintain the oil level between the MAX and MIN mark of the dipstick.

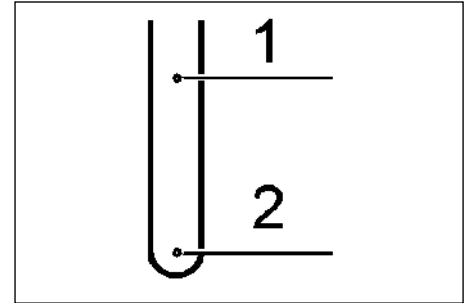

1. MAX
2. MIN

If the oil level is below MIN top up the engine oil as necessarily. **Refer Chapter 11 for Recommended lubricants and Capacity.**

NOTE

Always check the engine oil level when the engine is cooled.

6.DAILY INSPECTION

Coolant level

WARNING

Do not open the expansion tank cap when the engine is running. Failure to comply can result in burns due to high temperature steam or boiling coolant.

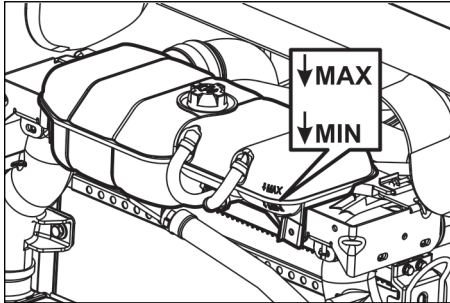

Open the front panel to check the engine coolant level, Check the coolant level only when the engine is cool. Check the coolant level in the expansion tank. The coolant level should be maintained between the MAX and MIN mark. If the coolant level is below the MIN line, add the UD coolant till the MAX line.

CAUTION

Continuing to drive with low coolant can cause engine overheating and could damage the engine function.

Draining water condensate from the air reservoir

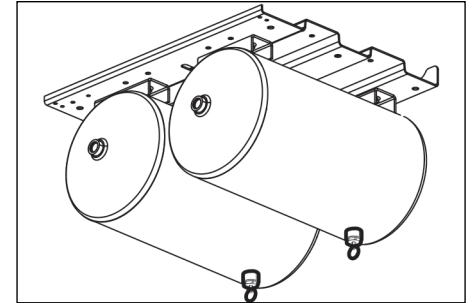

Open the air reservoir drain cock and drain the water collected. Make sure that the drain cock is closed completely after draining.

- If a large amount of water is drained out, there could be a problem with the air dryer, so have it inspected at **UD Trucks** authorised dealer immediately.

Parking brake lever tension

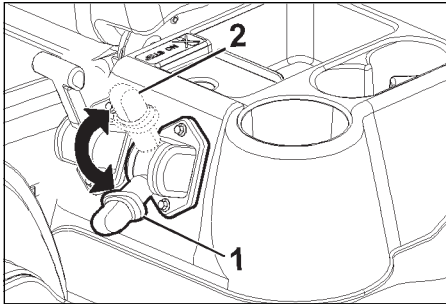

1. Parking brake released
2. Parking brake applied

Air-actuated type

- Pull the lever all the way to the park position and confirm that the sound of the air being exhausted is heard.
- Inspect to see if the lever is secured in the park position.

Windshield washer level and spray performance

WARNING

Do not use coolant as washer fluid. Doing so can greatly impair windshield visibility and can cause an accident.

CAUTION

Operating the windshield washer when the washer reservoir is empty can damage the motor. Always keep the washer tank filled with fluid to the specified level.

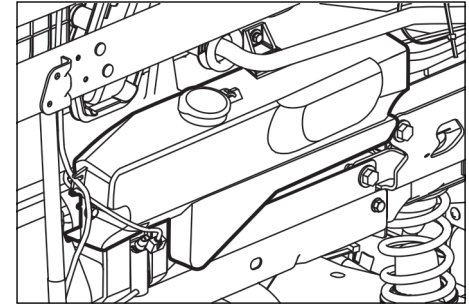

Open the front panel.

- Open the cap and check the washer reservoir fluid level.
- If it is low, add more washer fluid through the reservoir filler opening.

Check to see if the washer fluid sprays out normally. If it does not spray out normally, have it inspected and serviced at **UD Trucks** authorised dealer.

6.DAILY INSPECTION

NOTE

- **Do not replace the washer fluid with soap water or any alternate fluids. Doing so can cause blotches and freeze the fluid.**
- **Do not operate the wipers when the windshield is dry. Doing so can only lead the wipers to scratch the glass.**
- **To prevent damage to the wiper blades, do not use the wipers when the windshield is frozen.**

Wind-shield washer fluid

- Always use **UD** windshield washer fluid. The wind-shield washer fluid is mixed with water when used. If the concentration is not adjusted to match the temperature and usage conditions, it could freeze and will not spray from the washer jets and damage the motor.
- As a guideline, in normal conditions, 3.5 parts water is mixed with 1 part of **UD** windshield washer fluid. In winter use 2 parts water. When the temperature drops to -20°C use 1 part of water. When oil due to smog is stuck to the windshield, use 1.5 parts water.

Engine starting performance and abnormal sounds

Check if the engine starts quickly and runs smoothly.

- Check if there are any abnormal sounds when the engine is started or when it is idling.

Engine performance when running at low speed and when accelerating

With the engine warmed up, check if it continues to run smoothly while idling. Also, see the tachometer to check if the engine idles in the specified range, **Refer, “Engine specification” in Chapter 11.**

- Gradually accelerate the engine and check if the accelerator pedal moves without sticking and if the engine runs smoothly without knocking

Air charging performance

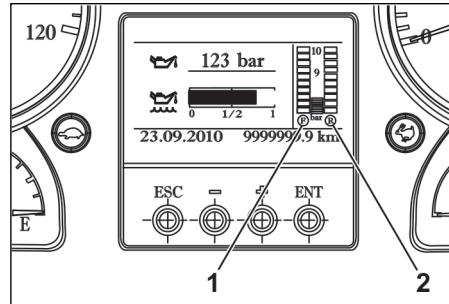

- Air pressure, front brake
- Air pressure, rear brake

Use the air pressure gauge to check the air pressure increase. It is normal if the time taken for the indicator in the display raises similar to value in the table.

If it does not raise normally, there could be a leak in the air system or other issues. Contact an authorised **UD Trucks** authorised dealer immediately.

Standard time	Engine speed (Idling)	Air pressure
Under 12 min.	600 rpm	0 → 804 kPa {0 → 8.04 bar}

- Check if the air pressure shown in the air pressure gauge is normal. It is normal if the display indicator is in the range as shown in the following table.

Pneumatic system pressure	770-930 kPa {7.9 - 9.5 kgf/cm ² }
---------------------------	-------------------------------------------------

NOTE

If air reservoir is filled with a pressure of 0 kPa {0 bar}, the gauge indicator in display will not move for a while after the engine is started. Also at times the two indicators will not start moving at the same time. This is not gauge malfunction. This happens because there is a pressure regulation valve between the air compressor and the brake air reservoir.

6.DAILY INSPECTION

Brake valve operation

WARNING

Keep the area around the pedals clean. Empty cans and gravels could wedge into the pedal and interfere with braking operation leading to accidents.

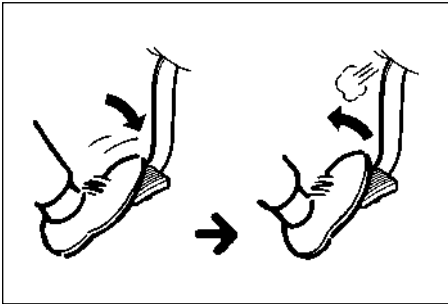

The brake valve operation is normal if the pedal does not stuck abnormally when pressed and when there is an air exhausting sound from beneath the floor when the pedal is released. The brake pedal should return to its original position when released.

Light operation

- Turn on each light switch and check to see if the light glows or flashes. The turn indicators are normal if they flash 60 to 120 times per minute. Check the light lenses and reflectors are free from dirt and damage.

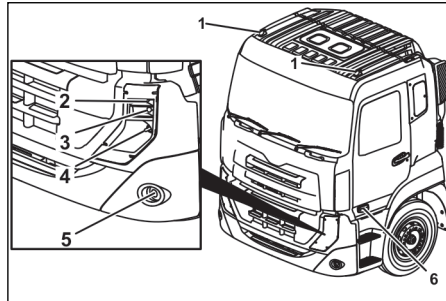

1. Front end outline marker lamp
2. Front position lamp
3. Front direction indicator
4. Head lamp
5. front fog lamp
6. Side direction indicator.

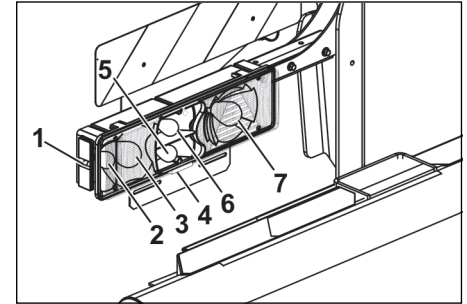

1. Side marker lamp
2. Rear end outline marker lamp
3. Rear fog lamp
4. Rear registration lamp
5. Reversing light
6. Rear direction indicator
7. Rear position and stop lamp.

7.CORRECT DRIVING OPERATION

7.1 Correct driving operation

Before starting the engine

- Check the area around the vehicle to make sure that there are no people or obstacles in the vicinity.
- Make sure that the parking brake is applied.
- Adjust the driver's seat and steering wheel so that all switches and pedals can be operated easily.
- Adjust the mirrors so that the driver can see clearly the front and rear side of the vehicle.
- Fasten the seat belt correctly.

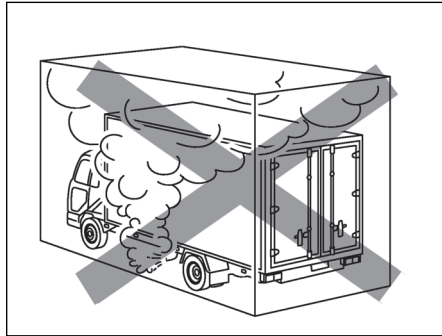

WARNING

Do not place loose objects such as tools, cans, bottles, mats, etc on the cabin floor. They can roll underneath the pedals and prevent their effective operation could lead to accidents.

Starting the engine

WARNING

Start the vehicle only after seated comfortably in the driver seat, with the seat belts fastened.

CAUTION

If the engine does not start, crank the engine at an interval of 30 seconds. If the engine fails to start after three cranks, contact UD Trucks authorised dealer for assistance.

7.CORRECT DRIVING OPERATION

Apply parking brake.

1. Shift the gearshift lever to neutral position.
2. Confirm that the **auxiliary brake switch** is moved to the **OFF** position (if equipped).
3. Turn the ignition switch to **ON** position. Wait for 3 seconds to initialize all meters on instrument cluster before moving to **START** position.
4. To start the engine, press the clutch and brake pedals fully. Then turn the ignition switch to the “**START**” position.

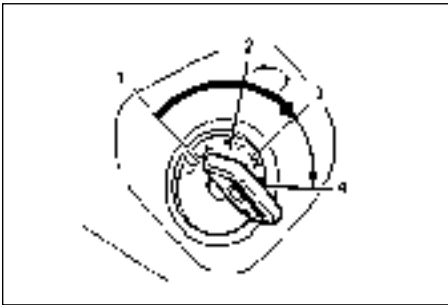

1. LOCK
2. ACC
3. ON
4. START

Stopping the engine

NOTE

Allow the engine to idle for a short period of 30 seconds before stopping it.

Turn the ignition switch from ON (3) position to the ACC (2) position, to stop the engine.

⚠ CAUTION

If the engine does not stop even though the ignition switch has been returned to the ACC position, move the vehicle to the nearest place free from traffic, switch on the hazard lamp and contact the nearest UD Trucks authorised dealer to address this issue.

7.2 Operation precautions

Handling a new vehicle

- The service life and performance of a truck depend largely on how it is handled during the initial break-in period. To extend the service life and to assure top performance of the vehicle, observe the following recommendations.

Start-off precautions

- Avoid sudden starting or stopping. Sudden starting not only causes the clutch to wear out fast but also causes premature and abnormal wear out of tyre and brake linings.
- Avoid half clutching as much as possible. Half clutching is one of the major causes of clutch damage. In addition, driving with resting the foot on the clutch pedal could easily create a half clutching situation, so ensure not to place the foot on the clutch pedal while driving.

Precautions while driving



Driving with the engine off is dangerous and ensure that it is not done. Compressed air will not be supplied to the brakes when the engine is off, which will cause the brakes not to work. The steering assist mechanism also will not work. So it will be difficult to steer the vehicle.

It is normal for the warning lights to be off while driving. If a warning light illuminates or a warning buzzer sounds, it means that there is a problem. Stop the vehicle in a safe place and take the required measures.

- Decelerate before entering curves. Braking while turning the steering wheel will cause the wheels to lock up and the tyres to

slip. This will not only result in wear out of tyres, but could cause them to lose their grip on slippery roads (wet, icy, or snowy roads). It is advised to avoid doing this as much as possible.

- **Ensure care to maintain enough space with the next vehicle when turning at an intersection.** The rear tyres will turn at a smaller radius than the front tyres and could hit the nearby vehicle or pedestrians. Ensure care while turning the vehicle by using the outside rear view mirrors, in case of poor visibility look through the window to make sure that the sides of the vehicle are safe. The out side rear view mirrors should be positioned properly to view blind spots around the vehicle making it easy and safe when turning.

7.CORRECT DRIVING OPERATION

When traveling downhill or shifting down

DANGER

Do not engage the auxiliary brake when the road is slippery (due to snow, water, etc.) Failure to comply can lead the rear wheels to lock up and cause the vehicle to skid causing accident.

When traveling downhill, use the same gears that were used when traveling up the hill but in combination with the auxiliary brake to ensure safe driving. If the vehicle still generates too much speed, use the foot brake and maintain a safe speed at all times.

- Do not drive downhill with the transmission in neutral position.
- Ensure care to avoid engine overrun when driving downhill.
- The tachometer's red zone shows the overrun speed range, ensure that the indicator does not enter the red zone.

Operating precaution engine rpm

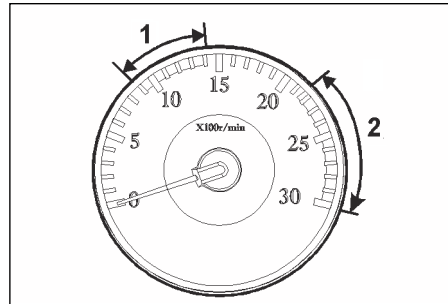

1. Green zone - 900 to 1450 rpm
2. Red zone - 2150 and above

Always maintain the engine rpm in green zone while driving. When the engine rpm exceeds the allowable maximum rpm, the warning message display will turn on and the overrun warning buzzer sounds to warn the driver. In this case, reduce engine speed.

Engine overrun

CAUTION

Overrun is when the engine is running at a speed that exceeds the engine's maximum rpm. Do not exceed the maximum allowable rpm. Driving beyond this range overstresses the engine components and could cause the engine to malfunction.

Brakes

WARNING

Avoid continuously using the foot brake for a long period of time. The brake drums or linings could overheat and reduce the braking effect.

CAUTION

When driving the vehicle after washing or while driving through deep puddles, the braking effect could be greatly reduced by water getting on the brakes.

When braking, always do so in combination with the auxiliary brakes. The vehicle is equipped with auxiliary brakes. Disengaging the clutch and shifting the shift lever to neutral position will prevent the auxiliary brakes from working, which will reduce the braking force and lengthen the stopping distance. Wait until just before the vehicle stops to disengage the clutch. Using the auxiliary brakes will lengthen the life of the brake linings.

- Before descending down steep roads or long downhill roads, check the brakes ahead of time to make sure that they are working correctly. Then, always use the

auxiliary brake to maintain a safe speed at all times. Shifting down to avoid overrunning the engine will also increase the braking force of the auxiliary brake. Using the foot brake too much will cause the brake drum and brake linings to overheat, which will decrease the braking effect.

- If the driver feels that something is wrong with the brake while driving, immediately stop the vehicle in a safe location and inspect them.

CAUTION

Do not brake sharply except in emergencies. Sharp braking causes the tyres, brake drums and brake linings to wear out prematurely and will reduce the life span of other parts.

7.CORRECT DRIVING OPERATION

Brake pedal operation method

- Follow the directions below to smoothly stop the vehicle.
- Press the pedal about 1/3 to 1/2 the way 25 to 35 meters in front of the planned stopping place.
- At about 5 to 6 meters in front of the planned stopping place, gradually allow the pedal to return (about 1/3 to 1/2 of the initial pressed amount).
- Press the pedal only slightly just before the planned stopping place to stop the vehicle.

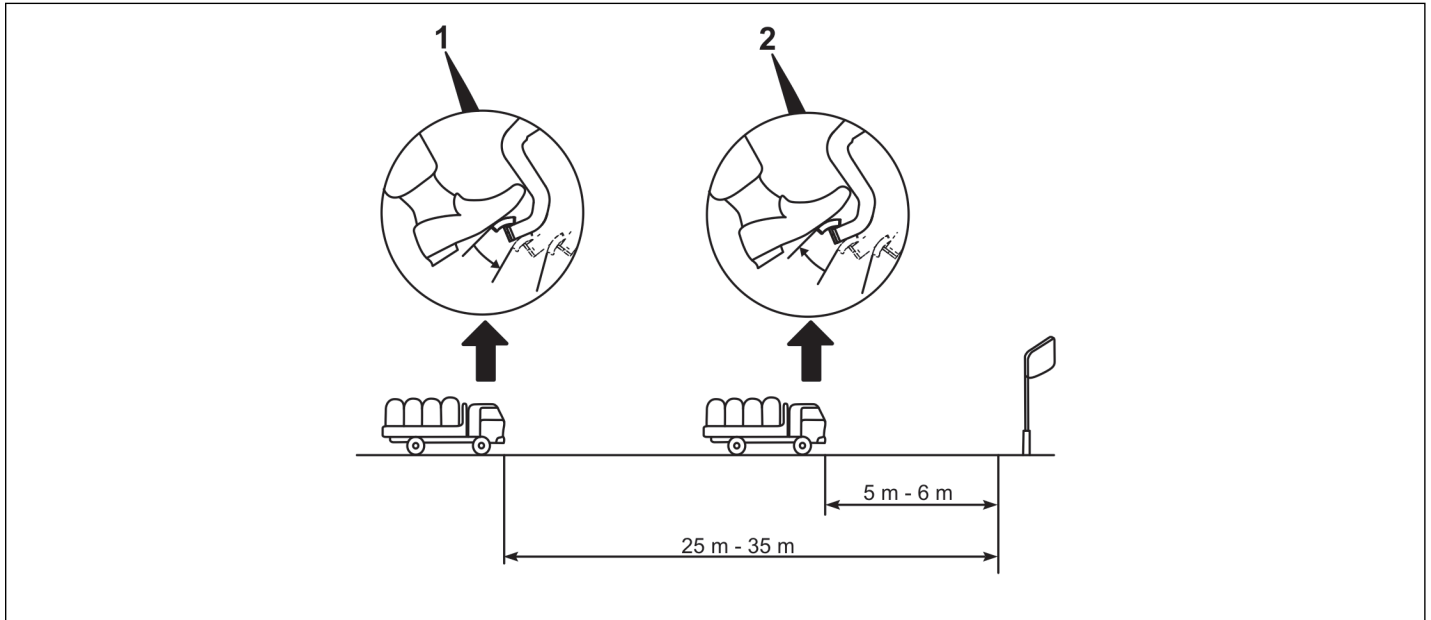

1. 1/2 to 1/3 of total stroke

2. 1/2 to 1/3 of the amount that the pedal is pressed



WARNING

The brakes will stop working when the compressed air in the brake system is below the operating pressure. Always check the air pressure gauge indicator and maintain the operating air pressure.



WARNING

- Keeping the pedal pressed will stop the vehicle in a short distance, but this will be accompanied by a strong shock.
- Avoid releasing the brake pedal fully when allowing it to return. The air in the air chamber will be exhausted and the vehicle will continue to roll forward. This could result in an accident.
- Avoid abrupt usage of the pedal up and down, this will exhaust the air chamber and the vehicle will keep rolling forward.

7.CORRECT DRIVING OPERATION

Precautions when driving ABS vehicles

WARNING

The ABS braking system cannot prevent accidents resulting from carelessness, poor judgment while driving. ABS aids effective braking to maintain vehicle control during braking, not quicker braking. Stopping distance will be longer on surfaces which are wet, slippery, snowy, rough, with gravel or if tyre chains are used. Always maintain a safe distance from the vehicle in front. The driver or user is responsible for safety of self, vehicle and road.

The **ABS** is a device that improves safety by appropriately controlling wheel slip during braking to utilize the friction between the tyres and the road surface. But, it is not a device that makes extreme driving possible above safety limits. Observe the following safety precautions and always make an effort to drive safely.

- When the ignition switch is turned ON, confirm the **ABS** warning light illuminates and then turns off after about 3 seconds.
- When the **ABS** operates, an operating noise may be heard intermittently. This is not a malfunction.
- When driving on slippery roads, the braking distance will be longer than during normal driving on dry, paved roads even when the **ABS** is operating. In addition, **ABS** equipped vehicles may take longer braking distance on snow covered, gravel roads than the vehicles not equipped with **ABS**. Always drive at a safe speed and sufficient inter-vehicular distance

taking the road and tyre conditions into consideration.

- The **ABS** is designed to prevent the wheels from slipping when braking and will not operate when the wheels slip during acceleration or when turning. In addition, when driving on a slippery roads, such as on icy roads, driver might lose control of the vehicle and have trouble steering it even when the **ABS** operates. Always drive at a safe speed and avoid sharp braking and sharp steering as much as possible.
- When driving on icy and other slippery roads, changing the transmission into a low gear and using the auxiliary brake while driving could cause the drive wheels to lock up and the vehicle to become unstable. In this case, disengage the clutch and apply the brakes.
- The wheels could slip when using the auxiliary brakes (exhaust brake) while driving on slippery roads or over bumps. This could

7.CORRECT DRIVING OPERATION

cause the auxiliary brakes to temporarily release and their respective indicator lights to go off, but this is a normal operation of the **ABS** and is not a malfunction. Try to drive carefully taking into consideration the road conditions, the inter-vehicular distance, and other factors.

- For any questions, please consult an authorised **UD Trucks** authorised dealer in advance.

Trailer brake

Available only in vehicle equipped with trailer connections.

WARNING

Do not use trailer brake as a parking brake.

The trailer brake valve acts only on the service brakes of the semi-trailer. Such brakes are independent of the parking brakes and service brakes in the tractor vehicle.

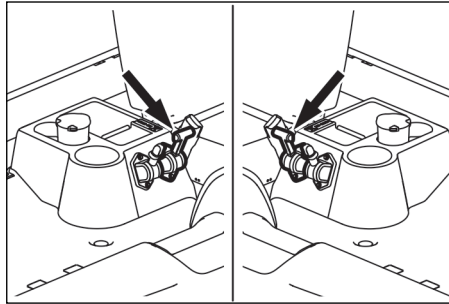

Their use on descents, particularly on surfaces with little traction, will ensure that the tractor and trailer remain aligned, preventing them from “jackknifing”.

WARNING

Always activate the semi-trailer brake before applying the service brake to prevent the tractor and trailer from jackknifing.

The semi-trailer brake must also be used when coupling the tractor vehicle to the semi-trailer. To do this, carry out the procedure below:

- Bring the truck close to the semi-trailer and connect the electric cable and the air hoses.
- If necessary, leave the engine running to fill the semi-trailer's air tank.
- Activate the semi-trailer brake valve.
- With the semi-trailer brake activated, reverse the truck carefully until coupling has occurred.
- Before moving the coupled vehicles, check that the trailer is correctly coupled and that the brakes and lights are working.

7.CORRECT DRIVING OPERATION

Gearshift lever operation

CAUTION

Do not apply excessive load to the gearshift lever.

When shifting gear be sure to press the clutch pedal fully. In addition make sure that the vehicle is fully stopped before shifting from forward to reverse or from reverse to forward.

When working with gearshift lever with shift switch (12 Speed) high range and low range shift must be done between 6th and 7th shift only.

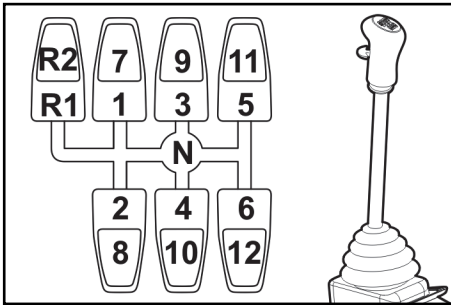

High range: R2, 7, 8, 9, 10, 11, 12
Low range: R1, 1, 2, 3, 4, 5, 6

NOTE

Make sure gearshift lever low indicator is illuminated when engaged in low range.

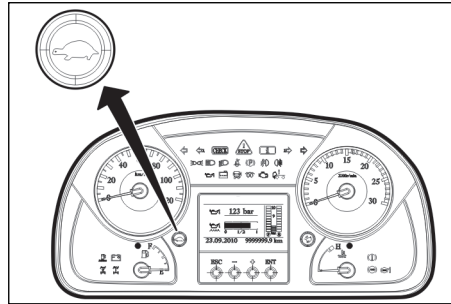

NOTE

Indicator will not illuminate, only buzzer will sound when gearshift lever moved to high range.

Clutch operation instructions and precautions

- Do not drive the vehicle when the clutch disc is worn out or when the clutch is having problems. In addition, observe the following to prevent clutch damage.
- Do not drive with resting the foot on clutch pedal.
- When stopping on an uphill road, avoid partially engaging clutch, to maintain the position of the vehicle.
- Avoid using the clutch except when necessary.
- Do not drive downhill with the clutch disengaged and the transmission in neutral position.

Steering wheel operation precautions

CAUTION

Do not hold the steering wheel turned all the way for more than 10 seconds. Doing so could damage the power steering unit.

When turning the steering wheel, the power steering hydraulic pressure change could create a sound that resembles a sound striking the hydraulic pipes, and is not a malfunction.

Inter-vehicular distance

WARNING

Please obey all local traffic rules and regulations.

There is a tendency to ignore the inter-vehicular distance when following another vehicle. But, make sure sufficient space is maintained between the vehicles to avoid any kind of accident.

- Generally, when driving under 60 km/h, the distance is half the number on the speedometer. But when driving faster than 60 km/h (excluding vehicles with speed limiter device), maintain an inter-vehicular distance greater than the number on the speedometer. For example, when driving at 40 km/h, maintain a space of 20 m or more. But when driving at 70 km/h (excluding vehicles with speed limiter device), maintain a distance of over 70 m. It is important to maintain an even greater distance when it is raining, to allow extra space for emergency stopping.

7.CORRECT DRIVING OPERATION

When handling freight, do not overload the vehicle



WARNING

Fasten down sheets and ropes. The heat from the silencer or exhaust pipe could cause sheets or ropes to catch fire while driving.









WARNING

Do not over load the vehicle. Over-loading will negatively affect steering and braking, which could lead to an accident.

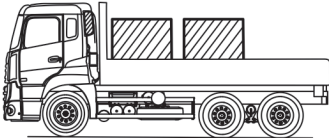
Overloading accelerates wearing out of the vehicle components and greatly shortens the useful life of the vehicle.

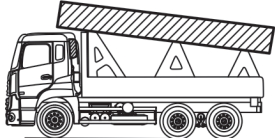
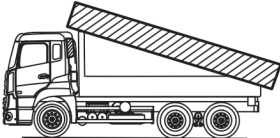
- If the load is unstable, it could fall over when braking or turning, so fasten it to the truck bed using braces and wires.

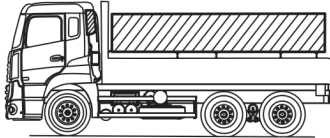
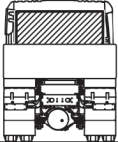
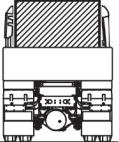
7.CORRECT DRIVING OPERATION

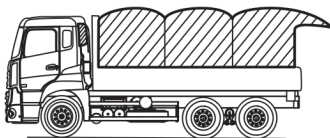
	Correct loading method	Incorrect loading method
Ensure that the freight load is distributed equally and not unbalanced to any one side.	 A side-view illustration of a truck with a flatbed. Two rectangular blocks of freight are stacked in the center of the bed, one behind the other, representing a balanced load.	 A side-view illustration of a truck with a flatbed. Two rectangular blocks of freight are stacked, but one is positioned significantly further towards the rear of the bed than the other, representing an unbalanced load.
When loading long objects, keep them from extending outside the body as much as possible, use a rack and support the load evenly.	 A side-view illustration of a truck with a flatbed. A long, thin rectangular object is loaded on the bed. It is supported by a triangular wooden dunnage block in the center, preventing it from extending beyond the front and rear of the truck body.	 A side-view illustration of a truck with a flatbed. A long, thin rectangular object is loaded on the bed, extending significantly beyond the front and rear of the truck body without any support.
When using racks under the freight, ensure care to position them correctly so that the freight is equally supported.	 A side-view illustration of a truck with a flatbed. A large rectangular load is secured with a net. Two wooden racks are positioned under the load, one towards the front and one towards the rear, to provide even support.	 A side-view illustration of a truck with a flatbed. A large rectangular load is secured with a net. Two wooden racks are positioned under the load, but they are not centered, leading to uneven support.
Highly stacked freight could fall over when turning, Do not stack the freight more than the recommend height.	 A rear-view illustration of a truck. The freight is stacked in a single layer, with a height that is safe for transport.	 A rear-view illustration of a truck. The freight is stacked in multiple layers, reaching a height that is excessive and unsafe.
Make sure that ropes and sheets are tight and secure. Secure heavy freight to the truck bed.	 A side-view illustration of a truck with a flatbed. A large rectangular load is covered with a sheet. The sheet is secured with ropes that are pulled tight and anchored to the truck bed, ensuring the load is stable.	 A side-view illustration of a truck with a flatbed. A large rectangular load is covered with a sheet. The sheet is not secured properly, and one corner is loose and hanging off the side of the truck.

7.CORRECT DRIVING OPERATION

Cargo loading



WARNING

When parking the vehicle to load or unload along / on the road place a warning triangle appropriately to warn the upcoming traffic.

The various methods involved in loading the cargo plays a vital role in driving performance of the vehicle. Load the cargo in an uniform manner allowing the load to be distributed evenly.

Energy efficient driving

The conditions that improve fuel efficiency depends on the engine, transmission specifications and also on the cab deflectors installed. Driving technique and vehicle maintenance however, also has a large impact on fuel efficiency. Refer to the following points and perform “fuel efficient driving”.

Driving techniques for improving fuel efficiency

Drive at an economic speed

The best possible performance and fuel economy will be obtained if the engine speed is maintained at all time within the “Economy” zone. This is indicated by the green band in the tachometer provided in the instrument panel. It is advisable to always operate the vehicle within this green band

Idling for long time causes fuel wastage.

Do not run the engine in idling for more than 2 minutes.

Sudden starting and quick accelerations will affect fuel economy.

Avoid sudden start off or quick accelerating with the accelerator pedal completely pressed, this increases acceleration resistance and consumes more fuel.

Inertial driving improves fuel economy

Fuel is not consumed when the auxiliary brake is being used. Use slow inertial driving by using the auxiliary brake when driving downhill or before stopping at a traffic signal.

Early shift upon and late down shift

Increasing the engine speed consumes more fuel. in order to keep the engine speed low, use high gear shift as possible.

Wave driving

Repeated acceleration and deceleration of vehicle in an abnormal manner greatly decreases fuel economy. Avoid drastic change in speed.

Reduce the start-off and stopping frequency

Start-off acceleration requires energy to get the stationary vehicle moving, so the engine is at nearly a full load and much fuel is consumed. Drive carefully before signals to reduce the vehicle start-off and stopping frequency.

Stacking the freight.

Do not load the freight too high or in an uneven manner or haphazardly. Such stacking increases air resistance and greatly decreases fuel economy.

Vehicle maintenance for good fuel efficiency

Maintain correct air pressure

If the tyre air pressure is low, it will increase the rolling resistance and decrease the fuel economy.

Do not drive with the air cleaner clogged.

Driving with the air filter clogged increases the air intake resistance and decreases power, decreasing the fuel economy.

Drive in sweet spot explained in fuel coaching system

Operate the engine in sweet spot explained in fuel coaching system. ***Refer “Fuel coaching system” in Chapter 3.***

7.CORRECT DRIVING OPERATION

7.3 Driving under special conditions

Driving on poor roads

Drive in a low gear and maintain constant speed when driving on muddy or gravel roads.

Driving when it is raining

- Avoid sudden braking during rain, it may cause slipping.
- Driving through water in puddles will decrease the braking performance.
- The brake performance will return to normal after the brakes are applied 2 or 3 times.
- When driving through a fog, turn on the fog lights and drive carefully.

Driving through snow

- When driving through snowy or on icy roads, attach tyre chains and drive at a low speed.
- Snowy and icy roads are dangerous because they are easy to slip. Avoid sharp steering, sudden braking and ensure care while driving.

Tyre chain mounting



WARNING

- **Check the tyre air pressure after securing with the chains. The tyres could be damaged if they are not inflated to the proper air pressure.**
- **Always use tyre chains that match the tyre size.**
- **When using double tyres, use triple chains because they are safer.**
- **If the tyre chains are not secured correctly, they could become loose or come out while driving and interfere with other vehicle components. Make sure chains are secured correctly.**

NOTE

- Do not attach tyre chains to the front wheels. Always attach suitable tyre chains to the rear wheels.
- There are various types of tyre chains. Please consult nearest UD Trucks authorised dealer for advice when purchasing tyre chains.

Attach chains on the tyres, when driving through snow or on icy roads.

- Secure the tyre with chains so that they are not loose. Check them for looseness after driving for 5 to 10 minutes. Always keep in mind that the tyres are mounted with chains.

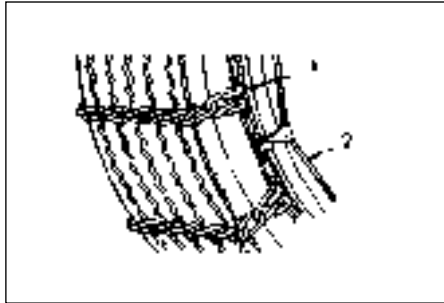

- Attach the tyre chains so that the bends of the tyre chain connectors (1) are facing away from the tyre and with the chain bands (2) attached securely. Tie down any excess chain with wire to keep it from hitting the fender.

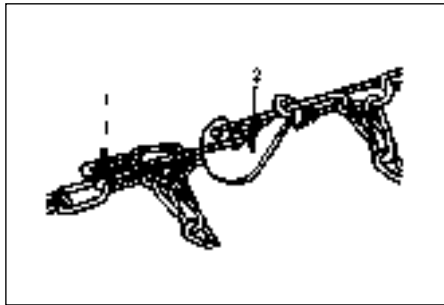

1. Wire

2. Hook

Fuel tank

⚠ DANGER

Fuel leaks could cause a fire. If there is a fuel leak, contact the nearest UD Trucks authorised dealer for assistance.

⚠ WARNING

Always use good quality fuel.

- Always keep the fuel tank filled to the maximum level to avoid corrosion in the fuel system.
- Always tighten the fuel tank cap to avoid entry of dust, water and snow into the tank.

When parking

When parking for a long time in cold areas, choose a place where the vehicle will be out of snow fall. If an appropriate place is not available, park the vehicle so that the wind will not strike the engine compartment.

THIS PAGE HAS BEEN LEFT
BLANK INTENTIONALLY

8.INSPECTION AND MAINTENANCE

8.1 Inspection and maintenance

Regular inspection and maintenance can extend the service life of the vehicle and contribute to safe and comfortable driving. This section describes simple methods of maintenance that can be performed by customers. For detailed inspections and maintenance, or parts that cannot be serviced by the user, contact the nearest **UD Trucks** authorised dealer.

When performing inspections and service, pay attention to the following items:

- Select a safe location.
- Maintain safe working conditions.
- Use appropriate tools.
- Stop the engine before inspection.
- Engage the parking brake lever to the park position.
- Make sure that wheels are secured with wheel chocks, to avoid vehicle movement.

- The jack provided below the driver seat should be used only for changing the tyre.

Cab tilting

CAUTION

Always keep open the front panel before tilting the cab to avoid damage to the vehicle.

1. Park the vehicle on a level surface.
2. Apply the parking brake.
3. Switch OFF the engine.
4. Make sure there is sufficient space in front and above the cab.
5. Make sure that there are no loose objects which could fall forward and cause damage.
6. Close the doors.
7. Chock all the wheels.

8. Open the front panel.

NOTE

The cab tilting wrench is placed inside the front panel.

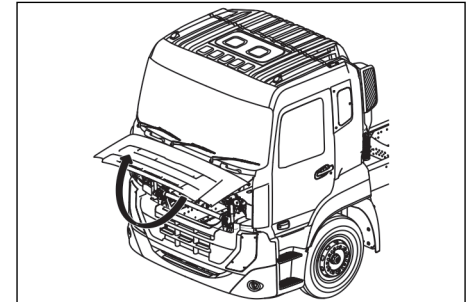

8.INSPECTION AND MAINTENANCE

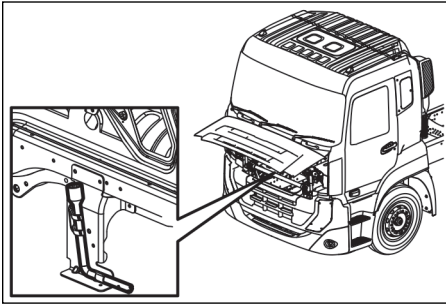

WARNING

- The vehicle should be on a flat surface, when the cab is tilted.
- Make sure that there is sufficient space while tilting the cab.
- Make sure that there are no loose, heavy objects in the cab which could fall forward and cause damage.
- Do not stand in front or behind the cab while tilting.
- Make sure that the gearshift lever is in neutral position before tilting the cab.
- The cab should be tilted completely.

9. Turn the selector valve clock wise.

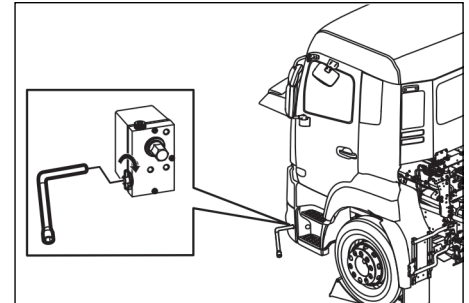

For construction vehicle the selector valve is located in the footrest area, refer below image.

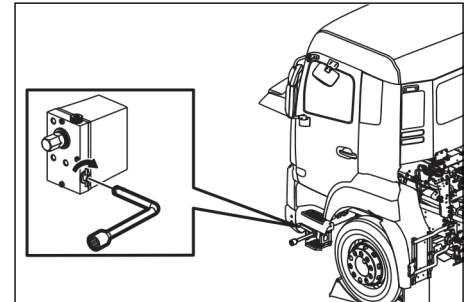

8.INSPECTION AND MAINTENANCE

10. Use the wrench supplied along with the extension bar and pump until the cab is fully tilted.

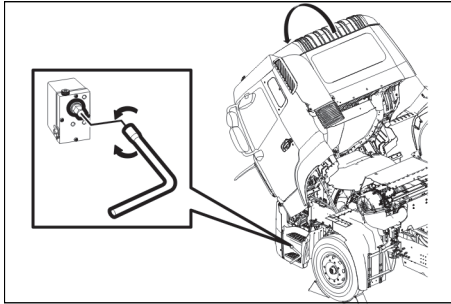

For construction vehicles the tilt knob is located inside bumper, refer below image.

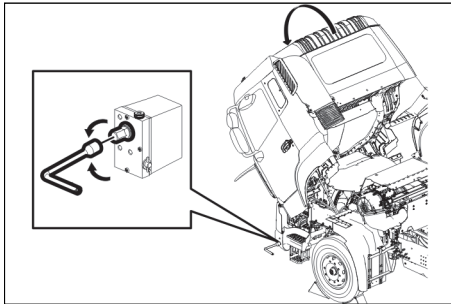

Cab lowering

1. Turn the selector valve in anticlockwise direction.
2. Use the wrench supplied along with the extension bar and pump until the cab is tilted back to its lowered position.

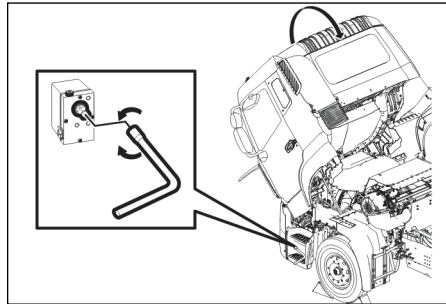

For construction vehicle the tilt knob is located inside the bumper.

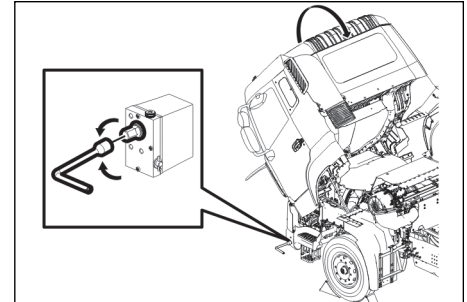

8.INSPECTION AND MAINTENANCE

8.2 Air cleaner

Inspection and replacement

The air cleaner filter is of maintenance free type and cleaning is not necessary. The vehicle may be equipped with either of the two air cleaners.

Air cleaner 1st stage

Air cleaner 1st stage with safety element

The vehicle is indicated with an icon display in the instrument cluster, which informs the driver about the clogged air filter.

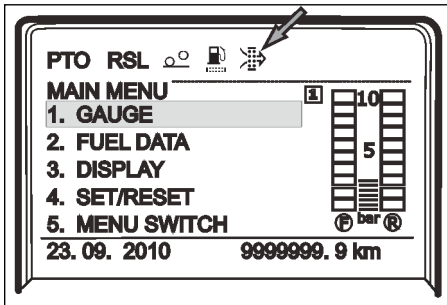

Evacuator valve

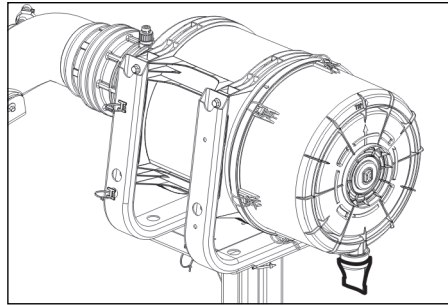

Evacuator valve is an important part of the functionality of the air cleaner. It is an integral part of the pre-cleaning stage on air cleaner. Perform visual check and squeeze to make sure the valve is flexible and not inverted. Also check whether it is damaged or plugged.

CAUTION

Do not clean the air cleaner filter. Always replace the air cleaner filter.

Inspection and maintenance of air cleaner

Inspection and replacement procedures: Air cleaner primary filter

CAUTION

Make sure that there is sufficient space in front and above (min 1 meter) of the vehicle before tilting the cab. Failure to do so will lead to damage in cab.

1. To access the air cleaner, tilt the cab. **Refer “Cab tilting” in Chapter 8.**

8.INSPECTION AND MAINTENANCE

2. Unlock the air cleaner cover clips and remove the cover.

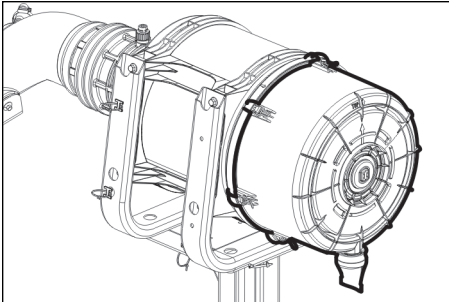

3. Remove the air cleaner primary filter.

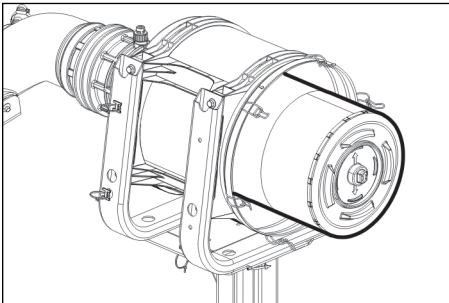

CAUTION

Take extra care while cleaning the air filter housing. Dust particles may enter the engine air inlet and can cause damage or premature wear of piston and liners.

4. Clean the cover and inside of the air cleaner housing with a clean dry cloth.

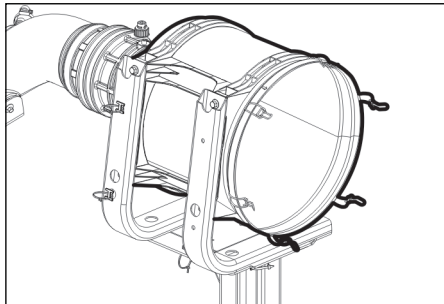

NOTE

Make sure that the engine air inlet is blocked in a proper way to avoid entry of dust particles.

5. Clean the evacuator valve. Make sure that it is not broken or damaged.

NOTE

If the evacuator valve is broken or missing, water and dirt can easily enter the air cleaner. Install a new evacuator valve.

6. Check the air cleaner inlet hose for breakage and loose clamps. If broken, replace it with a new part. If the clamps are loose, tighten them.
7. Replace the air cleaner primary filter.

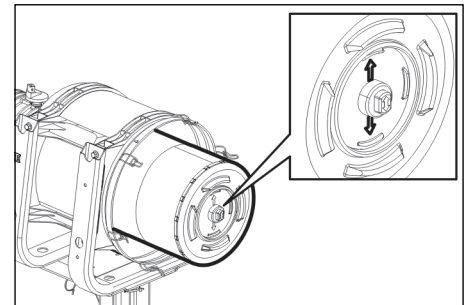

8.INSPECTION AND MAINTENANCE

NOTE

Make sure that the arrow mark on the air cleaner filter is vertical.

NOTE

It is recommended to use UD air cleaner filter. Do not use an inferior filter.

8. Install the air cleaner housing cover and secure with the clips.

⚠ CAUTION

If the clips are not fully installed, it can cause defect in the filter packing surface and allows dust into the engine. This will in-turn cause premature wear of pistons and liners.

9. Lower the cab to the original position. *Refer “Cab lowering” in Chapter 8.*

Air cleaner: Secondary filter replacement

1. Tilt the cab. *Refer “Cab tilting” in Chapter 8.*
2. Unlock the air cleaner cover clips and remove the cover.

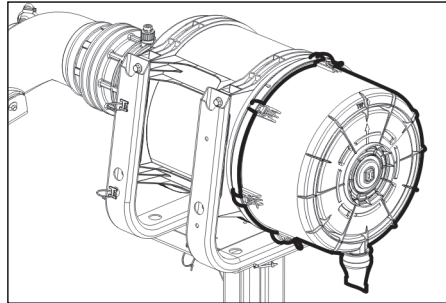

3. Remove the air cleaner primary filter.

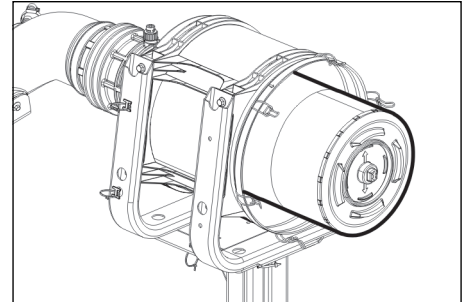

NOTE

Replace air cleaner secondary filter after every third primary filter replacement.

NOTE

Make sure that the engine air inlet is blocked in a proper way to avoid dust particle entry.

8.INSPECTION AND MAINTENANCE

4. Remove secondary filter.

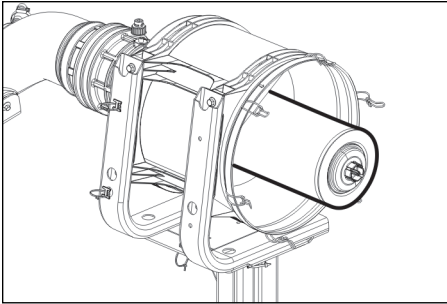

5. Install the secondary filter.

6. Install the primary air cleaner filter.

NOTE

Make sure that the arrow mark on the air cleaner filter is in vertical portion.

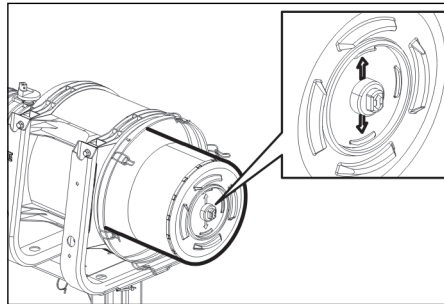

7. Install the air cleaner cover back in place and secure it with the clips.

8. Lower the cab. **Refer “Cab lowering” in Chapter 8.**

Handling precautions for air cleaner

- The dust ejector orientation should be within $\pm 15^\circ$ range from the vertical line shown in the below image. This is to ensure the dust is ejected properly from the air cleaner.

8.INSPECTION AND MAINTENANCE

- Make sure that the cover and the air cleaner filter are installed in an accurate manner. If not correctly installed, suction of dust into the cylinder may cause a malfunction.
- Do not touch the filter paper of the air cleaner filter with hand or any tools. Do not allow lubricants to come in contact with the filter paper.

Air-conditioning filter-nylon mesh

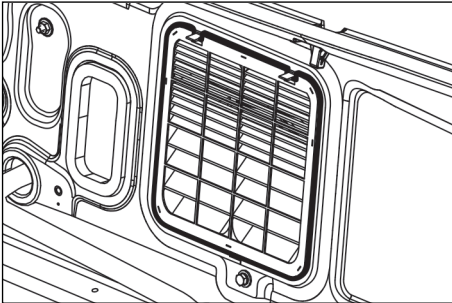

A nylon mesh filter, filters the incoming air. This mesh filter is accessible behind the front panel.

Air conditioner belt tension

⚠ DANGER

Do not check or adjust drive belt unless engine is switched OFF and the transmission is in neutral.

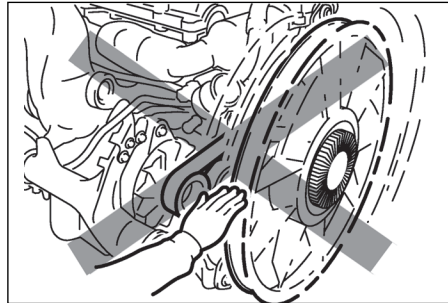

- Check that none of the grooves in the belt is missing.
- Check that the belts are not cracked. Cracked belts must be replaced.
- There must not be any dirt or grease on the belts or the contact surfaces of the belt pulley.
- Check the automatic belt tensioner.

To inspect the compressor belt tension

Push down the belt between the pulleys with a constant force. Check to see that the tension pulleys move with constant speed. Then release the belt and check to see that the tension pulleys return to the original position by means of the spring force.

Replace the belt tensioner when any of the following conditions exist..

- If the pulleys do not move when pushing down the belt.
- If there are any abnormalities in the pulley motion.
- If the pulleys do not return when releasing the belt.
- As per maintenance intervals.

8.3 Engine oil filter

Oil filter replacement-GH11E

The vehicle is equipped with a cartridge type oil filter.

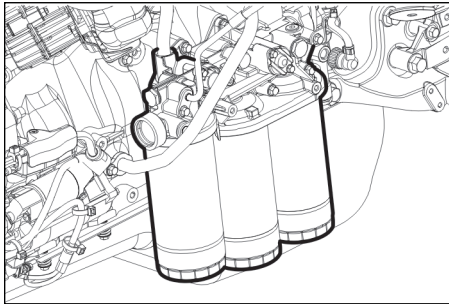

CAUTION

A blocked cartridge could cause unfiltered or contaminated oil to be supplied to the engine components or reduce the oil flow rate. This could adversely affect the life span of the engine. The filter must be replaced on regular intervals.

CAUTION

It is strongly recommended to use UD Genuine Parts. Using inferior oil and filter could diminish operation of the engine and emission controls.

Replacement procedure

WARNING

Just after driving, the engine oil will be hot and can cause burns when contacting the skin. Refill engine oil only when the engine is cold.

1. Before removing the drain plug, place an appropriate container under the engine and clean the drain plug. The drain plug (1) is located on the left-hand side of the sump. Remove the drain plug and drain the oil.

2. Tighten the drain plug. Tightening torque:
12.8 - 22.6 Nm (1.3 - 2.3 kgfm).
3. Replace the oil filter (2) and the bypass filter (3) at the same time as the oil is changed.

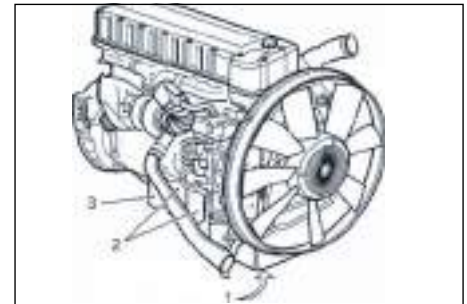

8.INSPECTION AND MAINTENANCE

8.4 Fuel filter

Inspection and replacement-GH11E engine

If fuel is contaminated with dust, it will affect the fuel system devices and reduce vehicle performance, this is checked by the fuel filter. If the “clogged fuel filter” warning is displayed, replace the fuel filter.

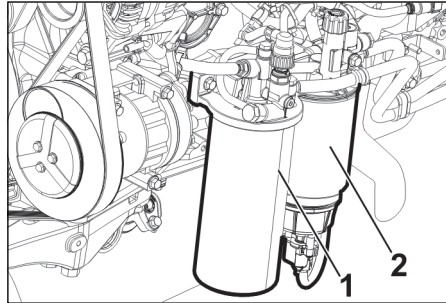
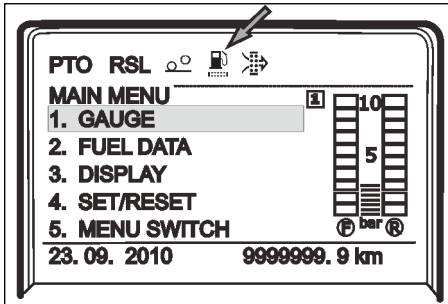

1. Fuel filter
2. Pre-fuel filter

Replace the fuel filter while changing the engine oil and filter. In addition, replace the fuel filter when the following occurs:

- Fuel pressure decreases.
- Engine output decreases.
- Clogged fuel filter warning and warning messages are displayed.

CAUTION

- If the fuel filter is clogged and left unattended, the cartridge will be damaged and contaminated fuel will flow directly to the injection pump and the nozzle. This adversely affects the life span of the engine. The cartridge must be replaced regularly even if the warning is not displayed.
- Depending on how the vehicle is used, the warning may be displayed even before the replacement time. In such a case, replace the cartridge. If the warning is often displayed even after the cartridge is replaced, contact the UD Trucks authorised dealer for inspection and maintenance.

8.INSPECTION AND MAINTENANCE

Replacement procedure and period

⚠ DANGER

Fuel leakage may cause fire. The filter must be firmly installed in order to prevent the leakage.

- 1 Clean around the filter bracket.

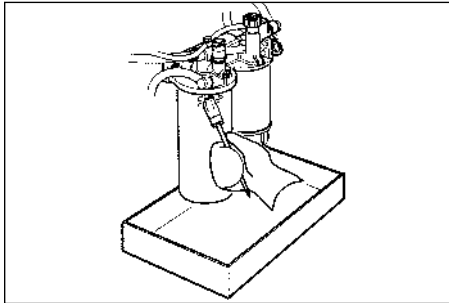

2. Place suitable container below the filter to collect fuel.

⚠ CAUTION

Do not allow the fuel to spill over and damage electrical components.

3. Loosen the fuel tank cap to release any pressure within the tank.
4. Remove the filter using a filter wrench.

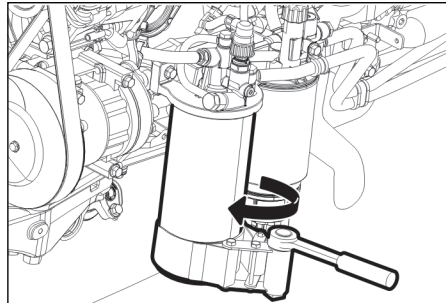

NOTE

The new fuel filter should be empty when replacing the fuel filter. Never fill the fuel in a new fuel filter before installing a fuel filter.

5. Lubricate the new filter gasket.
6. Screw on the filter manually using hand until the filter gasket comes

in contact with the housing surface.

7. Tighten the filter by additional half or three-quarter turn.
8. Replace the pre-fuel filter at the same time the fuel filter is replaced.
9. Disconnect the harness connector.

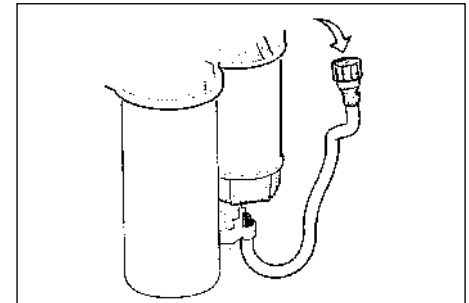

8.INSPECTION AND MAINTENANCE

10. Remove the pre-fuel filter using a filter wrench.

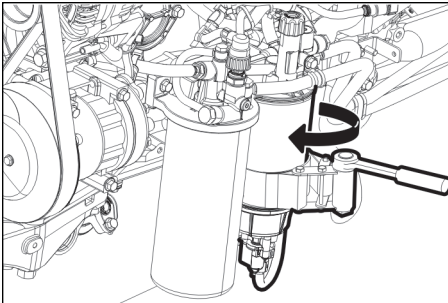

11. Clean the water level sensor that is installed in the plastic reservoir located under the pre-fuel filter.

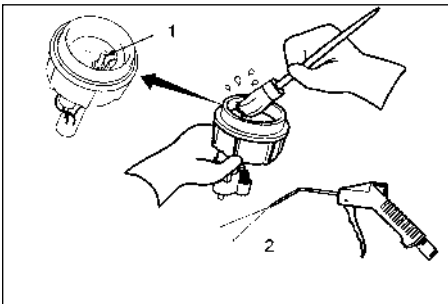

1. Level sensor
2. Air blow

NOTE

Deposits on the level sensor do not affect the function of the water separator, it is not required to replace the water separator.

12. The drain opening located at the bottom of the water level sensor does not clog.

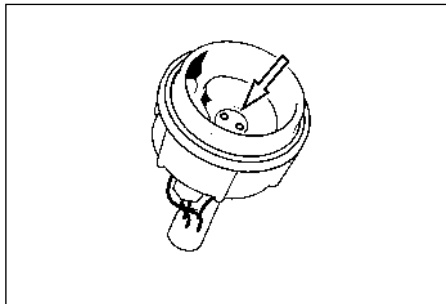

13. Attach a new seal, lubricate the seal and then install the plastic reservoir.

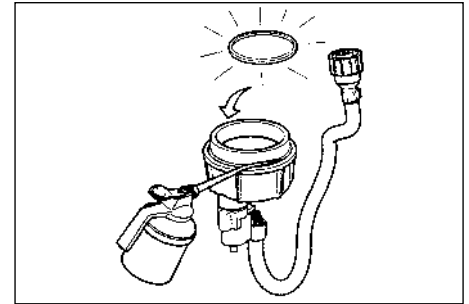

8.INSPECTION AND MAINTENANCE

14. Apply fuel to the pre-fuel filter top seal. Fill plastic reservoir/pre-fuel filter with clean diesel fuel and then install it in the same way as the fuel filter.

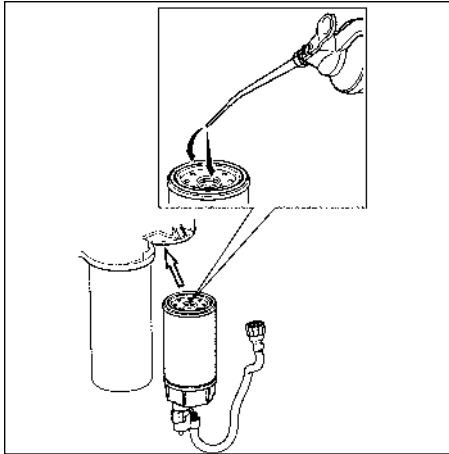

15. Apply fuel to the pre-fuel filter top seal. Fill plastic reservoir/pre-fuel filter with clean diesel fuel and then install it in the same way as the fuel filter.

16. Connect the harness connector.

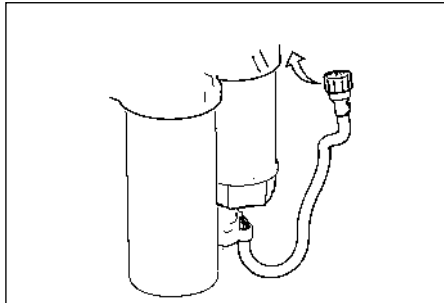

CAUTION

Do not reuse the fuel from the old filter into the new filter. Dirty fuel can damage the injector unit. Dispose the dirty fuel in an environmental friendly manner.

17. Start the engine and perform a leak check.

CAUTION

Check for fuel leakage. Fuel leakage may deteriorate the electronic parts.

18. Run the engine in idle condition for 3-5 minutes to remove air in the fuel system.

NOTE

The engine speed should not be increased as any air pockets can be forced into the cylinder head. This can result in stopping the engine.

8.INSPECTION AND MAINTENANCE

Water draining of fuel filter

When water gathers in the pre-fuel filter, a warning message and comments is displayed to warn the driver.

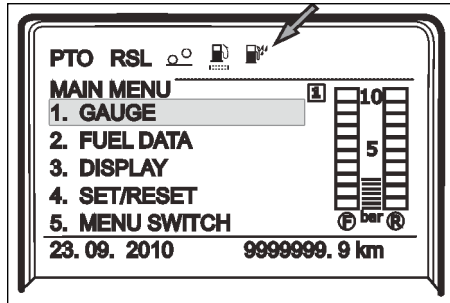

Stop the vehicle and drain the pre-fuel filter. If the warning symbol frequently recommends that the pre-fuel filter should be drained, then there is a problem with the fuel quality. Drain the fuel tank and refill with fuel of the correct quality.

CAUTION

Do not continue to drive the vehicle with the filter containing water warning message. Stop the vehicle and rectify it immediately.

Water draining procedure

WARNING

Always use a container to collect fuel for safety and floor cleanliness.

If fuel spills over any components of the engine, make sure that it is cleaned immediately and completely.

- 1 Stop the vehicle.

NOTE

If the engine is started before draining is complete, the process is interrupted.

2. Apply the parking brake.
3. Turn OFF the engine.
4. Remove the cover and noise absorbing materials attached on the left side rail (if equipped).
5. Place a container under the profile filter.
6. Turn the ignition key clockwise to the **ACC** position.
7. Select drain option from menu in instrument cluster display. The draining will continue for maximum 15 seconds or till the water is drained completely, whichever happens first.

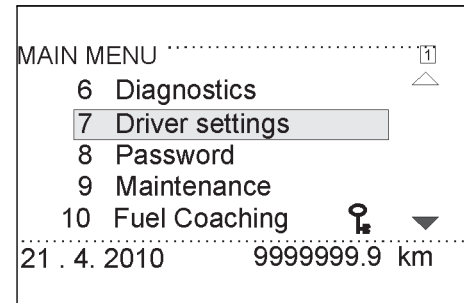

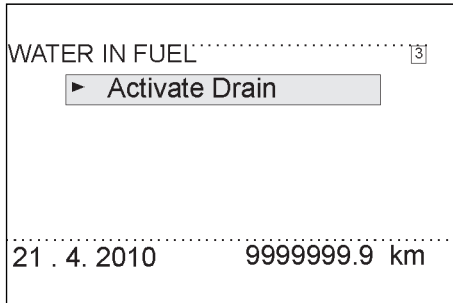
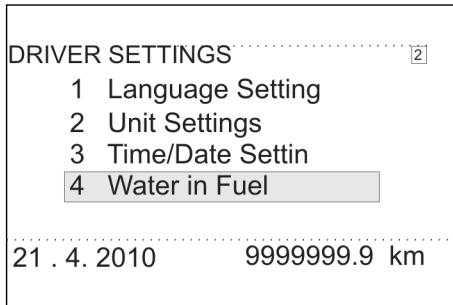

10. The warning status icon will disappear after the vehicle has started to run for some time after the draining operation.

NOTE

Once the draining operation is selected, it cannot be selected again for next 6 minutes.

8. Wait until the water has stopped draining.
9. Empty the container in a place where the contents will not cause environmental damage.

8.INSPECTION AND MAINTENANCE

8.5 Air bleeding of fuel system

The engine of this vehicle is provided with an automatic aeration system that automatically bleeds air from the fuel system and evacuates air to the fuel tank while the engine is running. Thus, during regular filter replacement, no manual air bleeding is required.

Air bleeding procedure

1. Stop the vehicle.
2. Apply the parking brake.
3. Turn OFF the engine.
4. Tilt the cab.
5. Remove the cover and noise absorbing materials attached on the left side rail (if equipped).
6. Pump the priming pump that is attached to the pre-fuel filter (2) bracket about 100 times until the pressure is felt in the priming pump (1).
Air bleeding will be completed, do not open the nipple.

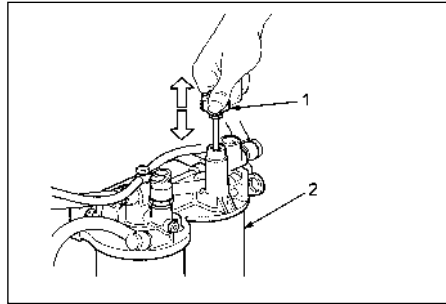

1. Priming pump
2. Pre-fuel filter

7. Start the engine. Let the engine run at low idle condition for about 3-5 minutes.

NOTE

Do not increase the engine speed, air may be pressed into the cylinder head.

8. If the engine does not start, perform air bleeding again.
9. Run the engine at idle speed.
10. Check for any leakage.

11. Ensure that the engine operation is smooth.
12. Install the cover and noise absorbing materials (if equipped).

⚠ DANGER

After starting the engine, check for fuel leakages from any components of the fuel system. If found stop the engine and contact the nearest UD Trucks authorised dealer since fuel leakages can lead to fire.

8.6 Battery

Battery maintenance

DANGER

Battery produces hydrogen gas, which is explosive. If the battery cables are connected incorrectly, a spark could start is sufficient to cause an explosion, causing injury to people and damage to the vehicle. The battery contains sulphuric acid which could cause serious burns. If the acid reaches the eyes, skin or clothes, wash them in abundant water and seek the immediate attention of doctor.

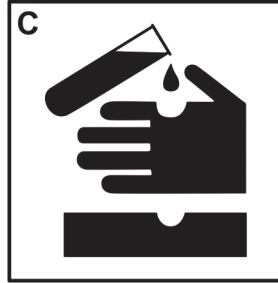

As batteries contain corrosive, toxic acid, **UD Trucks** do not recommend that they be handled by driver. Doing so might put the driver, third parties or the environment at risk. This procedure must therefore be carried out by a **UD Trucks** authorised dealer.

8.INSPECTION AND MAINTENANCE

8.7 Tyres

Rotation of tyre positions

Tyres at each wheel are worn depending on road conditions, cargo, brake and steering operation, If the spare tyre is not used for a long time, it may be deformed. To maintain even wear of tyres and to extend the life of tyres, tyre rotation is recommended. Applicable for both LHD and RHD.

Tyre rotation recommendation: Refer respective tyre manufacturer's service/owners manual

Tyre rotation for new tyres of same size and tread

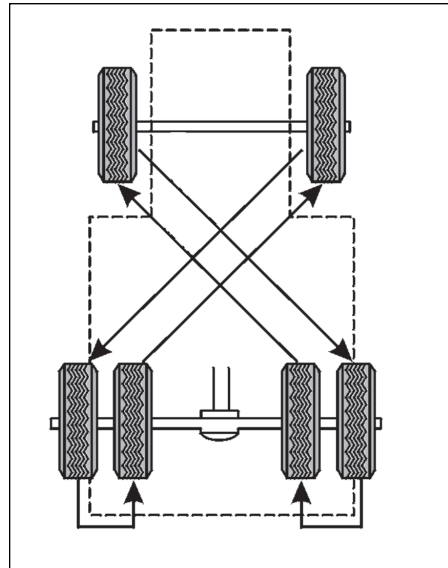

8.INSPECTION AND MAINTENANCE

Rotation pattern for vehicles equipped with Steer (RIB) pattern on front axle and drive (LUG) pattern on Rear axles

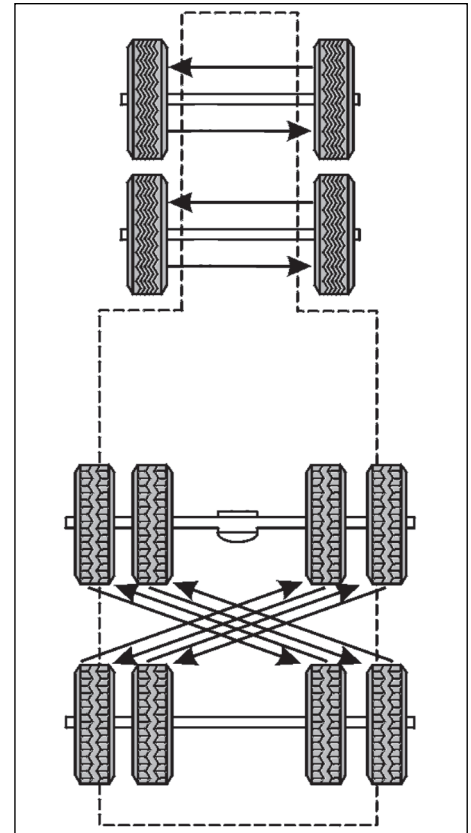
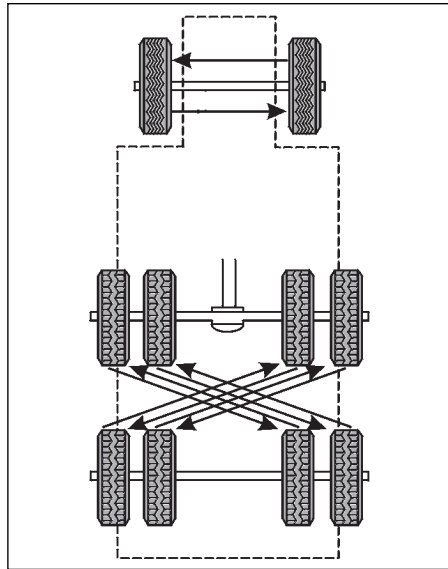
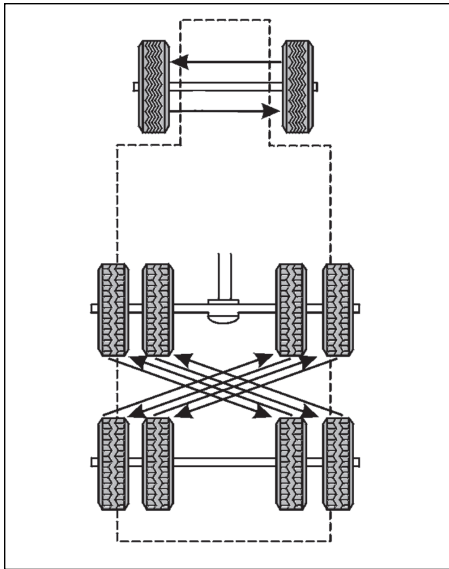

8.INSPECTION AND MAINTENANCE

Recommended tyre rotation for trailers - "wheel carriage".

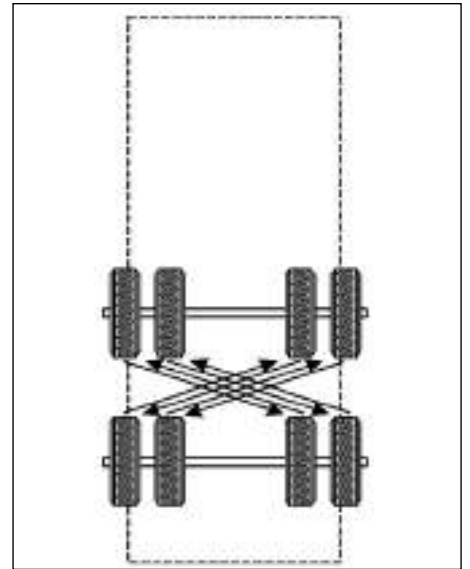
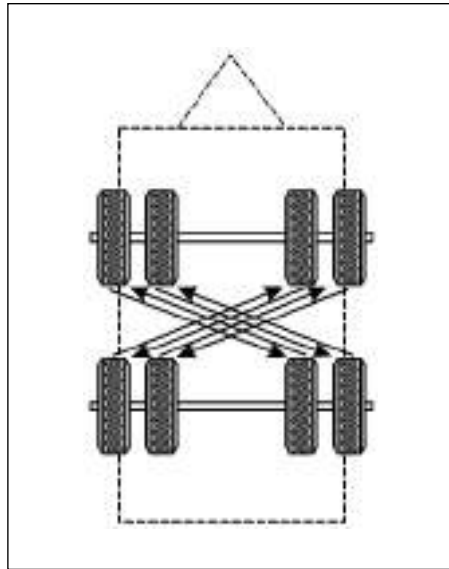
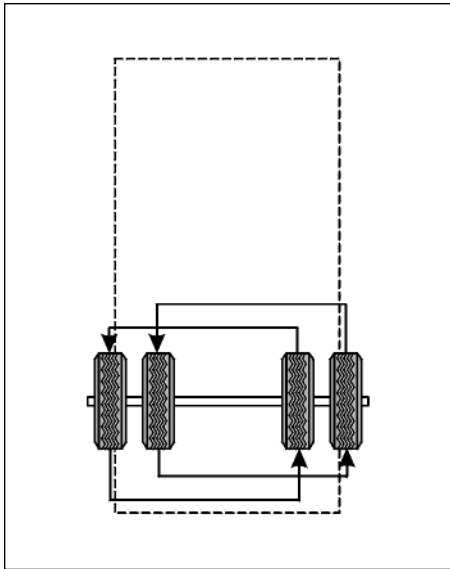

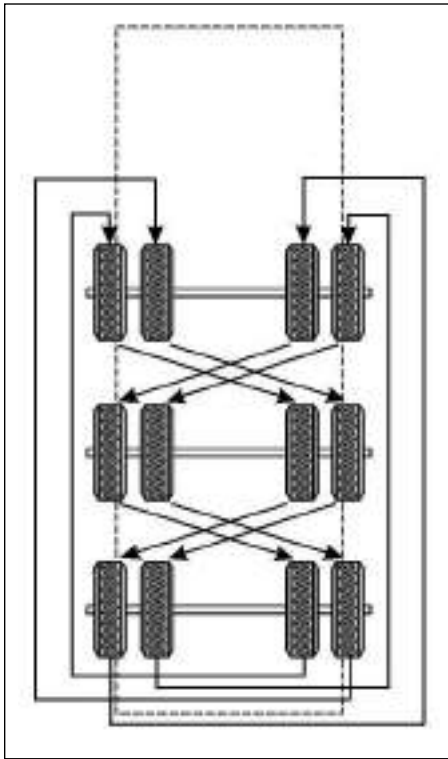

Precaution for tyre position rotation

Do not install tyres with the difference of outer diameters beyond the specified range at multiple wheels (rear wheels).

Bias tyre

Specified range of outer diameter difference for multiple tyres

Within 12 mm

- Replenish new tyres in pairs and install them on the front wheels first.
 - When new tyres are installed, perform a break-in drive. Perform break-in drive for 200 km or more at the speed of 60 km/h or less or for 300 km at the speed of 50 km/h or less. Check the air pressure after the vehicle has been driven for 3,000 km.
 - Check for galling deformation on the screw portion of the bolts and wheel nuts. If excessive damage is found, replace the deformed bolts and nuts as a set. Replace all bolts and wheel nuts as a precautionary measure because other bolts and wheel nuts may also attain damage.
- Use less worn tyres with adjusted wheel balance at front wheels.
 - Make sure that the turning direction is opposite to the previous installation.
 - Remember to install the same size tyre on the same axle. If tyres with different sizes are used on the same axle, the vehicle may be pulled either right or left. When braking or the steering wheel may be turned. Do not install tyres of different sizes.

8.INSPECTION AND MAINTENANCE

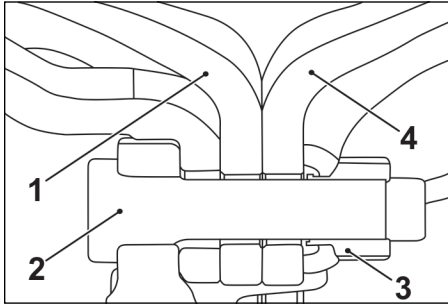

1. Inner disc wheel
2. Bolt
3. Wheel nut
4. Outer disc wheel

During tyre rotation, when the additional painting surface (e.g. colored body on the wheel flat area) comes in contact with the mating part (hub wheel), peel off the paint of the contact surface (flat area). Clean the surface with a wire brush and install tyres.

- Check the disc wheel. If crack is found, replace it.
- Install double tyres so that the air valves of the inner tyre and the outer tyre are diagonal in position.

Inspection- Wheel nut, hub bolt, and disc wheel

- When replacing a tyre, check for any malfunction in the wheel nut, hub bolt and disc wheel. If found replace with a new.
- Check that no cracks or damage is found, the bolt is not extended, and that there is no severe corrosion. In addition, check that the screw portion is free from wear out, collapse or galling.

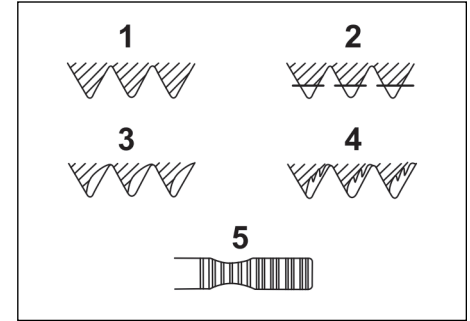

1. Normal
2. Collapse
3. Wear
4. Galling
5. Extension

- If a hub bolt is broken, the whole set of hub bolts and the wheel nuts of the wheel should be replaced. Contact the nearest **UD Trucks** authorised dealer.

Check loosening of wheel nuts, Inspection procedures

CAUTION

When the hub, disc wheel and wheel nuts are changed, be sure to check for loosening after driving about 50 to 100 km.

Tightening torque: 650 ± 75 Nm

- Tighten the wheel nuts to the specified tightening torque.

DANGER

If any crack or damage is observed on the wheel, it shall be attended immediately. Driving with a damaged wheel disc can lead to consequential damage and affect the safety of the passengers.

Removal of tyre

- Loosen the nuts with a wheel nut wrench. Loosen the nuts to the degree that they can be turned by hand.
- For the jack-up point and the jack-up procedures, **Refer “Jack up” in Chapter 8** Jack up the vehicle until the tyre is lifted a little.
- Remove the wheel nuts, and then remove the wheel.

Front wheel

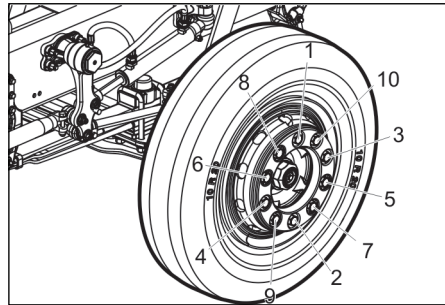

Rear wheel

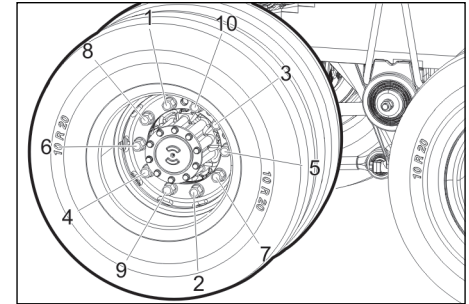

CAUTION

When loosening the wheel nuts before jacking up the vehicle and lifting the wheel off the ground, do not loosen the wheel nuts excessively. The wheel nuts shall be loosened as per the pattern described in tightening the wheel nuts. The wheel assembly is heavy and care should be taken while disassembly.

8.INSPECTION AND MAINTENANCE

Tyre Installation

Using tyre lever, attach the wheel disc by aligning it's bolt holes with the hub bolts.

Position the wheels so that the hub bolts are in middle of bolt hole and then pre tighten the wheel nuts.

Loosen the jack and lower the tyres slowly. Tighten the wheel nuts diagonally 3 times per nut and finally tighten the wheel nuts to the specified torque.

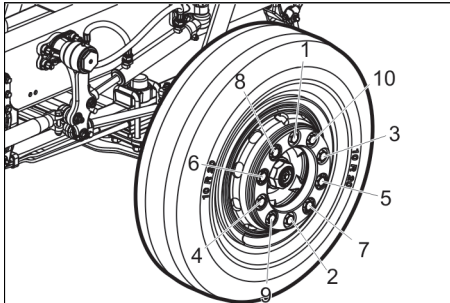

Pre tighten torque value:**250-350 Nm**
Final torque value: **650 ± 75 Nm**

Handling spare wheel carrier

To mount and remove a spare wheel, insert a crank handle into the socket of the tyre carrier and turn the crank handle by hand.

NOTE

Make sure that the nuts and studs are clean before handling the spare wheel.

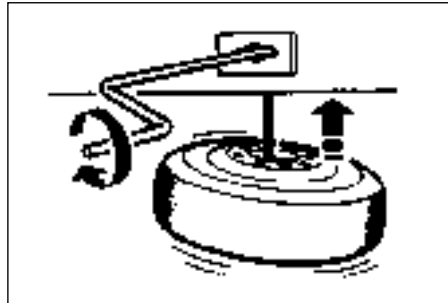

When a spare wheel is lifted, fit the carrier lifting plate (2) tab with the disc wheel in the correct place. Be sure to mount the tyre with the convex side of the disc wheel facing

upward. When the tyre is lifted with the rope twisted, the rope may be loose during driving. Make sure that the rope (1) is not twisted. Turn the crank handle to the right (clockwise) for lifting.

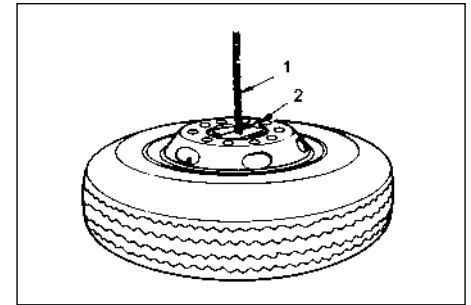

- The seating of tyre or disc maybe inaccurate if there is deformation in bracket or the flatness of contact surface is poor. It can also happen when cushion material falls off or clearance between cushion materials is more. Even if tightening is complete, it may become loose during driving. In this case, have the issue repair the problem at an **UD Trucks** authorised dealer before use.

- After lifting, fix the tyre by tightening with the crank handle. Apply a force of more than **294 Nm {30 kgf}** at handle edge for tightening. The guideline is the degree of turning the handle using one hand with the full force of a normal adult.
- After tightening, do not turn the crank handle in reverse direction and remove it.
- To remove the tyre, turn the crank handle to the direction opposite to when winding up until the ropes loosens.

WARNING

- When mounting a wheel/tyre, face the convex side of the disc wheel upward. Mounting with the concave side upward is unstable, and the tyre will loosen.**
- Ensure that the lifting plate is correctly fitted on the disc wheel (risk of the wheel falling).**
- After mounting the tyre, try to move it by hand to check that it is securely fixed. If it is not fixed, it could fall during driving (risk of accident). Mount the spare tyre securely.**

Wheel end assembly

Front wheel bearing uses oil as lubricant. Always fill the **UD** lubricant 0.3 Liter of GL-5 oil is to be used.

CAUTION

Failure to fill and maintain the correct quantity and quality of oil will lead to premature failure.

Wheel studs

Replace all the wheel studs that have damaged or distorted threads, are broken or bent, or are badly corroded. Also, replace both studs adjacent to the damaged stud. If two or more studs have damage, replace all the studs in the hub. Broken studs are usually an indication of excessive or inadequate wheel nut torque.

8.INSPECTION AND MAINTENANCE

DANGER

Mismatched or incorrect thread fasteners can result in thread stripping and/or assembly weakness leading to vehicle damage, malfunction or possible serious injury.

Inner and outer seal

Whenever hub assembly is disassembled replace the seal. Use proper tool to avoid distorting of seal. Lubricate the inner diameter of the seal with a light film of the same lubricant used in the hub.

CAUTION

Failure to lubricate the inner diameter of the seal, and the seal journal, may result in premature seal failure.

Hub cap O-ring-front hubs

The hubcap O-ring helps prevent moisture from entering the hub. A cracked or torn O-ring will allow moisture to pass through internal part of the hub, which can shorten the life of the hub. Therefore, the hubcap O-ring should be replaced if found damaged.

NOTE

A new hubcap O-ring must be installed whenever the hubcap is removed.

8.8 Jack up

Jack up points

Front wheel

- Placing the jack under the front axle.

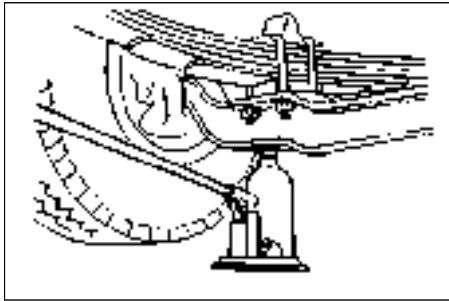

Rear wheel

- Placing the jack under the axle.

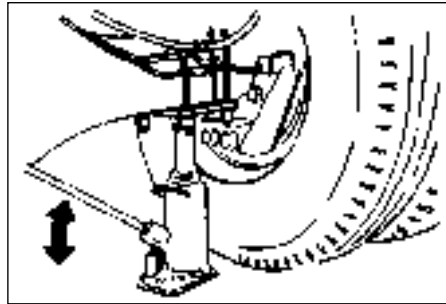

Jack up procedures

WARNING

- Do not start the engine while the vehicle is jacked up. The jack will dislocate due to engine vibration.
- Do not get underneath the vehicle while it is jacked up. If the jack is dislocated, it is very dangerous.
- Do not load or unload cargo during jack-up. Vibration or movement of the gravity center may dislocate the jack.
- When the jack is lowered, do not open the release valve suddenly.
- Use a wood block as wide as possible to ensure stability.

8.INSPECTION AND MAINTENANCE

CAUTION

- While the vehicle is jacked up, do not leave passengers in the cabin.
- Wipe out lubricant from the jack completely before jack-up.
- During jack-up, make sure that the jack is securely engaged with the jack-up point before lifting tyres.
- During jack-up for a long time, support the vehicle with a block or square piece of wood for safety.

NOTE

- Use only the jack (specified part) equipped on the vehicle.
- Use the jack when the ambient temperature is from -20°C to 70°C .

If jack-up is performed on the road due to flat tyre, select a safe location where traffic is not disturbed. Alert subsequent vehicles by using the hazard light or the stop indicator.

Jack-up

- To jack up wheels for replacement of a tyre, park the vehicle on flat and hard ground. Apply the parking brake securely. Place wheel chocks at the front and rear of the wheel that is diagonally positioned to the wheel for jack-up.

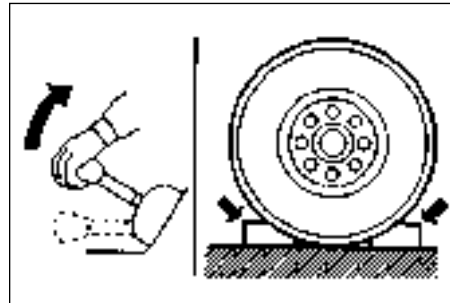

- Place the jack under the jack-up point and set it securely by turning the auxiliary screw.

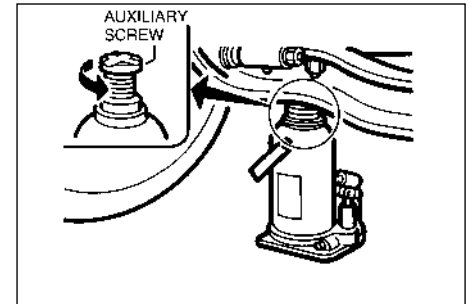

- Use the jack handle to close the release valve of the jack.

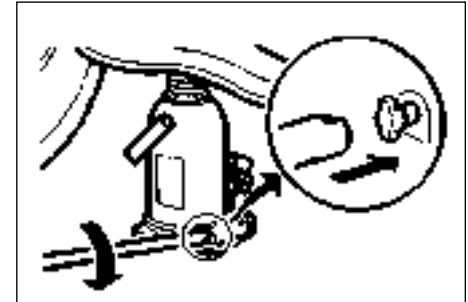

- Set the jack handle and move it up and down for jack-up

8.INSPECTION AND MAINTENANCE

Change of a tyre -Standard wheel

CAUTION

- Do not damage the hub bolt when removing or installing the wheels.
- If the tyre size or brand needs to be changed, contact the nearest UD Trucks authorised dealer.

NOTE

For changing the tyres of vehicle with ABS, ensure to switch OFF the ignition first.

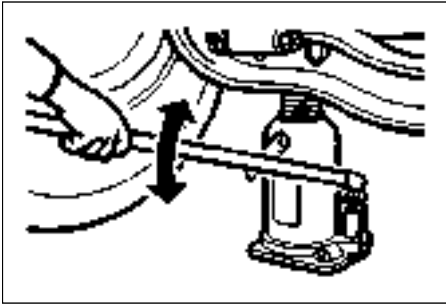

- To lower the jack, turn the release valve gradually to the left for opening with the jack handle. Lower the jack slowly

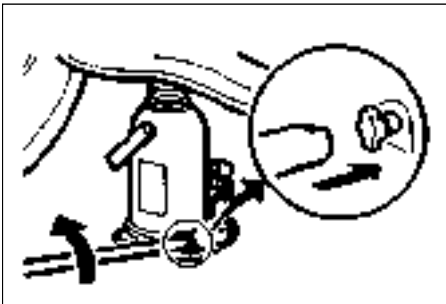

8.INSPECTION AND MAINTENANCE

8.9 Lights and fuses

When changing a light bulb, turn OFF the ignition switch and other light switches. Use a bulb of the specified capacity only.

List of lamps

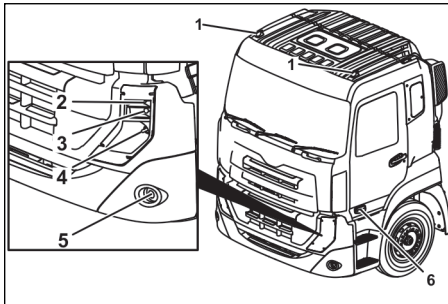

SI No.	Description
1	Front end outline marker lamp
2	Main beam/dipped beam
3	Direction Indicator
4	Parking light
5	Fog lamp
6	Side direction indicator

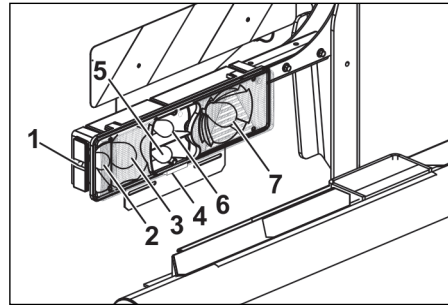

SI No.	Description
1	Side marker light
2	End outline marker
3	Rear fog light
4	Registration light
5	Reversing light
6	Rear indicator light
7	Rear position and stop light

Head light replacement procedure

1. Apply parking brake.
2. Turn OFF the ignition switch.
3. Turn OFF the main switch.
4. Tilt the cab. **Refer “Cab tilting” in Chapter 8**

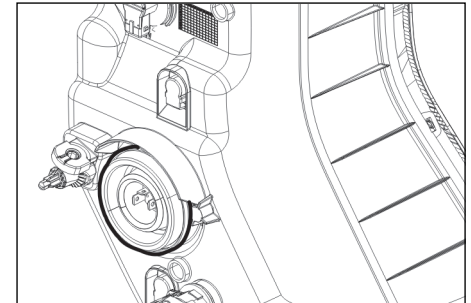

5. Disconnect the connector and pull out the rubber boot.

8.INSPECTION AND MAINTENANCE

6. Press the clip out and release the bulb.

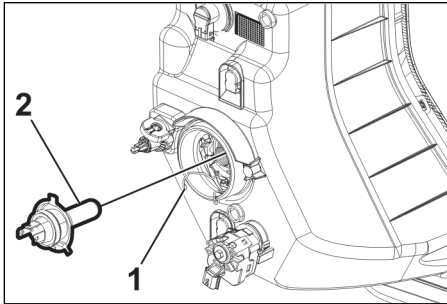

1. Clip
2. Bulb

7. Remove the bulb.
8. Install the bulb.
9. Secure the bulb by pressing the clip.
10. Install the rubber boot.
11. Connect the connector.
12. Lower the cab.

Indicator lamp replacement

1. Apply parking brake.
2. Turn OFF the ignition switch.
3. Turn OFF the main switch.
4. Disconnect the electrical connector.

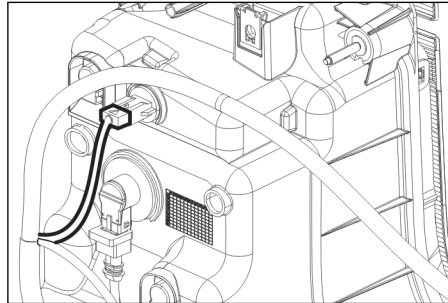

5. Unlock the bulb by rotating it clockwise.

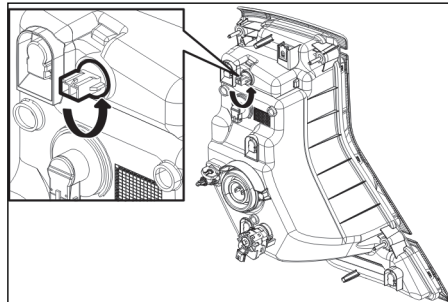

6. Remove the bulb and replace with new bulb.

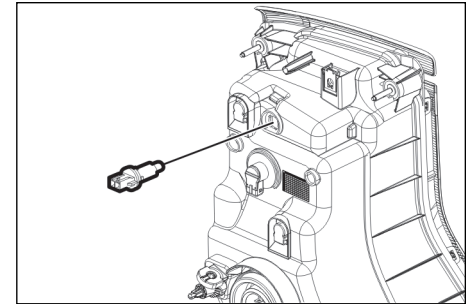

7. Secure the bulb by rotating it clockwise.
8. Connect the electrical connector.

8.INSPECTION AND MAINTENANCE

Parking lamp replacement

1. Apply parking brake.
2. Turn OFF the ignition switch.
3. Turn OFF the main switch.
4. Disconnect the electrical connector.

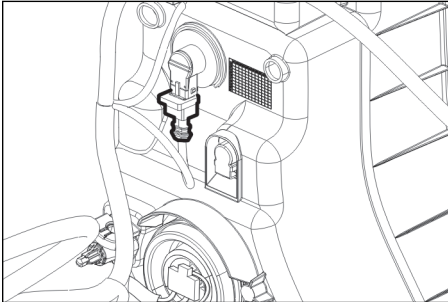

5. Unlock the bulb by rotating it clockwise.

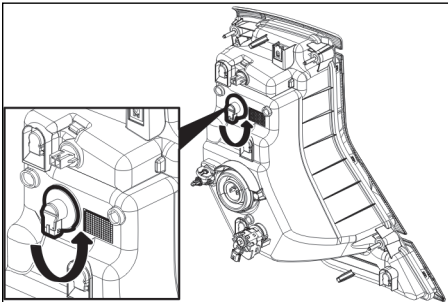

6. Remove the bulb and replace with a new bulb.

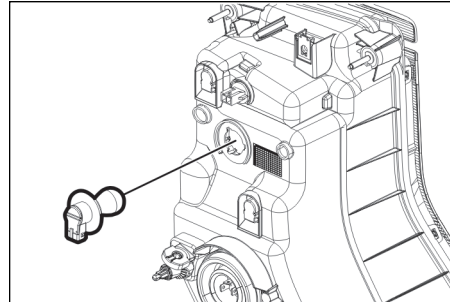

7. Secure the bulb by rotating it clockwise.
8. Connect the electrical connector.

Side indicator lamp replacement

1. Apply parking brake.
2. Turn OFF the ignition switch.
3. Turn OFF the main switch.
4. Remove the cover (2) by removing screw (1).

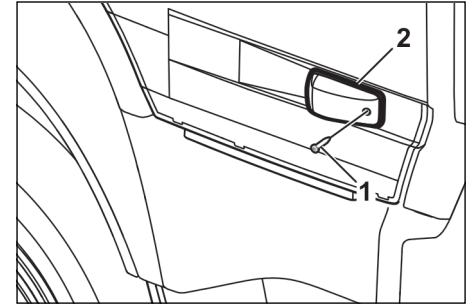

5. Unlock the bulb and remove.
6. Replace with a new bulb and lock it.

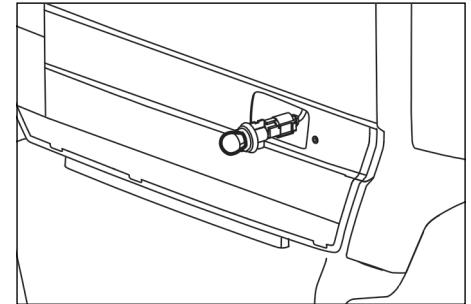

7. Install the cover.

Front end outline marker lamp replacement

1. Apply parking brake.
2. Turn OFF the ignition switch.
3. Turn OFF the main switch.
4. Remove the holder by rotating it clockwise.

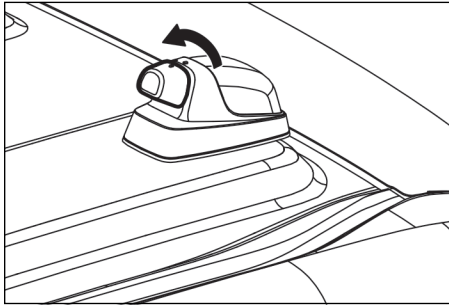

5. Unlock the bulb and remove.

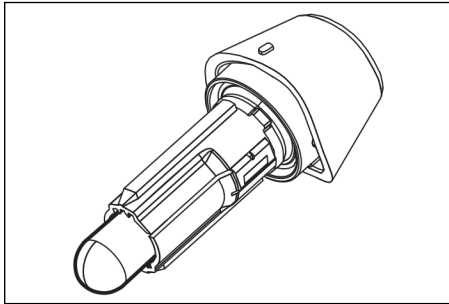

6. Replace with a new bulb and lock it.
7. Install the holder back in place.

Marker lamp side replacement

1. Apply parking brake.
2. Turn OFF the ignition switch.
3. Turn OFF the main switch.
4. Pull the clip and remove the connector.

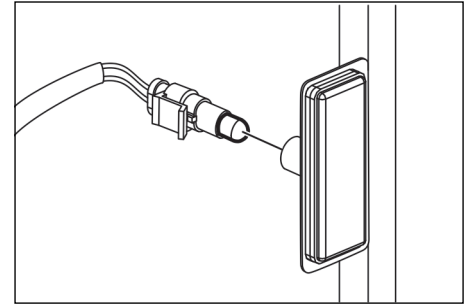
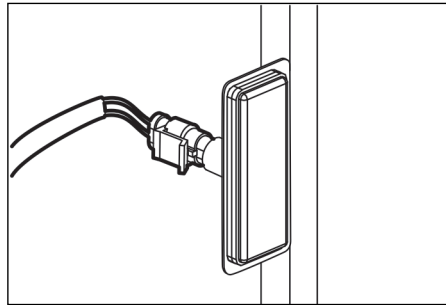

5. Unlock the bulb and remove.
6. Replace with a new bulb and lock it.
7. Connect the connector back in place.

8.INSPECTION AND MAINTENANCE

Cab living room lamp replacement

1. Apply parking brake.
2. Turn OFF the ignition switch.
3. Turn OFF the main switch.
4. Remove cover by pulling it at the one end.

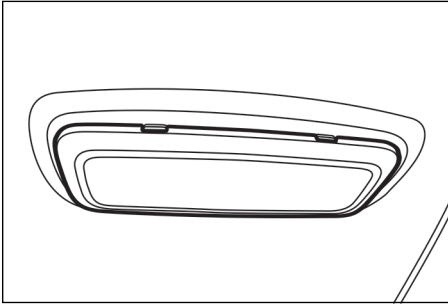

5. Remove the bulb.

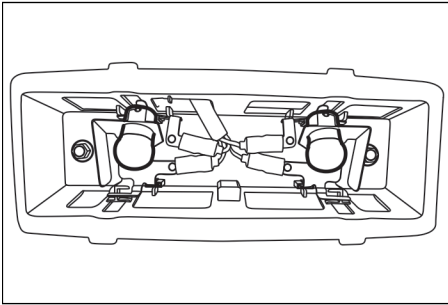

6. Install the bulb.
7. Install the cover back in place.

Cab reading lamp replacement

1. Apply parking brake.
2. Turn OFF the ignition switch.
3. Turn OFF the main switch.
4. Remove cover by pressing it at the one end.

NOTE

Bulbs are in three locations.

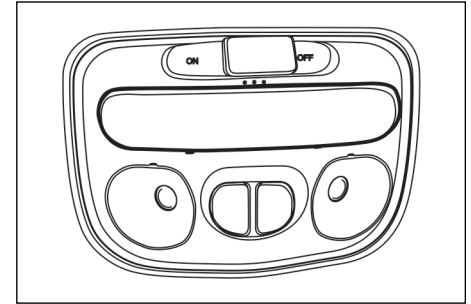
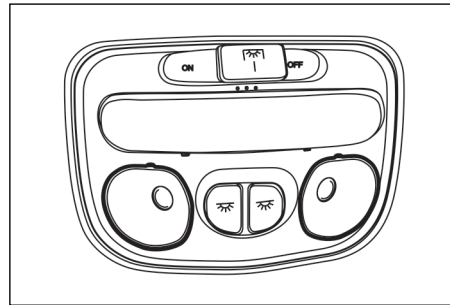

5. Remove the bulb from there location.

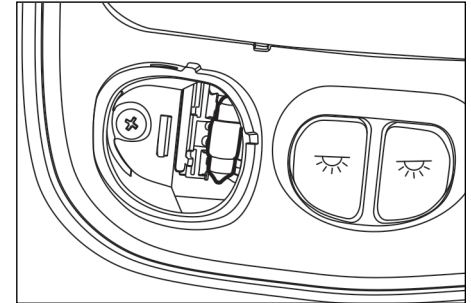

8.INSPECTION AND MAINTENANCE

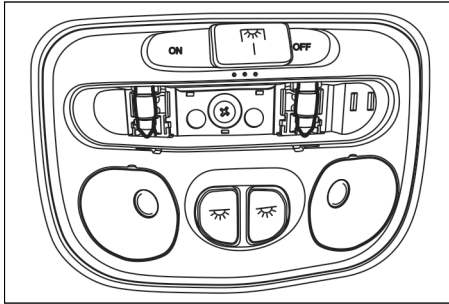

6. Install the bulb.
7. Install the covers back in place.

Cab rear lamp replacement

1. Apply parking brake.
2. Turn OFF the ignition switch.
3. Turn OFF the main switch.
4. Disconnect the connector.

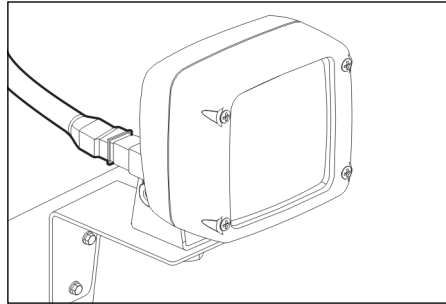

5. Remove the glass and dome by removing screws.

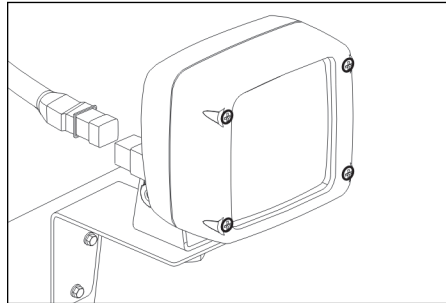

6. Remove the bulb.
7. Install the glass and dome back and secure with the screws.
8. Connect the electrical connector.

Tail lamp replacement

1. Apply parking brake.
2. Turn OFF the ignition switch.
3. Turn OFF the main switch.
4. Disconnect the connector.

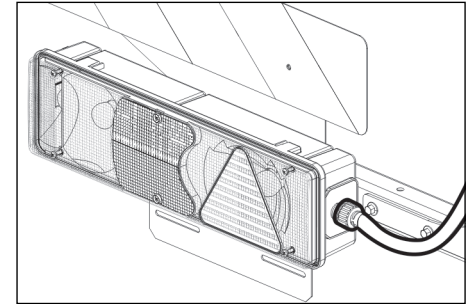

5. Remove the cover by removing the screws.

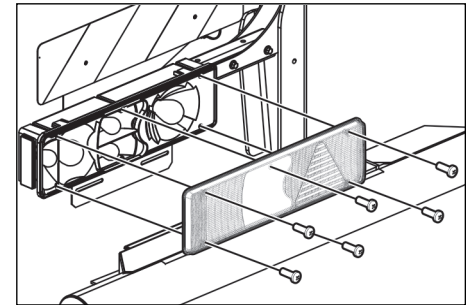

8.INSPECTION AND MAINTENANCE

6. Remove the bulbs.

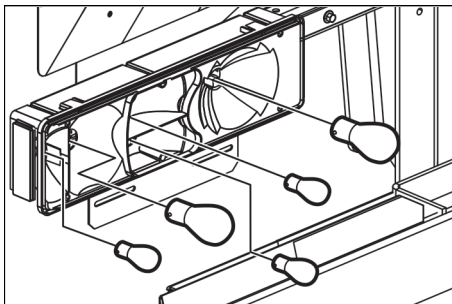

7. Install the bulb.

8. Install the cover back in place.

9. Connect the electrical connector.

Fog lamp replacement

1. Apply parking brake.
2. Turn OFF the ignition switch.
3. Turn OFF the main switch.
4. Remove electrical connector.

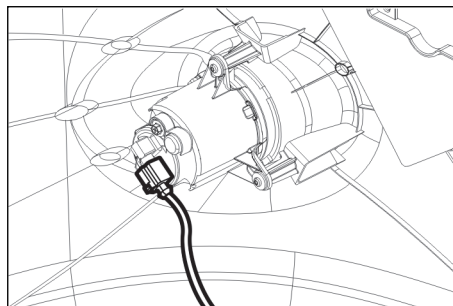

5. Unscrew and open the cover

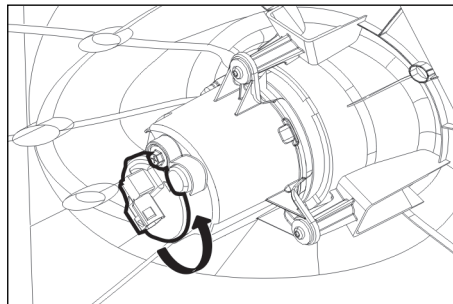

6. Disconnect the electrical wire

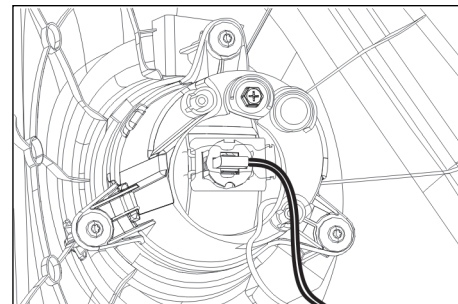

7. Unlock the clip

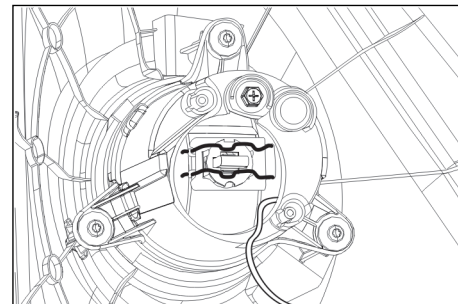

8. Replace the bulb

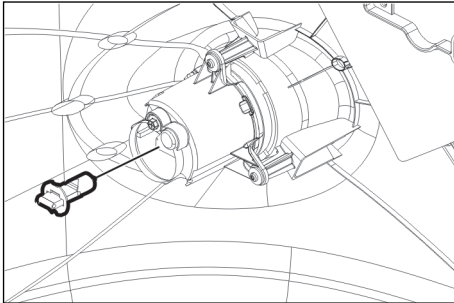

9. Secure the bulb with clip.

10. Connect electrical wire.

11. Install the cover and lock it.

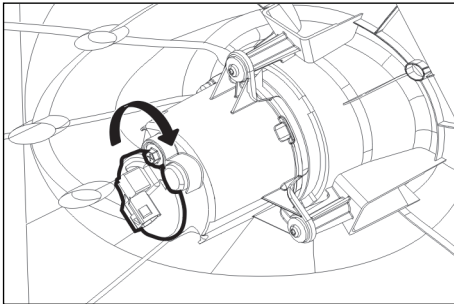

12. Connect the electrical connector.

Blown fuse

The fuse box is located on the lower portion of main dash and consists of mini-type fuses. Also, they are stored in the fusible link box that is located in front of the muffler installed on the right side of the chassis.

Replacement of fuses

Set the ignition switch to the OFF position.

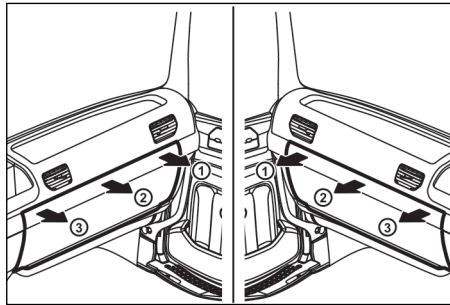

Pull out the assistant lower panel from the top as per the sequence 1 2, and 3. Labels above each fuse specify the circuit current capacity of the fuse to be used in the circuit.

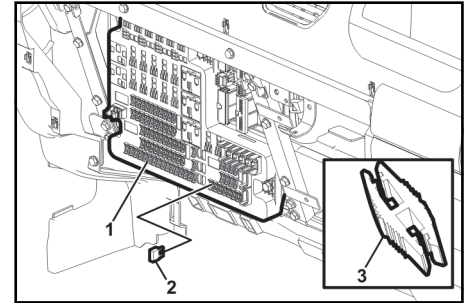

Remove the applicable fuse by checking the indication on the cover and check if the fuse is blown.

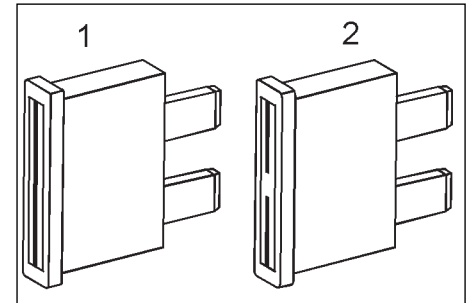

1. Fuse OK

2. Burned Fuse

Some fuses may not be used depending on the vehicle specification.

8.INSPECTION AND MAINTENANCE

- Use the fuse puller to remove the blown fuse.

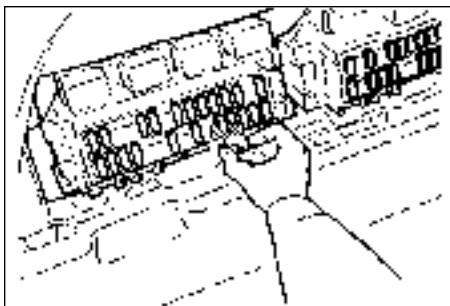

- Install a new fuse with the same current rating as that specified for the circuit.

DANGER

Be sure to use a fuse with the specified capacity. A fuse beyond the specified capacity can overheat or create fire.

NOTE

If the replaced fuse immediately fails again, the electrical system needs to be checked at the nearest UD Trucks authorised dealer.

8.10 Mirror

Image on mirror

- Make sure the side and rear of the vehicle can be seen in the main mirror. The right, left side and rear of the vehicle should be visible in the wide angle mirror. The immediate front side of the vehicle should be visible in the front under mirror. The immediate left side (the side around the front left wheel) should be visible in the close proximity mirror.
- Check that the images in the mirrors are good and mirrors are clean.

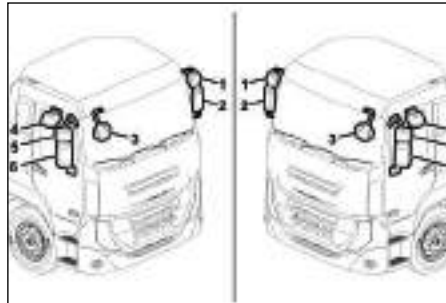

1. Wide angle mirror driver side
2. Main mirror driver side
3. Front under mirror
4. Close proximity mirror-passenger side
5. Wide angle mirror passenger side
6. Main mirror passenger side

Make sure that the mirror arm is secured in a proper position before adjusting the mirror.

Mirror arm drive position

The left/right mirror arms have alignment marks for checking the driving position. Check them visually before driving.

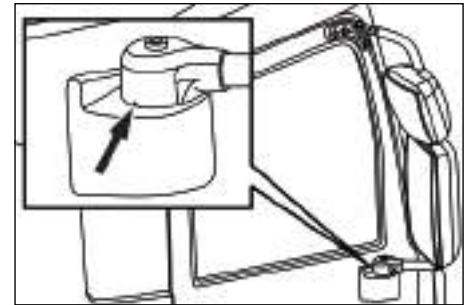

8.INSPECTION AND MAINTENANCE

8.11 Coolant

CAUTION

Using non UD coolant can result in severe consequential damages that will not be covered by warranty.

We strongly recommend to always use **UD** coolant. This prevents the engine coolant from freezing as it has a low boiling point. It also prevents corrosion and formation of scale in the cooling system. For replacement or cleaning, ask the nearest **UD Trucks** authorised dealer.

Water leakage from the cooling units

Check the cooling units such as radiator, expansion tank and radiator hoses for leakage. Check the ground beneath the parked vehicle for signs of leakage. Leakage can be initiated by the pressure applied to the

cooling system (due to operation of the water pump or the increase of coolant temperature). Therefore, check for leakage daily, while the engine is running.

CAUTION

Continuous use of a vehicle with insufficient coolant will damage the engine. If the coolant needs topping up frequently, get it checked at the nearest UD Trucks authorised dealer.

Coolant replacement

Contact nearest **UD Trucks** authorised dealer for coolant replacement.

WARNING

- **Careless opening of the expansion tank pressure cap can cause steam or hot water to spray out, with the risk of personal injury. Follow the handling instructions below.**
- **If the coolant temperature gauge indicator is close to the red zone, keep the engine idling and do not touch the cap until the indicator falls to the suitable level.**
- **Make sure the engine is completely cool. It is dangerous to open the cap while the coolant is hot. The pressurized coolant may push steam/hot water out. When the coolant temperature is low, hold the cap with a rag and open it gently.**

Coolant replenishment

1. Stop the engine.
2. After the engine has completely cooled down, check the engine coolant level in the expansion tank. If the level is between the **MIN** and **MAX** lines, it is normal. If it is below the **MIN** level, add coolant solution up to the **MAX** level.

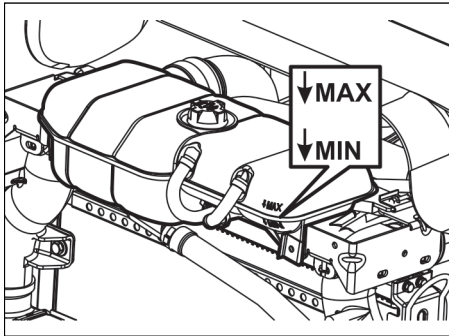

3. Check and make sure that there is no leaks. If found leaks contact nearest **UD Trucks** authorised dealer.

Checking and cleaning of radiator

To maintain cooling system efficiency and keep the engine from overheating, always keep the front radiator core clean. Remove insects, dirt and other debris by directing pressurized air at the rear surface of the radiator core.

CAUTION

Do not direct pressurized air to the front surface of the radiator (that is, with the air hose pointed toward the engine). Doing so will force insects, dirt and other debris into the radiator core and possibly cause engine overheating.

Clean charge air cooler body

The charge air cooler is installed in front of the radiator which is used to cool the heated intake air charged by the turbocharger.

When mud or debris is attached to the front of the core, the passage of cooling air is impaired. So it is recommended that this material should be removed completely by washing with a non corrosive detergent and water solution. (Refer to instructions on the detergent container). Deformed fins can also impair cooling and should be repaired. Clean the inside by blowing with air when changing charge air cooler hoses.

CAUTION

Ensure precautions when washing near the alternator. Using a moist alternator brush will shorten the life of the alternator. Use an alternator that has been sufficiently dried using air-blower.

8.INSPECTION AND MAINTENANCE

NOTE

- Do not use water to clean the inside of the charge air cooler body. Using water will impair cooling due to corrosion.
- When driving on a road near the sea or on the road where deicing agent is applied, wash it completely.

Cooling fan and fan shroud

Check the cooling fan and fan shroud for proper installation, cracks or damage. Replace or repair faulty and damaged parts.

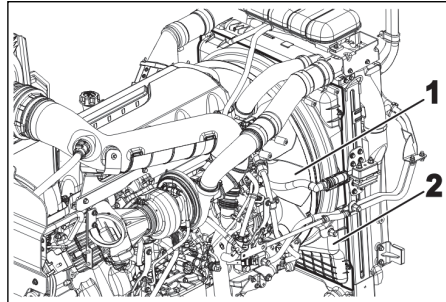

1. Cooling fan
2. Fan shroud

⚠ DANGER

To prevent hand injury, never insert the hand near the fan when the engine is running.

⚠ DANGER

Do not modify the crankshaft or fan pulleys to increase the rated speed of the engine or fan. Doing so, will cause the cooling fan blades to break resulting in injury. Such modification also tampers the noise control system.

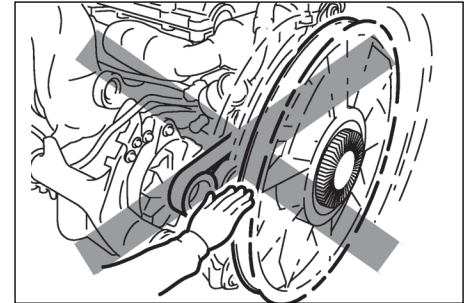

8.12 Brake

Brake pedal free play and braking performance

- Inspection interval: Daily
- Press the pedal gently to check the play. The play is the distance, the pedal travels before resistance is felt. The play in the pedal does not usually change. Any reduction in play will cause the brakes to drag.
- Drive the vehicle slowly and check the braking performance for effect and pulling to one side. Insufficient braking or pulling to one side is dangerous. In this case, contact the nearest **UD Trucks** authorised dealer.

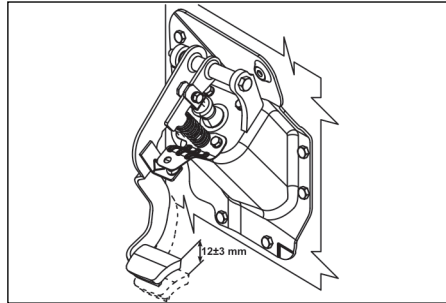

Brake pedal free play: 12 ± 3 mm

WARNING

- There must be no mat or foreign material between the brake pedal and the floor. Failure to comply will cause the pedal not to return completely, resulting in brake drag causing accidents.
- Always ensure that the area around the pedals is free from rubbish, objects etc. which could impair the braking operation.

NOTE

Be aware of the ambient traffic conditions when driving to test the brakes.

8.INSPECTION AND MAINTENANCE

Clearance check between brake drum and lining, and check for wear

Inspection

Inspection time: Every month

Stop the vehicle. Turn OFF the engine. Chock the wheels to prevent the vehicle from moving and then switch the parking brake lever to the driving position and release the spring brake.

Remove the rubber plug and insert a thickness gauge through the inspection hole. Check the clearance between the lining and the brake drum. There are two inspection hole available per wheel. Use each hole for checking the clearance.



1. Thickness gauge
2. Drum
3. Lining

Standard clearance value

0.4 to 0.6 mm at shoe center

*Since the automatic adjusting mechanism is provided, adjustment during operation is not required.

Check the brakes of each wheel in the same way.

Wear check

Remove the rubber plug from the inspection hole and check for wear of the brake lining. If the brake lining is worn to the stepped portion, replace it with a new one. In addition, check for damage such as cracks or abrasion on the edge of the brake lining through the inspection hole. If damage is found, contact the nearest **UD Trucks** authorised dealer and have the vehicle inspected.

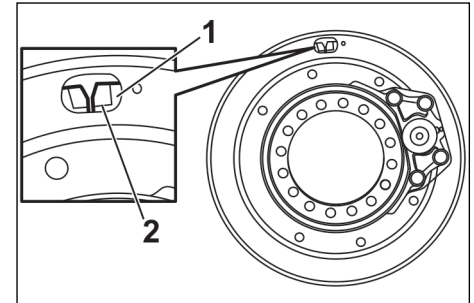

1. Lining
2. Maximum wear position (Replace the brake lining, when the wear out reaches this position).

Check for noise from brakes when pressing the brake pedal gently while driving the vehicle at a slow speed. If noise is heard, the rivet that secures the brake lining may have become loose. Contact the nearest **UD Trucks** authorised dealer and have the vehicle inspected.

CAUTION

Do not drive the vehicle when the operation limit is exceeded. Operation over the limit may damage the drum with the rivet head. This may greatly lower the braking performance.

NOTE

Be aware of the ambient traffic conditions during the test drive for the brake.

Performance of parking brake

Inspection time: Every month

Stop the vehicle on a dry slope (downhill) and apply parking brake and check if the vehicle can stay there. If the vehicle fails to stay, contact **UD Trucks** authorised dealer

Air actuated type

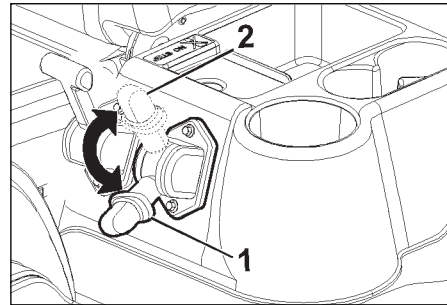

1. Drive position
2. Park position

Parking brake operation (air brake)

Apply the parking brake and ensure smooth and complete operation of the spring brake actuator push rod.

Axle shaft bolt checking

Inspection time: Every 3 months

Tighten the axle shaft bolt to the specified torque using a torque wrench.

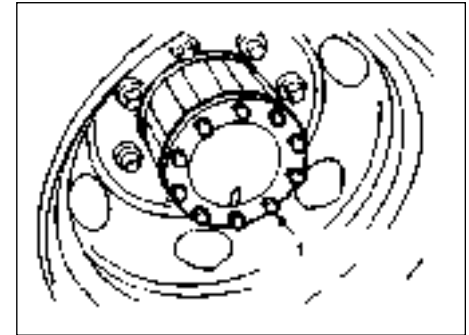

Tightening torque 157 +/- 9 Nm

8.INSPECTION AND MAINTENANCE

Clutch pedal check

Inspection time: Every 3 months

- When the clutch disc wear increases based on the operation of the vehicle, the clutch pedal play gradually increase and the clutch engagement position changes leading to excess play of clutch pedal. If the play exceeds 4-6mm check and service at the nearest **UD Trucks** authorised dealer.

NOTE

- **Perform the check by paying attention to the ambient traffic conditions.**
- **During this check, make sure that the vehicle does not start accidentally**

Condition of reflector and license plate

- Check for dirt or damage on the reflector and license plate.
- Check if the license plate is correctly installed and the letters are clearly visible.

Treatment for emission and external noise

Automobile emission and noise are specified in the safety standard (noise and emission regulation). The regulation values must be satisfied. This section describes the simple check and service for emission control and noise control units that may be performed by customers. With regular inspections and correct operations, can minimise the adverse impact on the environment.

Treatment of parts for emission Emission status

- Emission colour represent the good or bad status of combustion. Check the emission carefully on a daily basis.
- **No color or light blue:** Normal
- **Black:** Incomplete combustion of fuel
- **White:** Combustion of engine oil. If the temperature is low and the engine is not warmed up, the emission may be white.

Air cleaner

If the air cleaner filter is clogged, results in black smoke from the exhaust. Check and replace the filter on a regular basis.

Exhaust system inspection

WARNING

Avoid checking the silencer after driving, when it is hot. The hot exhaust pipe and silencer will cause injuries, check only when the silencer is cold.

Inspection period

Inspection interval: Every year.

Inspection procedures

Check for any damage to the silencer main unit, the nozzle (dosing module), the sensor and the wirings and hoses that are connected to those components

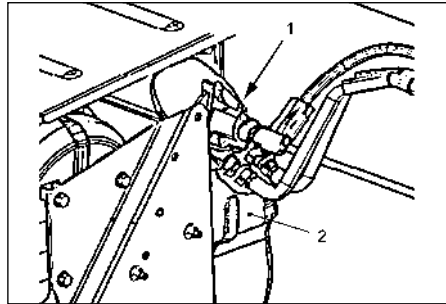

1. Dosing module
2. Muffler

Other

Failure of parts related to emission not only exceeds the regulation value of the safety standard, but also causes an increase of fuel consumption, increase of oil consumption and reduction of power.

If a failure is found, ask for service at the nearest **UD Trucks** authorised dealer

Treatment of parts related to external noise

Noise proof system if equipped

- A cover and noise absorbing material shown in the figure is installed to reduce external noise and meet the regulation value specified in the "Noise regulation". If it is removed for maintenance, be sure to reinstall it at the original position.
- Cover and noise absorbing materials are used to maintain the noise level. Do not modify or drive without it. Check it on a regular

8.INSPECTION AND MAINTENANCE

basis to prevent the function from being degraded due to damage, deformation or corrosion

NOTE

When maintaining the vehicle or washing with a high pressure device, ensure care to avoid damage to the noise absorbing material.

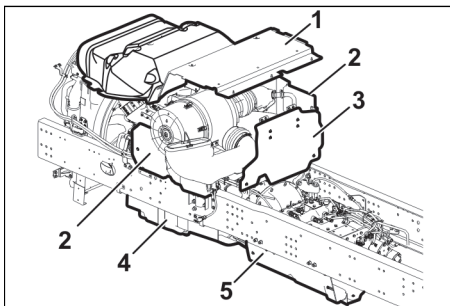

1. Noise shield under the cab
2. Noise shield engine side
3. Noise shield behind cab
4. Noise shield under engine
5. Noise shield under transmission

Silencer and exhaust pipe

- Damage or corrosion to the silencer and exhaust pipe may degrade the silencing function. Check it on a regular basis. If a failure is found, replace the part.

NOTE

When driving in an area which has a high salt content, such as driving near the sea or on the road where deicing agent is applied, rust may occur on the surface of the silencer. Continuing to drive the vehicle with rust will damage the silencer. After driving in the area which has a high salt content, always wash the surface of the silencer with water.

Air dryer

⚠ CAUTION

Failing to replace the air dryer on the recommended intervals will result in consequential damages to the pneumatic systems and components.

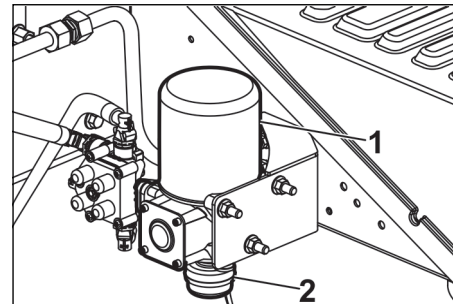

1. Air dryer
2. Release valve

Check visually if air is discharged from the air dryer outlet. (The amount of exhausted air will be more at beginning).

8.13 Tools

General tools required for the daily check and service are placed in the vehicle.

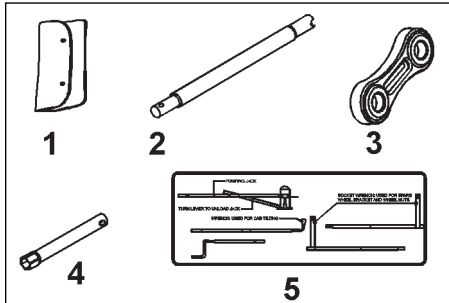

1. Tool bag
2. Extension bar
3. Towing brace
4. Socket wrench
5. Decal hand tool applications

8.INSPECTION AND MAINTENANCE

8.14 Oils

Engine oil recommendations



CAUTION

We strongly recommend to always use UD lubricants. Using other oils and lubricants will result in severe consequential damages and cancellation of warranty.

It is important to check and replace lubricants on a regular basis for longer life, safe and comfortable driving of the vehicle.

This section summarizes the checks and service that can be performed by users regarding lubrication. Lubricants that are in use and their corresponding regular replacement intervals are indicated on the list in the “Service data” and “Maintenance schedule” chapters.

UD lubricants are prepared for the full performance of the vehicle. Always use **UD** lubricants for regular replenishment and replacement.

NOTE

Check or replace items that indicate both the service interval and the driving distance, which ever is earlier.

Precautions for replenishment and replacement of oil

Incorrect service work may cause leakage of oil. Ask for service at the nearest **UD Trucks** authorised dealer.

During inspection and service, observe the following items:

- Be sure to prepare the drain oil container.

- Perform the work in a location where an oil disposal unit is available.
- Always dispose of waste oil according to environmental directives.

Checking and replacement of engine oil



WARNING

To avoid serious injury from a hot engine or oil, check the oil level and perform maintenance only after the engine has cooled down.

Check the engine oil level before driving the vehicle on daily basis when the engine is cool. When checking after switching OFF the engine, wait for the engine to cool down and allow the oil to return to oil pan.

To check the engine oil level

1. Park the vehicle on a level surface.
2. Remove the dipstick located on the left hand side of the engine. Wipe it clean with a clean cloth and reinsert it. Remove the dipstick and check the oil level. Maintain the engine oil level between the MAX and MIN mark on the dipstick.

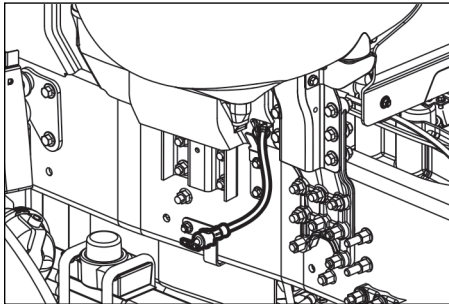

3. If the oil level is low, add oil through the oil filler port (1) located on top of the engine. Do not add oil above the MAX mark on the dipstick.

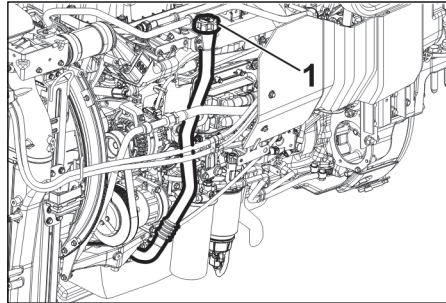

1. Oil filler cap

WARNING

Handle oil with care to avoid spilling. Do not add oil if the engine or exhaust system is hot. Spilling oil on hot parts can result in a fire.

- 4 After adding oil, wait at least for 10 minutes, then recheck the oil level.
- 5 After checking, insert the engine oil dipstick.

CAUTION

- Do not drive the vehicle with the engine oil level below the LOW mark on the engine oil level gauge. Driving with the engine oil level below the LOW mark will lead to engine seizure.
- Use care to keep dirt and debris from entering the crankcase through the oil filler port when adding engine oil.

Replacement of engine oil

Oil capacity

Refer “Capacities” in Chapter 11

8.INSPECTION AND MAINTENANCE

Changing the engine oil

WARNING

To avoid serious injury from hot engine and engine oil, change the oil after the engine has cooled.

WARNING

Avoid direct skin contact with used oil. If skin comes in contact wash thoroughly with soap and plenty of water.

To change the engine oil

1. Park the vehicle on a level ground.
2. Remove the oil filler cap.

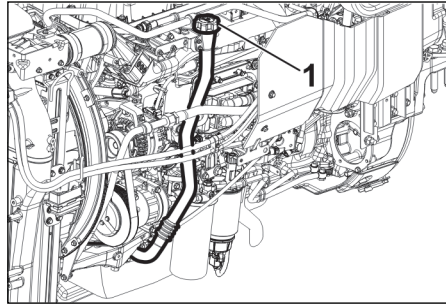

1. Oil filler cap

3. Place a container under the drain plug below oil pan. Remove the plug and drain the oil completely into the container.

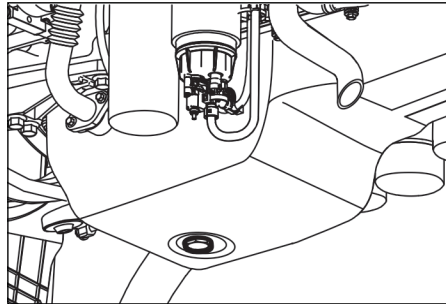

4. When the complete oil has been drained from the oil pan, replace the drain plug in the drain hole and tighten the drain plug. Use a new washer each time the drain plug is removed.
Tightening torque:
54 - 59 Nm (5.5 - 6.0 kgfm)
5. Replace the oil filter.
6. Add **UD** oil through the oil filler port.
7. After refilling the engine oil, wait for at least 10 minutes, then check the oil level using the dipstick. If the engine oil level is low, add oil until the level on the dipstick is between MAX and MIN.
8. Start the engine and check for oil leaks.

8.INSPECTION AND MAINTENANCE

Replacement of transmission oil.



CAUTION

Using non UD lubricants can result in severe consequential damages, which will not be covered by warranty.

For oil capacity Refer “Capacities” in Chapter 11

Initial replacement:

First oil change interval after 4 weeks or maximum 5,000 km

Replacement procedure



DANGER

Avoid burning the skin with hot transmission oil. Replace the transmission oil only when the transmission and engine is cool

1. Place a container under the drain plug. Remove the drain plug and completely drain the transmission oil.

NOTE

The drain plug contains a magnet. Remove any metal filings from the plug before installing it.



2. Reinsert the drain plug and tighten.

3. Refill the oil through the filler plug hole, until oil overflows the level plug hole.

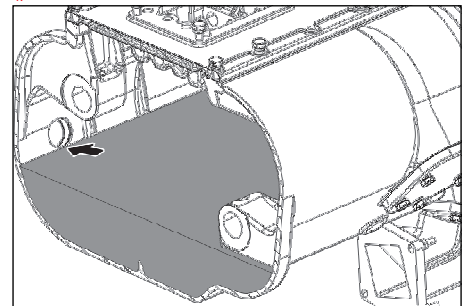
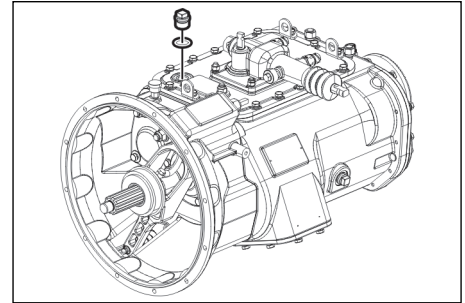

8.INSPECTION AND MAINTENANCE

5. Reinsert the filler plug and tighten.

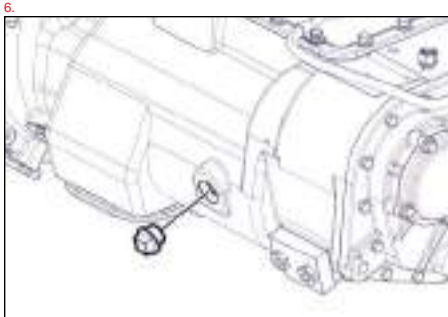

CAUTION

Use a funnel while pouring oil to avoid the filler plug hole dirt from entering into the transmission.

NOTE

For PTO oil change it is not only enough to drain oil from main transmission but also from PTO as shown in below picture.

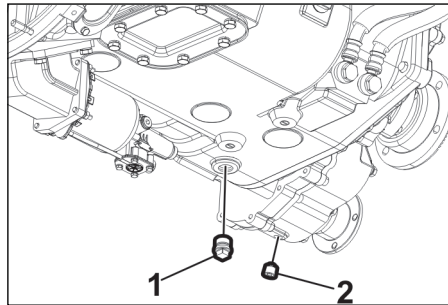

1. Drain plug transmission housing
2. Drain plug PTO housing

CAUTION

Oil is deteriorated with increase in the temperature, which in turn causes failure of the transmission. Oil in vehicles operating under rough conditions tend to heat fast and deteriorate quickly. Replace the oil earlier than usual.

After replacement, make sure that the oil is filled to the specified position (lower surface of the oil level plug). Insufficient or excessive amount of oil will cause failure of transmission.

Replacement of differential gear oil

CAUTION

Using non UD lubricants can result in severe consequential damages, which will not be covered by warranty.

Initial replacement:

After initial 5,000 km or 1 month
(Whichever comes first.)

Replacement procedure

1. To drain, remove the drain plug. Clean the magnet in the drain plug which collects accumulated iron sediments in the oil.

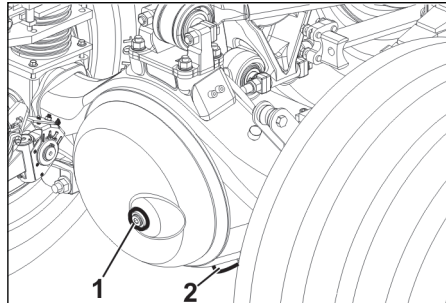

1. Filler plug
2. Drain plug

2. To refill, remove the filler plug and pour **UD** oil into the case through the filler plug hole.

Tightening torque:

Drain and filler plug

80 ± 16 Nm {8.15 - 1.63 kgfm}

3. When refilling, ensure care to avoid dirt or dust from entering the filler plug hole.

WARNING

Check or replace the differential gear oil after the rear axle is cooled to avoid injuries.

CAUTION

Use a funnel while pouring oil to avoid the filler plug hole dirt from entering into the axle.

Before removing the oil filler plug, clean the plug and the area around the plug.

8.INSPECTION AND MAINTENANCE

Replenishment of power steering oil

WARNING

- Allow the steering system to cool down before carrying out an oil check or replacement.
- If there is insufficient oil or it is dirty, the power steering may not operate correctly. Do not drive the vehicle in this condition. Replenish or replace the oil.

CAUTION

It is strongly recommended to use UD lubricants in order to avoid severe consequential damages.

Oil filter cartridge

Replace the oil filter cartridge every time the power steering oil is replaced.

Capacity:

Check the amount of oil using the dipstick provided in the reservoir. Recheck the oil level after running the engine for a short time. Check for power steering oil leakage at the joints in the steering line.

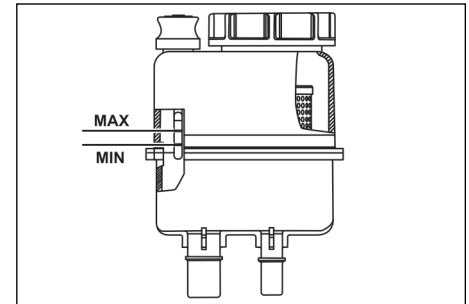
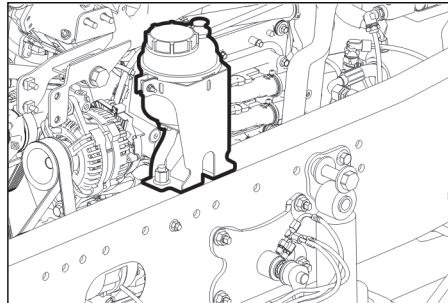

1. MAX
2. MIN

NOTE

- Be sure to check the amount of power steering oil when the engine is not in operation.
- When oil is replaced, replace the filters as well.

Check and replacement of clutch fluid



CAUTION

It is strongly recommended to use UD lubricants in order to avoid severe consequential damages.

Checking clutch fluid level

⚠ DANGER

- Check or replace the clutch fluid after the engine is cooled to avoid burns.
- Make sure that the clutch fluid does not come in contact with a heated exhaust pipe to avoid fire accident.

marks on the reservoir. If it is lower than the LOW mark, add UD clutch fluid till the HIGH mark.

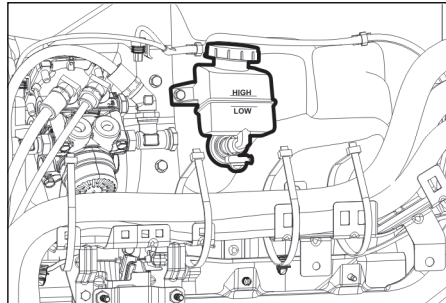

- Open the front panel and check the fluid level in the clutch reservoir.
- The fluid level is correct if it is between the HIGH and LOW

8.INSPECTION AND MAINTENANCE

Precautions for handling clutch fluid

- Since the clutch fluid has a strong characteristic of moisture absorption, it must be carefully handled. While the clutch fluid is checked, replenished or in stored ensure that it is not exposed to moisture.
- Inclusion of other mineral oil (diesel oil, gasoline, etc.) in the clutch fluid may swell the rubber of the clutch system, resulting in a failure.
- Adhesion of the clutch fluid on the coating surface may peel the coat. Ensure proper care during replenishment.



CAUTION

- **If the clutch fluid level is low, it is necessary to check if there is any leakage in the clutch system. Have it inspected at the nearest UD Trucks authorised dealer.**
- **Remove dirt in and around the cap before removing the cap of the clutch fluid reservoir. When the cap is removed, avoid contact with dirt, dust, water or foreign material.**
- **Use clean container for replenishment of the clutch fluid. Never use a dirty container that has paint or mineral oil.**

Lubrication

NOTE

Lubricating service is very important when it comes to service and maintenance of the truck. Vehicle components such as the engine, transmission, rear axles, etc., must be lubricated with either oil or grease. The following information about oils and greases is important. UD Trucks authorised dealer has more information on the complete range of lubricants.

8.15 Coupling

Care

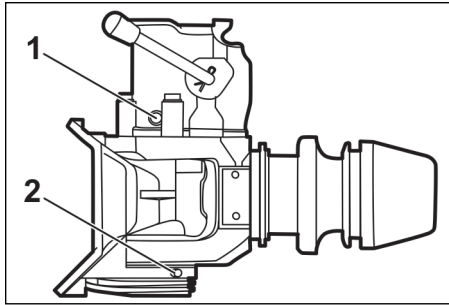

Before starting maintenance work on the hitch ensure that hitch is closed.

- Lubricate coupling bin, support ring and drawbar eye with recommended heavy duty grease. Lubricate before the first use and at recommended intervals.
- Under rough operating conditions or on severe exposure to dirt and water re-grease the automatic unit (1) when coupling is open
 - **Refer respective manufacturers manual for maintenance intervals.**
- Lubricate lower funnel bearing (2) with recommended grease.

NOTE

Close coupling before cleaning with high-pressure washers.

- After cleaning, re lubricate coupling pin and support ring with recommended grease.

Please note the following when carrying out repairs on coupling

(e.g. changing coupling pin):

- Remove the old grease.
- Re lubricate with recommended grease.

Inspection



WARNING

There is risk of accident if the coupling play is not corrected.

Longitudinal play

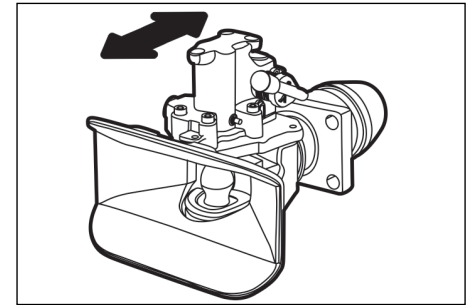

Grip coupling head (not jaw funnel) with both hands when uncoupled and move vigorously in longitudinal direction. Ensure that there is no longitudinal play.

8.INSPECTION AND MAINTENANCE

Vertical play

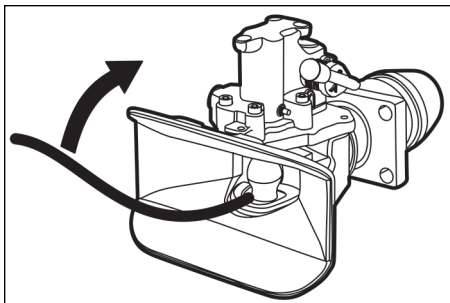

- Open hitch.
- Move coupling head up and down with appropriate tool. Vertical play should not exceed 3 mm measured at coupling head (centre axis of coupling pin).

Coupling pin

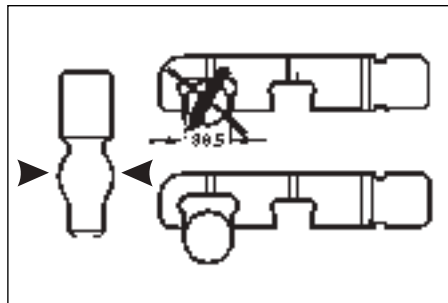

Check wear, coupling pin may be used until diameter of crowned section has worn to less than 36.5 mm, after which it must be replaced.

Vertical play in coupling pin should not exceed 2 mm.

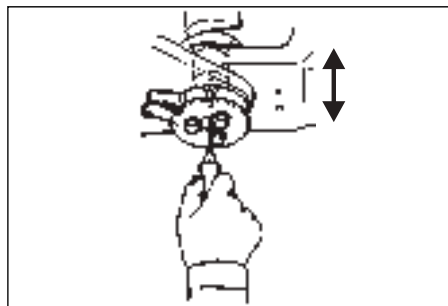

Lower bush

Check wear for internal diameter of the lower bush, maximum admissible internal diameter of lower bush is 31.5 mm. for C-RO400G and 35.9 mm for C-RO50
Passage below pin must be free.

Please visit nearest **UD Trucks** authorised dealer for replacement.

Support ring

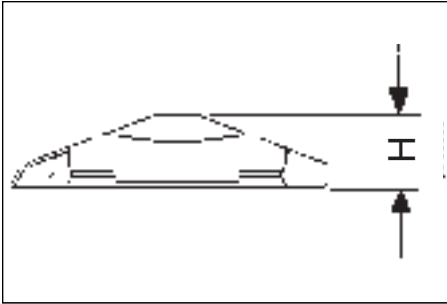

Support ring for drawbar eye must be replaced, if the drawbar eye touches the lower bush because of wear. The wear limit "H" should be a minimum of 14 mm for C-RO400G and 12 mm for C-RO50h as been reached.

Always lubricate the support ring with recommended grease to reduce wear. Consult **UD Trucks** authorised dealer for replacement.

CAUTION

Lower bush must not be damaged under any circumstances as this will impair closure of coupling. Ensure care to avoid accidents.

Check funnel lock

NOTE

The funnel must be locked in its central position, when coupling is opened to for operation.

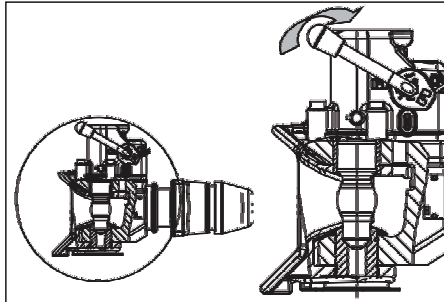

Push the funnel along the side

- Move hand lever in locking direction (up).
- Release funnel.
- The funnel must swing back to central position and should be locked again.
- If not, contact nearest **UD Trucks** authorised dealer for assistance.

Adjustment

CAUTION

Contact nearest UD Trucks authorised dealer for coupling adjustment.

8.INSPECTION AND MAINTENANCE

8.16 Wiper blade

Replacement procedure

- 1 Apply the parking brake.

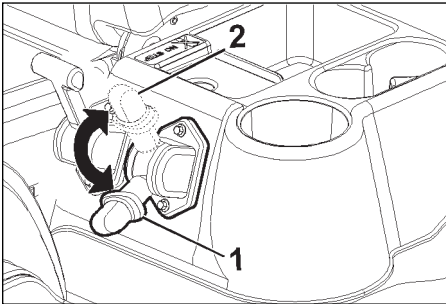

1. Parking brake released
2. Parking brake applied
- 2 Chock the wheels.
- 3 Pull the wiper arm

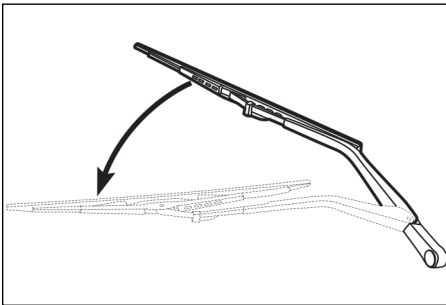

- 4 Press and pull the lock.

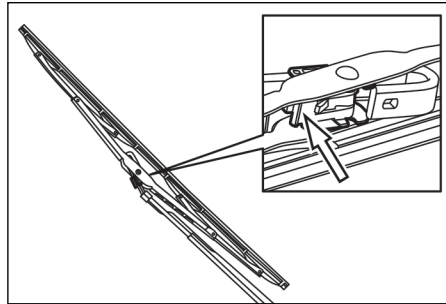

NOTE

Keep the wiper arm in pulled condition throughout the operation, to prevent damage to the wind shield.

- 5 Replace the wiper blade and lock it.

NOTE

Make sure that the blades are locked in position.

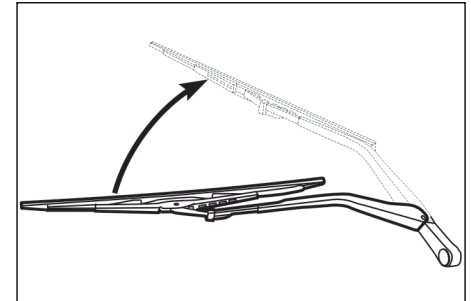

- 6 Place back the wiper arm on wind screen.
- 7 Check for wiper blade function.

8.17 Washing the vehicle

Vehicle washing precautions

- When washing the vehicle, prevent the entry of water into the electrical components. Do not use high pressure steam or water to contact the electrical wirings, wiring connectors and electrical components that are located around the chassis and inside the cab.
- Before washing the vehicle, cover the opening of the engine air inlet in order to prevent water or foreign materials from entering.



CAUTION

Avoid water to come in contact with alternator. Failure to comply will lead to alternator damage.

Precautions while washing around the silencer

When washing around the silencer, perform the following procedures.

High pressure washing

Spray 1.5 meters away from the silencer.

Removing mud or snow

Use only a soft cloth or a washing brush, even if the silencer is extremely stained. Never use a shovel or a handle of a washing brush for this purpose. Doing so will damage the sensor, harness and connector.

NOTE

When driving in regions with high salt content or on road where deicing agent is applied, the silencer surface starts to corrode. Clean the silencer frequently to prevent the corrosion.

8.INSPECTION AND MAINTENANCE

Precautions while washing the undercarriage

When washing the undercarriage, do not apply the steam or water directly from a pressure washer on the steering shaft joint, sector shaft joint, and rubber boots of drag link and tie rod. Doing so could cause malfunction.

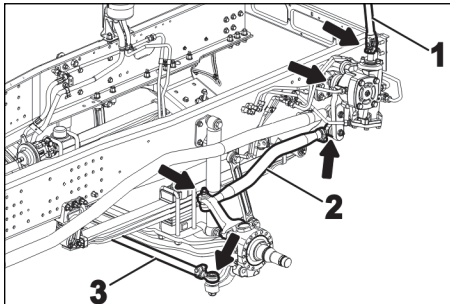

1. Steering rod
2. Link rod
3. Tie rod

Precautions cleaning vehicle lights

Follow the instructions below when clean the vehicle lights

When performing a high pressure wash

Follow the instructions below when clean the vehicle lights

- Spray from a distance of at least 1.5 m from the lights. Further, when focusing washing on one area, do not continue to spray the same place for more than 5 seconds. Spraying from a closer range could allow water to get into the lights
- Use water pressure under 5 MPa {50 kgf/cm²}, when using a high-pressure wash.
- When using body shampoo, rinse well with water to remove all body shampoo from the lens body. Failure will lead to cracks on the lens surface.

8.18 Handling of exhaust (applicable for Euro IV/China IV or equivalent standard)

NOTE

Not applicable for Euro III/China III or equivalent models.

Exhaust emission control system

The after-treatment system that cleans the exhaust gas uses urea water solution (AdBlue®) in the Silencer to decompose the NOx in the exhaust gas into water and nitrogen to reduce NOx emission.

Dosing system for emission control

If a fault occurs in the NOx dosing system then a message is shown on the display together with the yellow warning lamp (CHECK). The urea dosing system (supply module, dosing module) continues to operate for approximately 120 seconds after

the ignition is turned OFF. Therefore, wait for at least 120 seconds before disconnecting the battery cable or electrical system connectors when servicing the vehicle.

Handling of the silencer

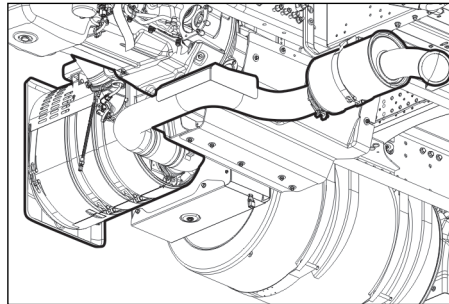

The silencer is specially integrated with a catalyst which does not require inspection and servicing. It should be replaced if there is any external damage. Replace it with **UD** Genuine Parts.

Do not kick or strike the silencer.

CAUTION

Do not climb, stand or strike the silencer. Failure to comply will damage the catalyst inside

The silencer has the following characteristics.

- The after-treatment system cleans and discharges the exhaust gas, so the exhaust gas smells differently than that of conventional diesel vehicles.
- White vapour comes out from the exhaust pipe when the engine is started. Do not mistake this for a malfunction.

8.INSPECTION AND MAINTENANCE

Do not modify the tail pipe.

CAUTION

Do not modify the tail pipe it will degrade the exhaust gas cleaning effect.

Precautions to be taken when filling AdBlue

CAUTION

AdBlue is not dangerous but should be handled with caution. If AdBlue is accidentally spilled on the truck, rinse with water and then wipe with paper or cloth. The solution can be aggressive when it gets hot and can damage the adjacent connectors, cables and hoses in the event of leaks.

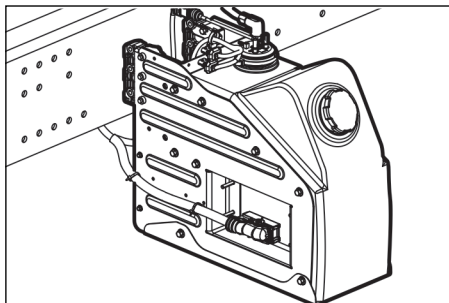

- The filler cap is locked by means of a key lock.
- Tighten the cap on the filler after supplying the solution.

Handling AdBlue

WARNING

AdBlue is nonflammable, but it should be moved to a safe location if there is a fire, as intense heat may cause the sealed storage container to pressurize and possibly rupture.

Use only urea water solution (AdBlue) specified by **UD Trucks** that satisfies the ISO22241-1.

- The specified urea water solution (AdBlue) is colorless (urea 32.5%, water 67.5%) and begins to freeze at -11°C . When the outside air temperature is low and the vehicle has been exposed to cold temperatures for a long time, the indicator in the cab might not show the correct solution level
- Use the special container recommended by the urea water solution (AdBlue) dealer to hold the urea water solution (AdBlue). General containers, containers that have been used for other applications, and dirty containers will not maintain the quality of the urea water solution (AdBlue). So make sure not to use them.

CAUTION

Do not drive the vehicle when the AdBlue tank is empty. Ensure the AdBlue tank is full always.

WARNING

Handle Adblue with proper care, avoid contact with skin. If it is spilled on the body, wash with water immediately.

Handling filler cap

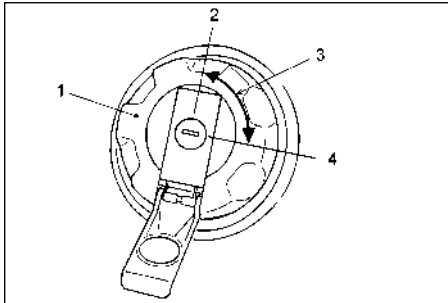

1. Cap
2. Unlock position
3. Turning angle
4. Lock position

Removing the filler cap

- When the cap is locked, the cap rotates freely and cannot be opened. Insert the AdBlue tank key and unlock it by turning the cap 90° to the left. Remove the key after unlocking.

When the cap is not locked, the cap does not rotate freely, the cap can be opened.

- Turn the cap to the left to remove it and then fill the tank with urea water solution (AdBlue)

Attaching the cap

- Turn the cap to the right until it locks.
- Insert the AdBlue tank key and turn it 90° to the right to lock the cap. Remove the key while it is in this position.

NOTE

- Turn the key until the cap is locked. The key will lock the cap only when it is in the lock position.
- To remove the key, turn it all the way to the lock or unlock position. Trying to remove the key in between these positions will damage it the key and lock.

When fire or leak occurs

- Urea water solution (AdBlue) is non-flammable, but quickly move it to a safe location if there is a fire.
- If urea water solution (AdBlue) is spilled, wash it away with water. It can be disposed off by diluting it with a large amount of water and then pouring it into the sewage system. It must be treated as industrial waste in areas with nitrogen restrictions.

8.INSPECTION AND MAINTENANCE

8.19 Fifth wheel

Inspection and lubrication

WARNING

All maintenance must be performed by a UD Trucks authorised dealer only. All maintenance must be performed while the tractor is uncoupled from the trailer. Failure to follow all the maintenance procedures contained in these instructions will result in accidents.

Maintain the adequate lubrication on the following by inspecting and re lubrication at recommended intervals. Contact your **UD Trucks** authorised dealer for maintenance intervals.

20 tonne

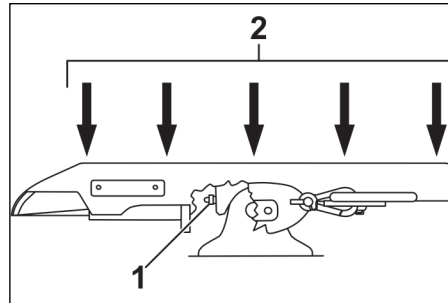

1. Bracket supports
2. Trailer contact surface

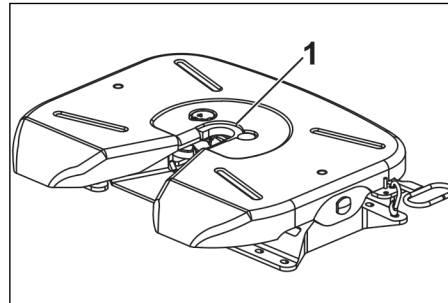

1. Lock jaws and front lock wear ring (king pin contact area)

28 tonne

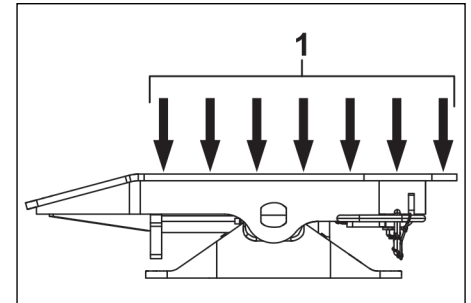

1. Trailer contact surface

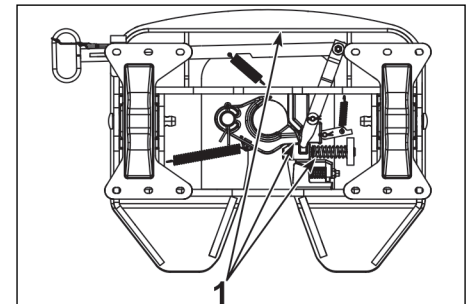

1. Lock, plunger, wedge and front lock

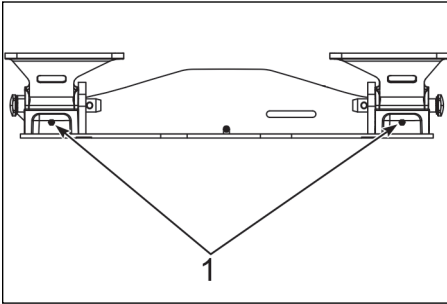

1. Bracket contact surface

Inspection and lubrication

- Tighten the loose bolts and fasteners
- Replace the missing or damaged parts.

CAUTION

To adjust the fifth wheel contact nearest UD Trucks authorised dealer.

8.INSPECTION AND MAINTENANCE

8.20 Vehicle storage

CAUTION

Store the vehicle only in an closed and ventilated garage free from rodents, floods, snowfall. Warranty does not cover vehicle affected due to rodents, flood, earthquakes, etc.

If the vehicle has to be stored for a short or long period, it has to be prepared for storage. It is always advised to store the vehicle in an enclosed and well ventilated shed free from rodents, flood, sand, snowfall.

Preparing for storage

- Perform a road test to identify the issues in the vehicle and rectify the same.
- Clean the vehicle completely.
- Check the oil and other fluid levels in the vehicle.

- Inflate the tyres based on the pressure provided by the tyre manufacturer.
- Release parking brake and chock the wheels.
- Disconnect the battery and apply petroleum jelly on the battery terminals.

WARNING

To disconnect the battery, remove the negative terminal first and remove the positive terminal. While connecting connect the positive terminal before connecting the negative terminal.

- Move the windscreen wipers away from the windscreen
- Apply lubrication and grease on all the required points.
- Close all the openings in the vehicle such as exhaust, air inlet, etc to avoid entry of air and dust.

- Clean and remove the rust in the body, if required paint the spot again.

Maintenance of vehicle during storage

- Check the oil, fluid levels.
- Check the battery charge.
- Check the tyre pressure and inflate if required
- Clean the vehicle.
- Ensure all the openings are closed.
- If possible connect the battery and start the engine periodically.
- Check the fan belts etc.

8.21 Greasing

Greasing should be performed periodically. Wipe all dust and dirt from the grease nipples with a cloth, and then apply grease. After greasing, wipe off any excess grease.

8*4

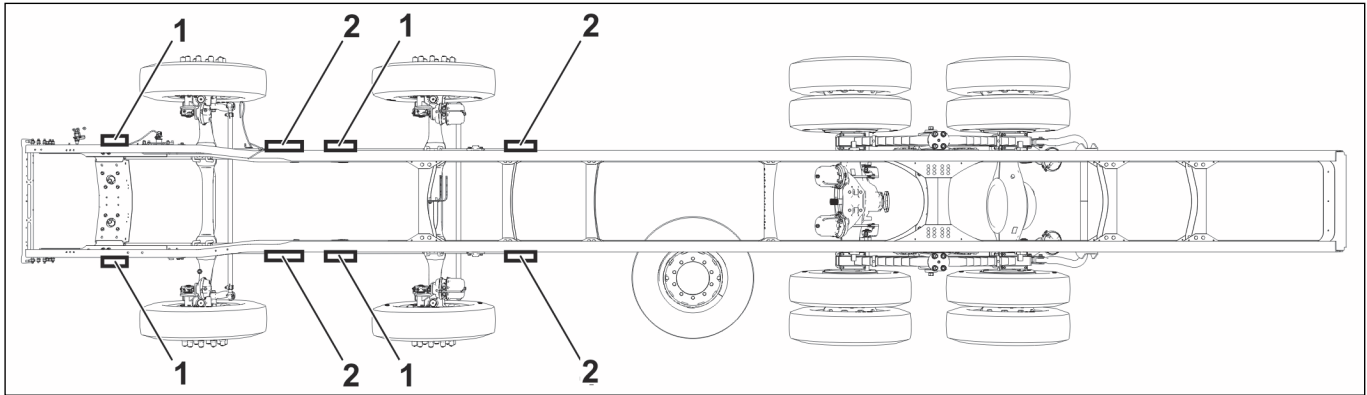

1. Spring pin
2. Spring pin and Shackle pins

8.INSPECTION AND MAINTENANCE

6*2 and 6*4

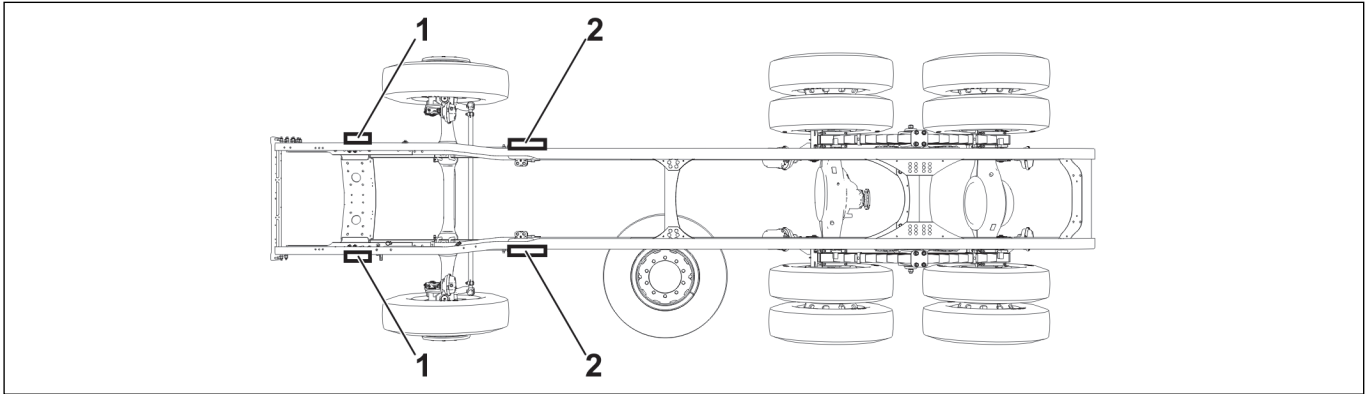

1. Spring pin
2. Spring pin and Shackle pins

4*2

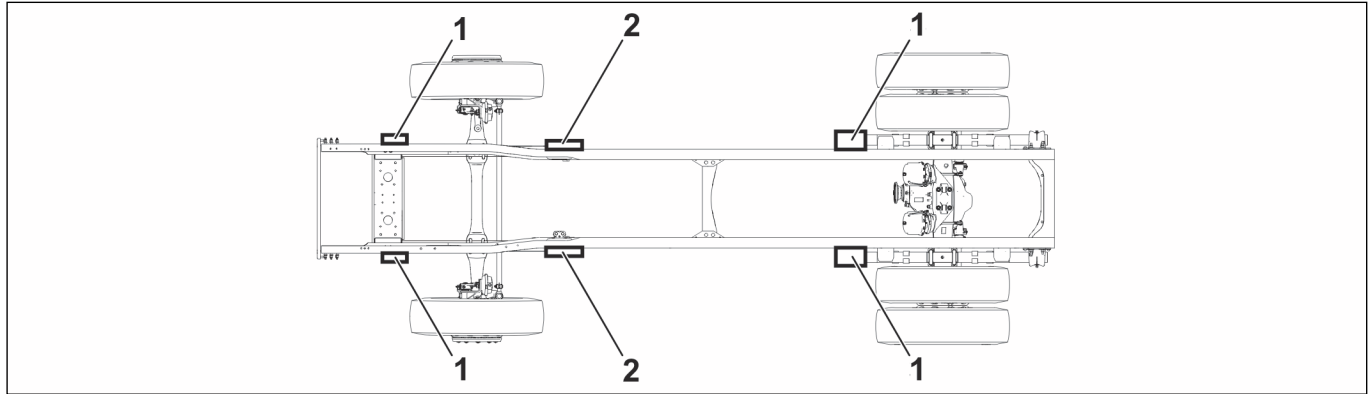

1. Spring pin
2. Spring pin and Shackle pins

THIS PAGE HAS BEEN LEFT
BLANK INTENTIONALLY

9.MAINTENANCE SCHEDULE

9.1 Overview

It is the owners responsibility to see that the vehicle receives proper care and maintenance.

Scheduled maintenance services beyond 60000 km or 12 months should be continued at the same intervals as before except the initial maintenance.

Under the following severe operating condition more frequent servicing will be required

- Operation in heavy dust conduction
- Extended high speed operation with vehicle fully loaded to its GVW
- Extended low speed operation
- Frequent stop and go operation,

Any replacement parts used for required maintenance service or repairs should be **UD** Genuine Parts.

A maintenance programme is provided with the purchase of the truck. The programme is based on vehicle type, driving conditions, oil grades, etc. and is unique to each truck. If the conditions that applied when the maintenance programme was developed have changed then the maintenance programme must also be changed.

The oil change at first service,

1. Transmission oil
2. Rear axle oil

For complete information on the lubrication points, oils and fluids, service intervals and service contract, please contact your **UD Trucks** authorised dealer.

9.MAINTENANCE SCHEDULE

Torque tightening intervals

Items		First	Torque tightening intervals											Remarks
	Kilometers x 1000	5	10	15	20	25	30	35	40	45	50	55	60	
	Months	1	2	3	4	5	6	7	8	9	10	11	12	
SUSPENSION FRONT														
U-bolt and nut							T						T	
SUSPENSION REAR														
U-bolt and nut							T						T	
U-bolt on rear axle suspension bracket							T						T	

Grease lubrication

For complete lubrication points and intervals refer to maintenance programme provided with the purchase of the truck or contact your nearest UD Trucks authorised dealer.

THIS PAGE HAS BEEN LEFT
BLANK INTENTIONALLY

10.EMERGENCY PROCEDURES

10.1 When there is problem

Precautions for failure

- During a breakdown situation do not panic, pay attention to the subsequent vehicles, slow down the speed gradually and stop the vehicle in a safe location free from traffic.
- It is dangerous to stop the vehicle in a tunnel. Stop the vehicle outside the tunnel.
- In case the vehicle stops in the middle of the road and it is difficult to move it to a safe place. Switch on the hazard lights and get down from the vehicle carefully and setup warning indications around the vehicle to warn the traffic.
- Place the warning indications signs around the vehicle to indicate the breakdown. If not subsequent vehicles may collide into the rear. Be sure to put signs of vehicle breakdown according to the methods below.
 - Stop indicator
 - Switch on the hazard light (emergency flashing light)
 - Place the emergency signal tool (signal light or safety flare) around the vehicle.
 - Place a red flag or red light around the vehicle.
 - Place the warning indication in a location where it is visible for other vehicles.
- Check the failure area. If it can be repaired, repair the vehicle while paying attention to other traffic.
- If it cannot be repaired, contact the nearest **UD Trucks** authorised dealer.
- For repairs involving with a jack on the road, the jack may be dislocated due to wind pressure of other vehicles. Never get under the vehicle when repairing. Always place the jack in a firm ground.

10.EMERGENCY PROCEDURES

Manual release of parking brake

WARNING

- Do not release the parking brake manually, if the vehicle stops on a slope.
- Do not perform manual release except for emergency movement of the vehicle or towing with a tow vehicle.
- If the vehicle stops with the spring brake, failure of the brake system may be possible. Have it inspected by the nearest UD Trucks authorised dealer.

Manual release procedure

1. Block the wheels to prevent the vehicle from moving.
2. Release the release nut by turning it anti-clockwise (Do not use impact wrench).

3. To ensure the compression spring is fully caged, the stud length should be approximately 75 mm.

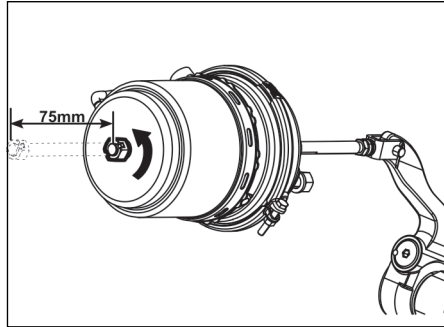

CAUTION

The release nut is secured on the release bolt with the knock pin. Do not remove the knock pin. Otherwise the parking brake cannot be released.

Towing

WARNING

If the engine does not start, tow the vehicle using a tow vehicle only. If the engine does not start, the brake and power steering will not work.

CAUTION

- For towing, be sure to disconnect the propeller shaft. Towing with the propeller shaft will lead to transmission failure.
- If the vehicle accidentally falls into ditch or trench, do not use the tow pin to pull the vehicle out. Contact UD Trucks authorised dealer for support.

Method to use tow brace

1. Remove the cap.

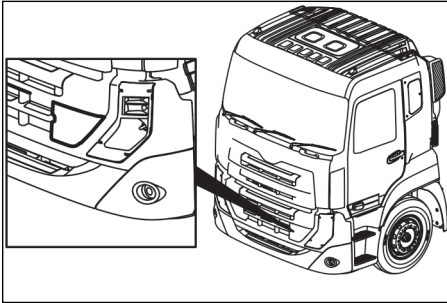

2. Remove the tow pin.

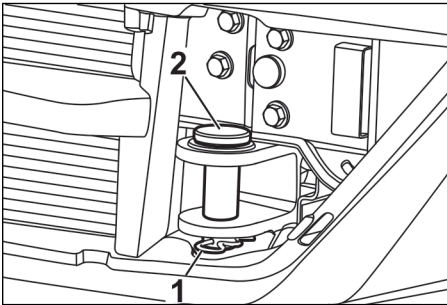

1. Safety pin
2. Tow pin

3. Install tow brace with tow pin.

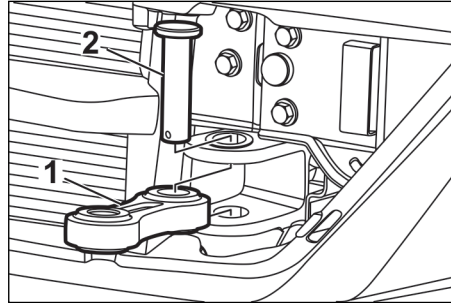

1. Tow pin
2. Tow brace

4. Secure the tow pin with safety pin.

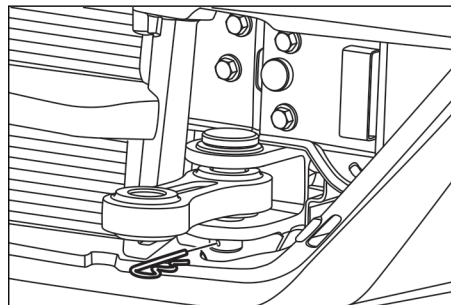

Towing precautions

Do's

- Always chock the wheels, before releasing parking brake.
- Disconnect propeller shaft before towing.
- Always use tow hook and tow rod for towing the truck.
- Lift the bogie axle up (if provided) before towing.
- If possible tow the vehicle with engine running.
- Follow local regulations while towing.

Don't's

- Do not tow using the under run protection devices.
- Do not use steel cable or chains for towing.
- Avoid towing vehicle at an angle.

10.EMERGENCY PROCEDURES

If flat tyre or burst tyre occurs while driving

DANGER

Do not drive with a flat tyre, the flat tyre will overheat and result in an accident. Replace the tyre immediately.

- Hold the steering wheel securely and press the brake slowly to decrease the speed gradually.
- Turn on the hazard light to alert subsequent vehicles and stop the vehicle in a safe location for changing the tyre.
- For changing a tyre, *Refer Chapter 8.*

NOTE

To park the vehicle select a location that is legal, safe, and will not interfere with traffic.

10.2 Jump start

Precautions for jump start

WARNING

- Do not place or bring to contact any metal with the positive (+) terminal of either vehicles.
- Check the jumper cable for wear out or damage in insulation.
- Check the battery fluid level before connecting the jumper cable. If charging is performed when the battery fluid level low, the battery may be deteriorated, heat up or explode. Perform charging after replenishing the fluid.

DANGER

Never do a tow start for starting the engine. Failure to comply can lead to accidents.

NOTE

If the battery is frozen or ice is found on the cell, do not start the vehicle with jumper cables.

When jump starting the engine using a jumper cable, spark might occur when the jumper cable is connected. Be sure to observe the following steps.

Be sure to use a large capacity jumper cable for the large vehicle. For the correct jumper cable, ask the nearest **UD Trucks** authorised dealer.

- Stop the engine of the vehicle that is supplying the power.
- Connect the positive end of the jumper cable (red) to the positive (+) terminal of the discharged battery and the other end to the positive (+) terminal of the good battery.

- Connect the negative end of another jumper cable (black) to the negative (-) terminal of the good battery and the other end to the body frame of the vehicle with the discharged battery where the position is as distant as possible from the battery.
- After connecting the jumper cable, start the engine of the vehicle with the discharged battery. If it is difficult to start the engine in a cold region, start the engine of the vehicle that supplies the battery power, and wait for several minutes before starting the engine of the vehicle with the discharged battery
- After starting the engine, disconnect the jumper cables in the reverse order of connection.
- Use heavy-duty jumper cables for large vehicles.
- Ensure that the total voltage of the auxiliary batteries is 24 V.

10.EMERGENCY PROCEDURES

- If the auxiliary batteries are in another vehicle, switch OFF the engine of that vehicle and ensure that the two vehicles are not in contact with each other
- Pay attention to the connection order when drawing power from a vehicle with a normal battery. The sparks generated during connection could cause a serious accident.

11.SERVICE DATA

11.1 Maintenance standard

For more information on the items below contact your **UD Trucks** authorised dealer.

Item		Maintenance standard	Remarks	
Chassis	Wheel alignment	Toe-in	1 mm at axle free condition	
		Camber	0° 42'	
		Caster	3° 30'	
	Turning angle (inside X Outside)		49° X 34.5°	FAA 10
			44.5° X 33°	FAA 20
	Tyre pressure		Refer to tyre manufacturer's specification	
	Tyre tread groove depth		Marking on wheel	As per supplier information
	Wheel nut		650 ± 75 N.m (66.28 ± 7.64 Kgf.m)	

11.SERVICE DATA

Recommended lubricants

Lubricant		Grade/Standard	UD lubricants
Engine oil		VDS-3	UD Engine Oil Mega Multi 3 SAE 15W-40
		VDS-4	UD Engine Oil Mega Multi 4 SAE 15W-40
Gear oil	Transmission	API GL-4	UD Genuine Gear Oil GL-4 80W-90
Axle oil	Single reduction	API GL-5	UD Genuine Rear Axle Oil GL-5 85W-140
	Hub reduction		
Power steering fluid		ATF Dexron III	-
Grease	Bearing grease	Lithium based grease of consistency NLGI No. 2	-
Clutch fluid		DOT- 4	-
Engine coolant		VCS (Yellow liquid)	UD Long Life Premix

Capacities (approximately)

Title	Engine	Engine total oil volume inclusive approximate volume for oil filter (liters)	Oil volume between dipstick Max - Min (liters)	Remarks
Engine oil	GH11E	37.5	5	

Title	Engine	Capacity (liters)	Remarks
Engine coolant	GH11E	49.5	Only a guide line as this varies dependent on vehicle installation and equipment

Title	Variant	Capacity (liters)	Remarks
Power steering system fluid	FAA10	4	4x2, 6x2, 6x4
	FAA20	6	8x4

11.SERVICE DATA

Title		Variant (Model)	Gearbox Standard oil volume (liters)	Gearbox with oil cooler oil volume (liters)	Gear box with PTO oil volume (liters)	Gear box with PTO and oil cooler oil volume (liters)
Transmission	6 Speed	ST1306 (F6S13T)	11.5	11.6	12.5	12.6
		ST1006 (F6S10T)	11.5	11.6	12.5	12.6
	9 Speed	STO2009 (F9R20A)	14	14.8	15	15.8
		ST1509 (F9R15T)	13	13.1	14	14.1
		ST1199 (F9R11T)	13	13.1	14	14.1
	12 Speed	STO2012 (F2R20A)	15	15.8	16	16.8

Title		Variant	Capacity (liters)
Axle	Single reduction	RSS1348 Single reduction solo axle	17
		RTS2670 Foremost axle	19
		RTS2670 Rear most axle	16
	Hub reduction	RTH2611 Foremost axle	34
		RTH2611 Rear most axle	29.5

Note: Capacities shown are for reference only. When filling, observe the specified level with respect to the vehicle.

Recommended SAE viscosity number

Use oil with the right viscosity value that suits the climatic condition of the area being operated.

Engine oil

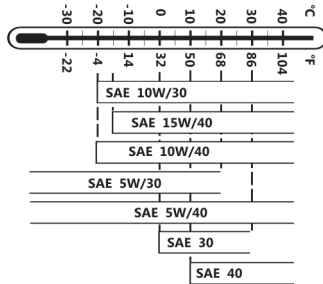

Gearbox oil.

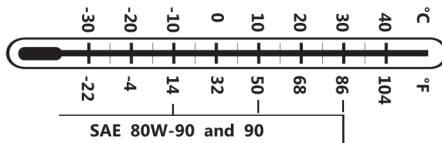

11.SERVICE DATA

Axle oil.

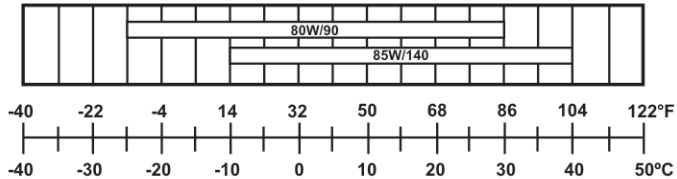

Grease quality

Requirements for lubricating grease are as follows.

- High grade wheel bearing grease should be used.
- The grease should be mineral oil based.
- The grease should be lithium or lithium complex type.
- The grease should contain EP and anti-rust additives.
- The grease must have a consistency equivalent to NLGI no. 2.
- The grease should not contain any solid lubricants, such as graphite, copper or molybdenum sulphide.
- The grease must be intended for use in working temperatures of at least 80° C and be able to withstand 120° C for short periods.

Diesel fuel

Fuel composition plays an important role in engine function, service life and emission pattern. In order to achieve specified performance in terms of power output and fuel economy, and to meet the emission requirements that the authorities set, you must only use fuels that fulfil legal requirements and national and international standards. These standards represent the minimum requirement for market fuels, and they are usually developed in cooperation with the oil companies and the automotive industry. Examples are

- GB 19147-2013
- EN590 (with nationally adapted cold requirements)
- JIS KK 2204

Most of the fuel sulphur is converted into sulphur dioxide (SO₂) in the combustion process, this SO₂ is later transformed into sulphuric acid in the atmosphere and contributes to acid rain.

The particulate (PM) emissions increase with increasing sulphur content. Vehicles fitted with exhaust after-treatment systems (for instance particulate filters, oxidation catalysts) are particularly sensitive to sulphur.

Maximum sulphur content for fulfilling the different emissions levels

Euro III: max 350 ppm

Euro IV/China IV: max 10/50 ppm

To ensure that the emission requirements are met in a durable way in service for Euro IV/China IV vehicles, sulphur free fuels (<10 ppm) are recommended.

In no case should the sulphur content exceed 50 ppm.

11.SERVICE DATA

Fifth wheel

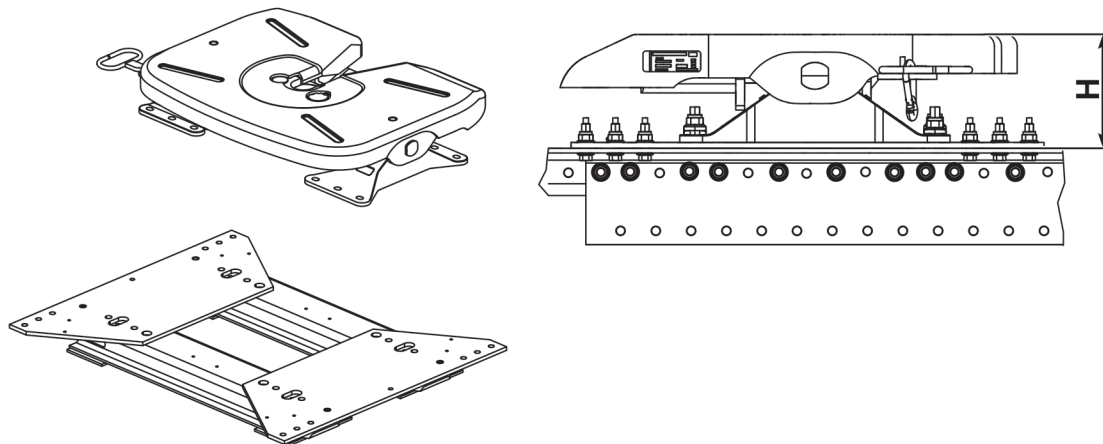

Variant.	Fifth wheel Model No.	D-value	King pin size	Max vertical load	Fifth wheel height "H"
KPSIZE50	FW20-150	150 kN	50 mm	20 tonne	150 mm
	FW20-185	150 kN	50 mm	20 tonne	185 mm
KPSIZE90	FW28-150	190 kN	90 mm	28 tonne	150 mm
	FW28-185	190 kN	90 mm	28 tonne	185 mm

The D value is the theoretical reference value for the horizontal forces in the towing vehicle and the trailer and is used as the basis for horizontal loads in the dynamic tests.

Engine specification

Designation	GH11E - D11A 370 EU3 GH11E - D11B370, EU4SCR	GH11E- D11A390 EU3 GH11E - D11B390, EU4SCR	GH11E - D11A420 EU3 GH11E - D11B420, EU4SCR
Power net	370 hp (1900 rpm) 370 hp (1800 rpm)	390 hp (1900 rpm) 390 hp (1800 rpm)	420 hp (1900 rpm) 420 hp (1800 rpm)
Torque net	1700 Nm (1000 - 1400 rpm) 1700 Nm (950 - 1400 rpm)	1800 Nm (1000 - 1400 rpm) 1800 Nm (950 - 1400 rpm)	2000 Nm (1000 - 1400 rpm) 2000 Nm (950 - 1400 rpm)
No. of cylinders	6	6	6
Diameter of cylinder	123 mm	123 mm	123 mm
Stroke	152 mm	152 mm	152 mm
Piston displacement	10.837 l	10.837 l	10.837 l
Compression ratio	18:1 17.1:1	18:1 17.1:1	18:1 17.1:1
Firing sequence	1 - 5 - 3 - 6 - 2 - 4	1 - 5 - 3 - 6 - 2 - 4	1 - 5 - 3 - 6 - 2 - 4
Auxiliary brake	EPG/UD EEB	EPG/UD EEB	EPG/UD EEB
Engine speed at idle	600 rpm	600 rpm	600 rpm
Economical engine speed range	900 - 1400 rpm	900 - 1400 rpm	900 - 1400 rpm

11.SERVICE DATA

Electrical system-24 Volts

SI No.	Description	Category	Specification
1	Bulb- Head lamp U/D Lamp	H4	75/70W
2	Bulb- Front direction indicator lamp	PY21W	21W
3	Bulb- Front position lamp	W5W	5W
4	Bulb- Front end-out marker lamp	W5W	5W
5	Bulb- Front fog lamp	H3	70W
6	Bulb-Side marker lamp with tail lamp	R5W	5W
7	Bulb-Side marker lamp without tail lamp	W5W	5W
8	Bulb- Side direction indicator lamp	P21W	21W
9	Bulb- Rear position lamp	P21/5W	21/5W
10	Bulb- Stop lamp	P21/5W	21/5W
11	Bulb- Rear direction lamp	PY21W	21W
12	Bulb-Reversing lamp	P21W	21W
13	Bulb- Rear fog lamp	P21W	21W
14	Bulb- Rear end out marker lamp	R5W	5W
15	Bulb- Rear registration plate lamp	R10W	10W
16	Shelf lamp	C5W	5W
17	Cabin interior lamp	R10W	10W
18	Work lamp	H370W	70W

UD Trucks Corporation

1-1, Ageo-shi, Saitama 362-8523, Japan

Pub. No. 22336671