



Section

1A

Air and Electrical Systems

Version - Rev (2.3)

Air & Electrical Systems – Section #1A

Harness Information	1A-1
Dash Mount Navigation/Camera Prep New	1A-2
Cutoff Switches	1A-3
Power Net Distribution Box (PNDB)	1A-4
Power Distribution Module (PNDB)	1A-5
RX Module	1A-6
2007 Star Gauges	1A-7
2010 Star Gauges	1A-8
2010 J1939 Connections	1A-9
Fuse & Relay Blocks	1A-10
In Cab Body Builder Connections 4700 with PDM	1A-11
4700 Cab Electrical Pass Through Details	1A-12
Additional Switch Package	1A-13
Optional Switch Types	1A-14
Optional Switch Facings	1A-17
WST Air System	1A-18
Air Line Numbering	1A-20
Air System - In Cab Schematic All LHD	1A-21
Utility Lights	1A-22
Lighting Modifications	1A-23
WST Tail Light Configurations 48/49/6900	1A-25
WST Tail Light Configurations 4700	1A-26

This guide is to be used as a reference document only. Please consult your Western Star CAE representative on specific spec'ing needs as the information contained in this document can change without notice.



Electrical Overview

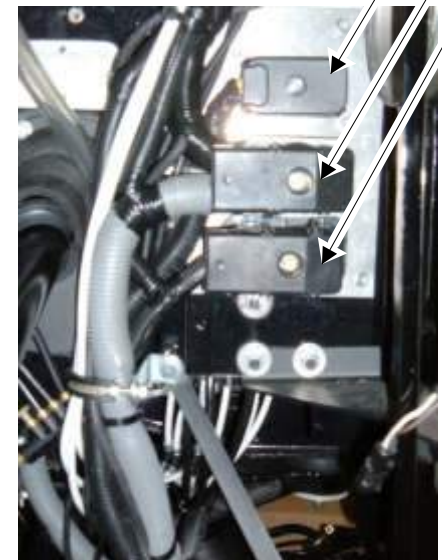

Engine and ABS
 Front Wall/ Sleeper
 Main Chassis
 Harness

TRANSMISSION

MAIN CAB HARNESS
 MODULE
320

WIRING
 MODULE
34B
 TRANSFER CASE
 MODULE
376
 AUXILIARY
 TRANSMISSION
 MODULE
34C / 352

EOF LIGHTING
MOD 294

AXLE
 WIRING
 INTERLOCK
MOD 87B
 AXLE TEMP
MOD 865

FRONTWALL
 HARNESS
MOD 321

ENGINE HARNESS
 MODULE
286 / 283

LIGHTING
 EXT. LIGHTS
MOD 318 / 31J
 BEACON
 LIGHTS
MOD 327
 FORWARD
 CHASSIS &
 SIGNAL
312 / 314
315 / 310

MAIN CHASSIS
 HARNESS
MOD 288

Power Net Distribution
 Box (PNDB)

TRAILER
 WIRING
 PRIMARY
 TRAILER CBL
MOD 296
 ADDITIONAL
 PRIMARY
MOD 303
 SUPPLEMENTAL
 CABLE
MOD 308
 ADDITIONAL
 SUPPLEMENTAL
MOD 334
 PTO
MOD 372 / 885

POWER WIRING
 ALTERNATOR
 ROUTINGS
MOD 125
 BATTERY
 CABLES
MOD 291
 POWER
 WIRING
MOD 29A
 JUMPSTART
MOD 295
 CAB POWER
MOD 926
 BATT
 SHUTOFF
MOD 293



Dash Mount Device Prep

1U1-001 TOP OF DASH NAVIGATION PREP WITH POWER AND GROUND

Dash Mount Device Prep

Western Star now offers a Top dash mount Navigation Prep. This new option provides a standard bolt pattern in the dash for a 1" RAM ball mount system or other camera mount equipment. These mountings allow customers to quickly mount a variety of electrical devices ranging from navigation systems to cell phone holders in a road legal and easily accessible location without drilling the dash. Mounting solutions for most devices can be found on the RAM website. Navigation and Camera systems can be consistently mounted to factory installed mounts with no cab modifications. This industry leading solution allows customers to easily upgrade to new systems as fast as they become available to the market. The Nav prep system is superior to in dash navigation as it allows owners or drivers to easily add their own devices such as iPhones for hands free and navigation or full navigation and backup systems. Today's technology is moving quicker than in dash systems can keep up with. Using the Western Star Navigation prep your equipment can be easily upgraded to the latest hardware in minutes.

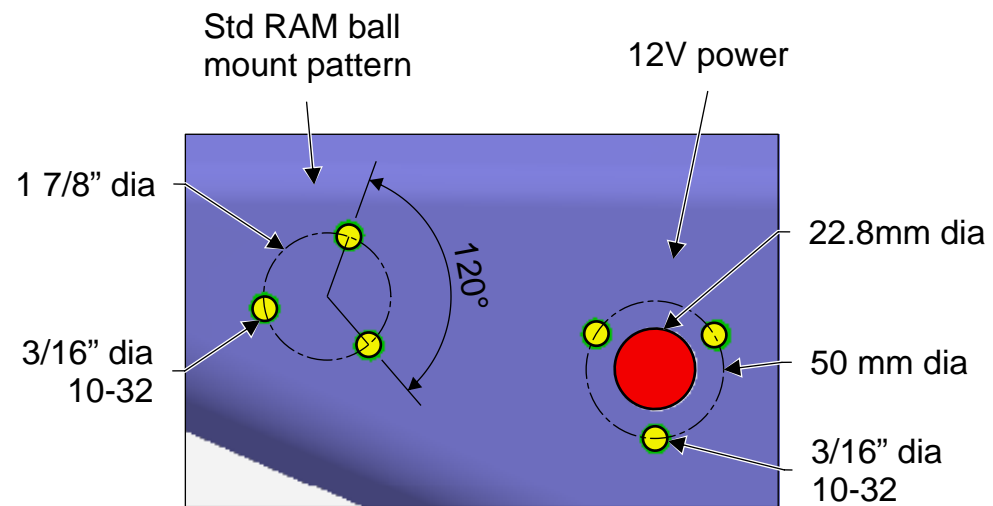

AWTI Camera Mounted using common mounting pattern



Nav System Mounted using RAM Mounting Adapters Shown Below

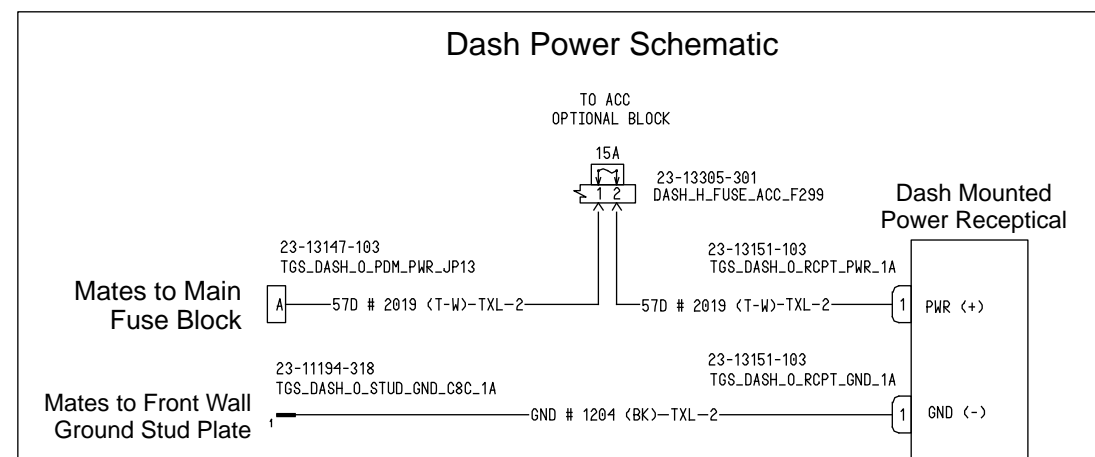

RAM B-201CHU



RAM B-202CHU



RAM B-201



RAM B-202U



Top of Dash Mount Navigation Prep

Positive Disconnect Switch

The disconnect switch system for 2010 has been reconfigured to provide better application coverage and provide for two levels of power disconnect based on the options ordered with the truck.

In-cab disconnect switches are offered in “locking” or “non-locking” configuration.

Exterior battery mounted switches will be offered in the locking configuration only.

Cutoff switches are equipped with red LED lights, which are illuminated when power is on.

Trucks equipped with the body builder auxiliary power system will have an additional LED light on the switch.

Note:

1. Both PNDB units will be deactivated when the switch is in the off position.
2. Positive disconnect switches do not isolate the starter.

Negative Disconnect Switch

The negative disconnect switch option is for use in emergency and dangerous goods applications only. This option provides a battery box disconnect between the starter and the batteries. This option is currently only available with Detroit Diesel engine configurations

293-058	POSITIVE LOAD DISCONNECT W/CAB MOUNTED CONTROL SWITCH MOUNTED OUTBOARD DR SEAT
293-060	POSITIVE LOAD DISCONNECT W/CAB MTD CONTROL SW W/LOCKING PROVISION MOUNTED OUTBOARD DR SEAT
293-061	POSITIVE LOAD DISCONNECT W/BATTERY BOX CONTROL SWITCH WITH LOCKING PROVISION
293-057	NEGATIVE LOAD DISCONNECT FOR DDC ENGINES WITH BATTERY BOX DISCONNECT SWITCH



293-058/-060/-061 Positive Disconnect Switch

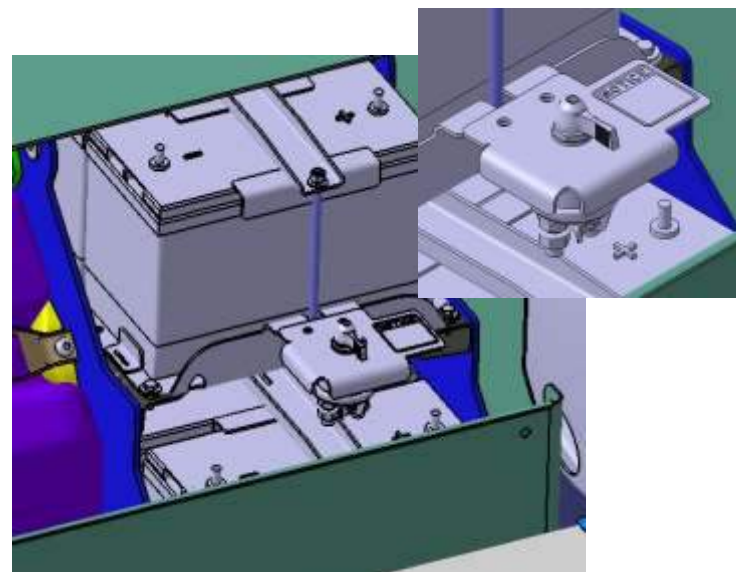

293-057 Negative Battery Box Switch

Main Cab PNDB
Connector Plug
#23-13153-307

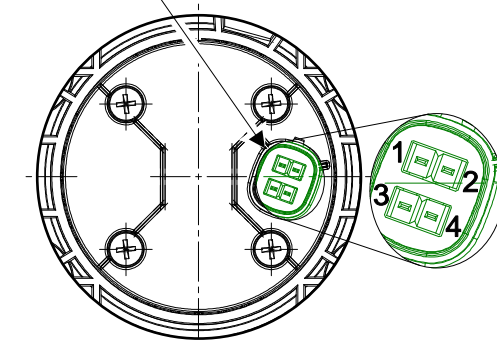

CONNECTOR	PIN	DESCRIPTION
X1, Main PNDB	1	ON SIGNAL
	2	RETURN SIGNAL
	3	LED INDICATOR
	4	OFF SIGNAL

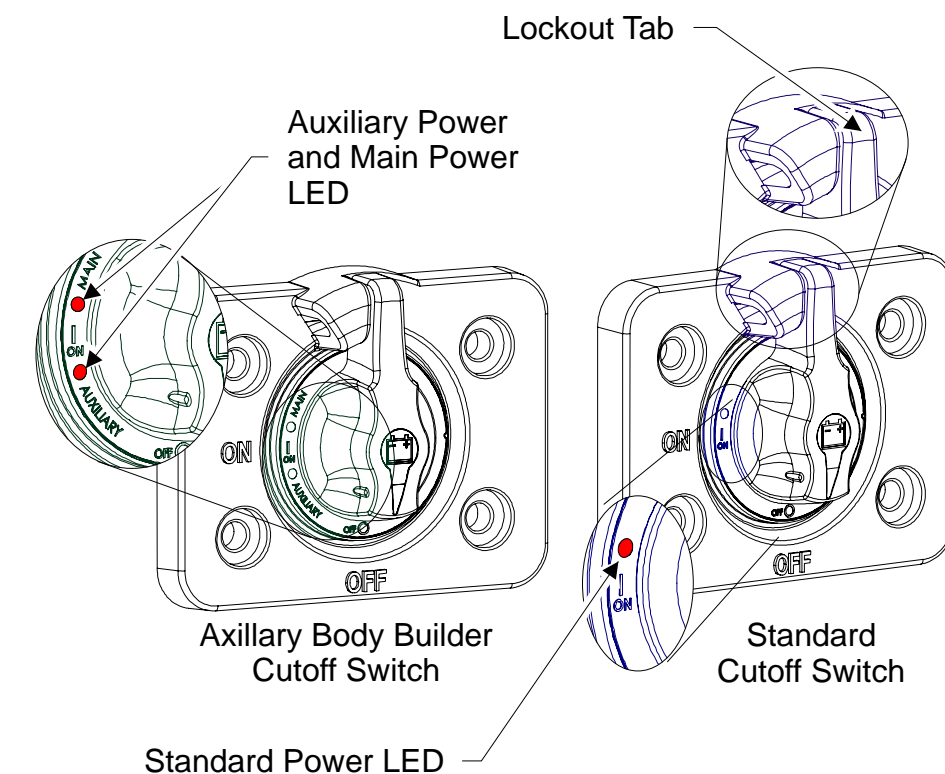



PNDB Power Net Distribution Box

Power Net Distribution Box (PNDB)

The PNDB is a new power delivery system for the WST and is designed to deliver more consistent and better protected battery power to the other components on the truck.

The PNDB also has protected "keep alive" circuits that will maintain power even with the cutoff switch in the off position. The primary reason for this change is to provide power to the 2010 DEF purge system which drains urea from the delivery system and prevents the system from freezing during cold conditions.

The PNDB located at the lower LH front wall area is equipped with three MIDI fuses which supply power to the Main Power Distribution Module. These fuse connections have been relocated from the battery in 2010 to prevent corrosion and improve the trucks reliability in severe conditions.

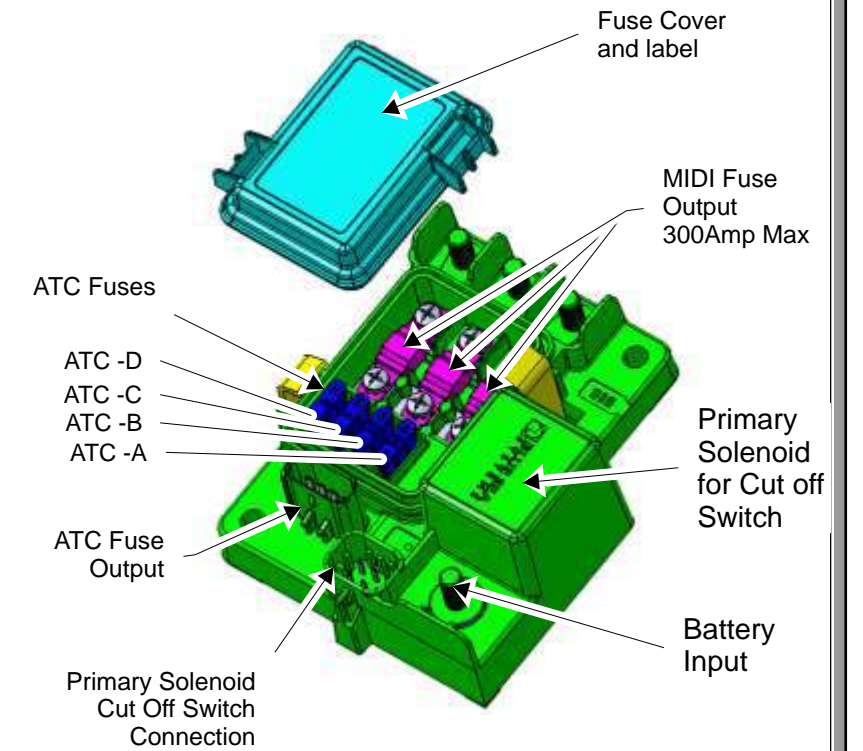
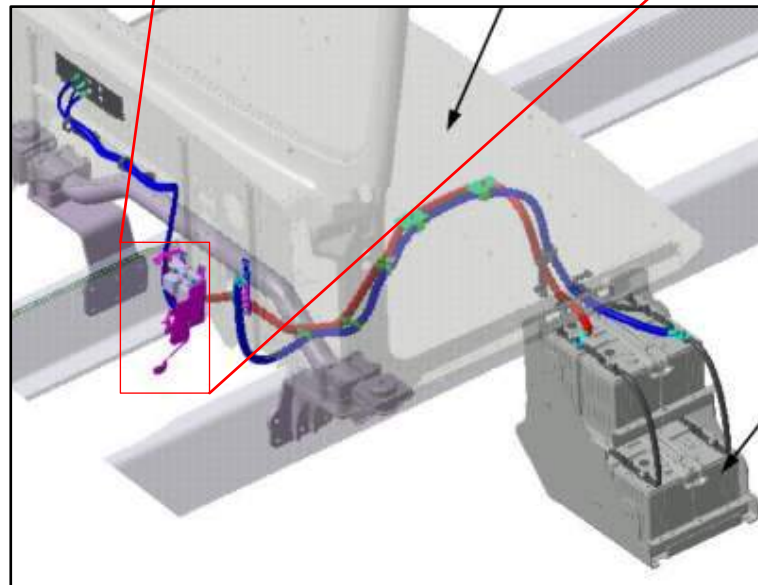
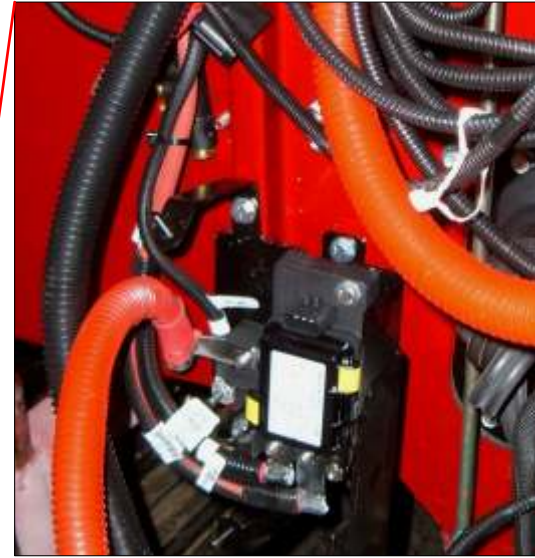

CONNECTOR	PIN	DESCRIPTION
X2 KEEP ALIVE CIRCUIT	1	AFTER TREATMENT ECU
	2	EMERGENCY POWER
	3	RADIO AND CLOCK
	4	ALTERNATOR REMOTE SENSE
X1 Disconnect through solenoid control	A	GROUND
	B	SIGNAL OFF
	C	LED INDICATOR
	D	SIGNAL ON
	E	SIGNAL RETURN
	F	GROUND

Fuse	Description	Function	Rating	Max. Fuse Allowed
ATC-A	Keep Alive Power	After Treatment ECU	30 AMPS	30 AMPS
ATC-B	Keep Alive Power	Emergency Power	20 AMPS	30 AMPS
ATC-C	Keep Alive Power	Radio and Clock	5 AMPS	30 AMPS
ATC-D	Keep Alive Power	Alternator Remote Sense	5 AMPS	30 AMPS
MIDI-1 (Fuse 1)	High AMP Fuse		175 AMPS	200 AMPS
MIDI-2 (Fuse 2)	High AMP Fuse		125 AMPS	200 AMPS
MIDI-3 (Fuse 3)	High AMP Fuse		125 AMPS	200 AMPS

INSTALLATION WITHOUT DISCONNECT SWITCH

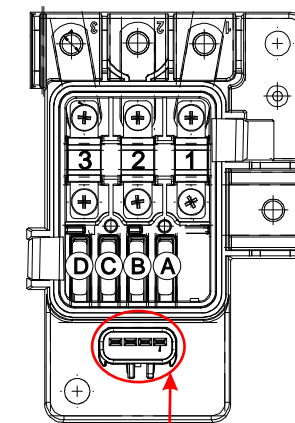

INSTALLATION WITH DISCONNECT SWITCH

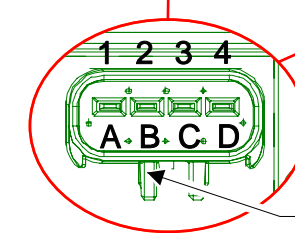
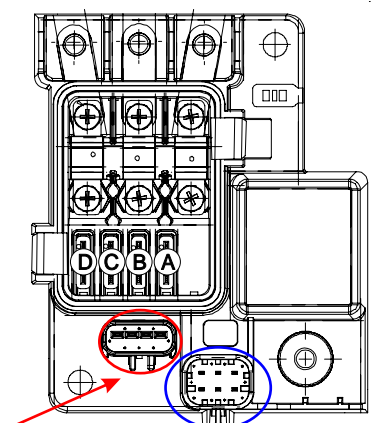

X2
ATC Fuse output
keeps power on
after disconnect

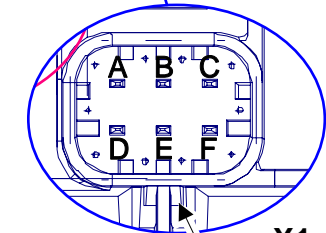

X1
Solenoid
Control

Mating connector
23-13153-410



Power Train – Power Distribution Module (PT-PDM) Module 286

Power Train (PT-PDM)

The PT-PDM holds all of the power train related fuses and relays.

- All engine fuses/relays
- All transmission fuses/relays
- All after treatment fuses/relays except DCU main battery feed (located in PNDB)
- Sleeper power

The power which supplies the PT-PDM is sourced from the Power Net Distribution Box (PNDB). This power is protected by a 175A fuse. It is important to note that the PNDB holds the bi-stable relay, which disconnects the battery when the relay is turned off power at the PNDB output. PT-PDM power is not maintained by the alternator if the disconnect switch is "thrown". therefore the engine ignition relay, in the PT-PDM will fall out and the engine will turn off.

The source of the ignition signal, on a WST, is Fuse F33_LD which is in the optional fuse block in the dash of the Western Star.

The sole purpose of this line is to turn on the PT-PDM relay which then powers ignition for all the engine related ignition circuits.

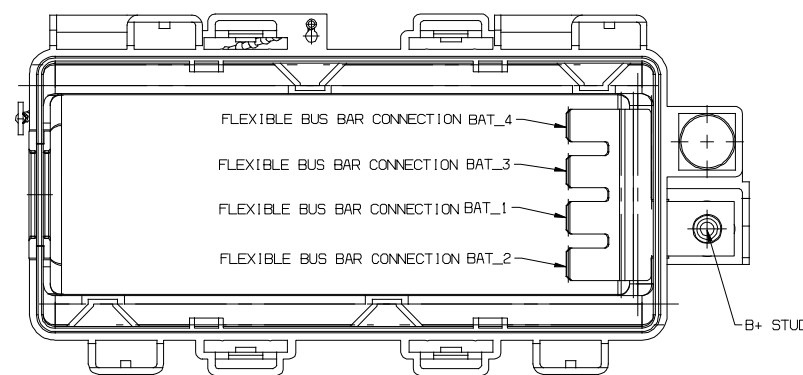

VIEW B
TOP COVER REMOVED FOR CLARITY

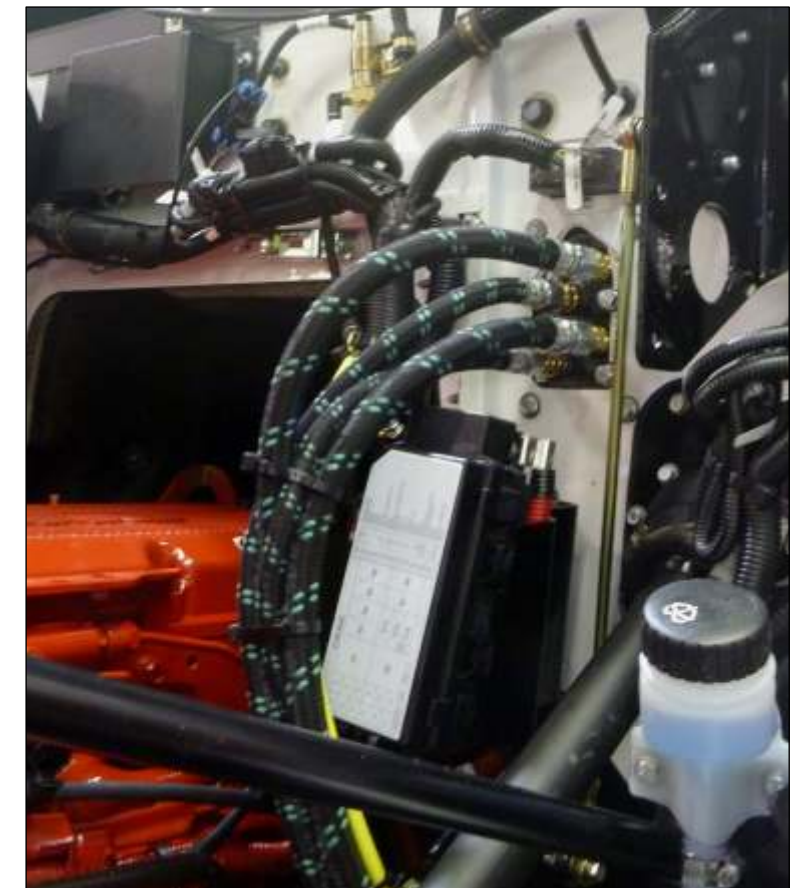
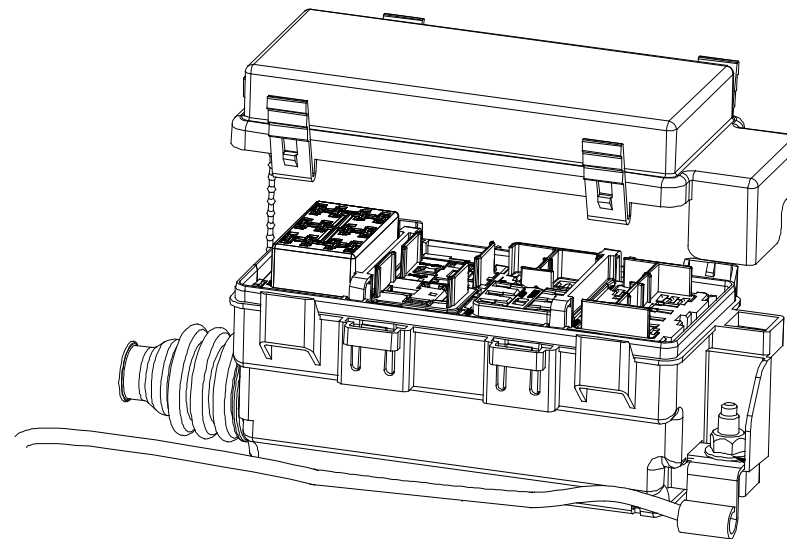



RX Module

WST Star Gauge System

Beginning in April 2005, the PX and PX-A modules were replaced by air lines that are routed to each individual Star Gauge. These gauges convert the air pressure into an electrical signal. The Star Gauge databus supplies power, ground, and backlighting information for these gauges.

Beginning with EPA10 vehicles, the engine controller no longer offers a J1587 databus. The engine, transmission, ABS, and most of the other optional electronic devices on the vehicle now communicate using J1939 protocol.

The EPA10 RX module

This new redesigned module, incorporates the functions of the earlier RX and PX modules in one unit that also performs a gateway function.

The EPA10 RX module performs the following functions.

- * Converts sensor and voltage inputs into J1587 (PI bus) data.
- * Converts four air pressure inputs into J1587 (PI bus) data.
- * Gateway Function converts J1939 data that is required for the DataStar and the Star Gauges into J1587 protocol (PI bus) data.

NOTE: The J1587 data network is also called the PI bus in some instances.

The speedometer uses the J1587 data from the RX module as the source of data for the Star Gauges.

The Datastar is also on the J1587 (PI bus) network and uses this data. The RX gateway module is located on the underside of the cab below the steering shaft, near the clutch linkage.

24 to 12 Volt Converter

The 24 to 12 volt converter is used on vehicles with 24 volt electrical systems. It is connected between the speedometer and the dash wiring harness and reduces voltage to 13.5 volts which is needed by the Stargauge and Datastar system

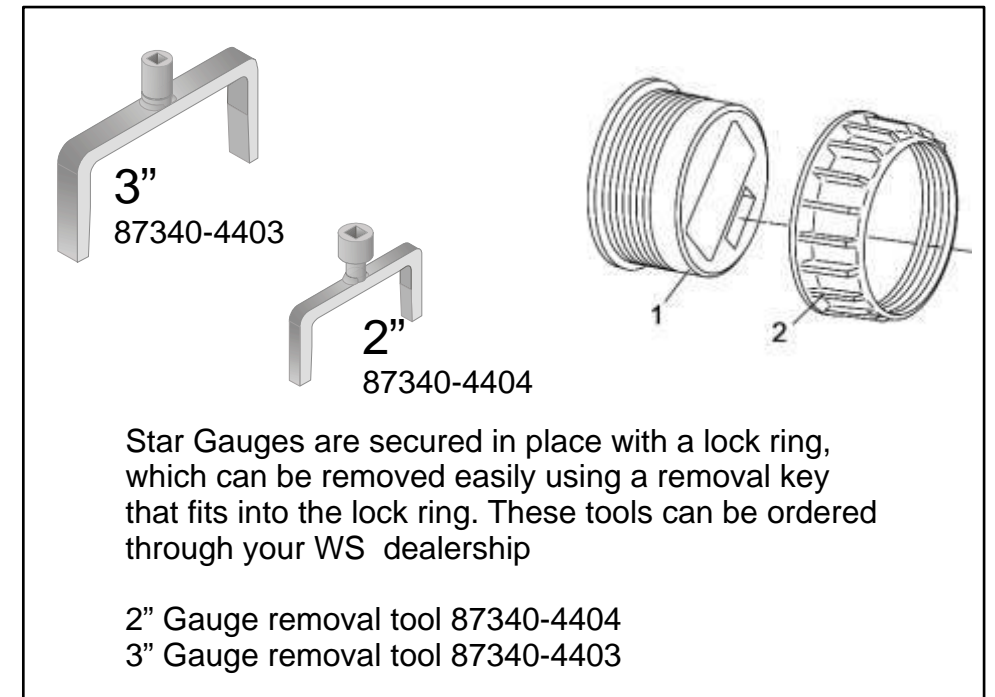



2007 Star Gauge System

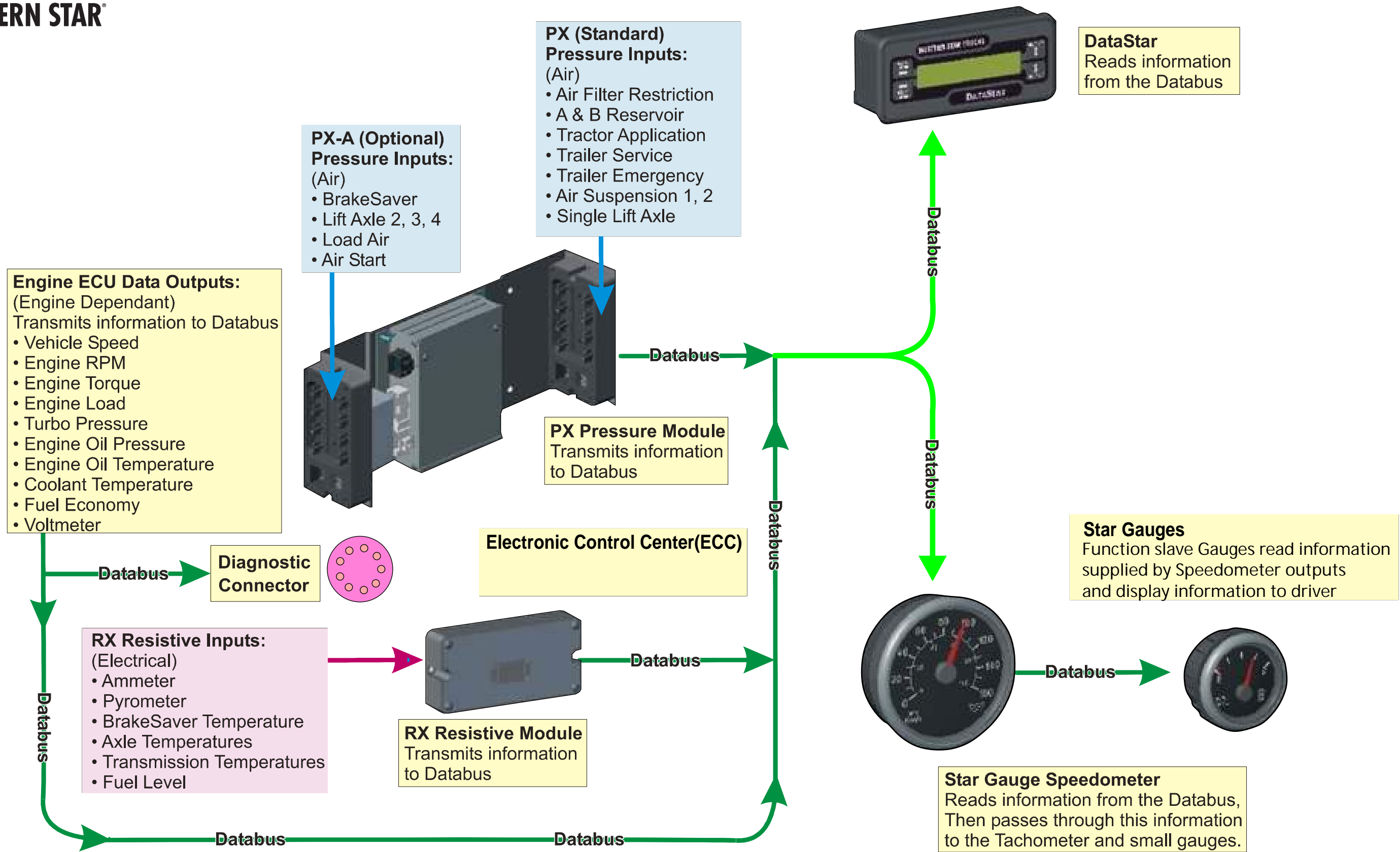



2010 Star Gauge System All LHD Models

Pressure Gauge Inputs:

- (Air)
- Air Filter Restriction
 - Trailer Service
 - Trailer Emergency
 - Air Suspension 1, 2
 - Single Lift Axle
 - BrakeSaver
 - Lift Axle 2, 3, 4
 - Load Air
 - Air Start

Star Gauge Speedometer

Reads information from the Databus, Then passes through this information to the Tachometer and small gauges.

Electrical Star Gauges

Function slave Gauges read information supplied by Speedometer outputs and display information to driver

Air-Line

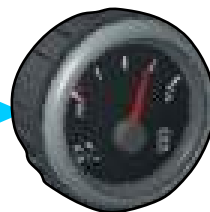

Air pressure Star Gauges

Air system components feed air pressure directly to designated air gauges in dash



Databus

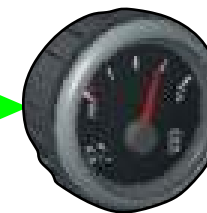

Engine ECU Data Outputs:

- (Engine Dependant)
Transmits information to Databus
- Vehicle Speed
 - Engine RPM
 - Engine Torque
 - Engine Load
 - Turbo Pressure
 - Engine Oil Pressure
 - Engine Oil Temperature
 - Coolant Temperature
 - Fuel Economy
 - Voltmeter



Databus



DataStar

Reads information from the Databus

Diagnostic Connector

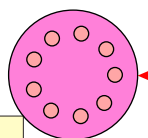

J1939

J1939

2010 Resistive (RX) Module

2010 RX Module acts as a gateway to convert J1939 engine and system inputs into WST Star Gauge databus signal



RX Resistive Inputs:

- (Electrical)
- Ammeter
 - Pyrometer
 - BrakeSaver Temperature
 - Axle Temperatures
 - Transmission Temperatures
 - Fuel Level

J1939

J1939

RX Pressure Inputs:

- (Air)
- A & B Reservoir
 - Tractor Application
 - Tractor Suspension

Air-Line

2010 J1939 Connection All LHD Models

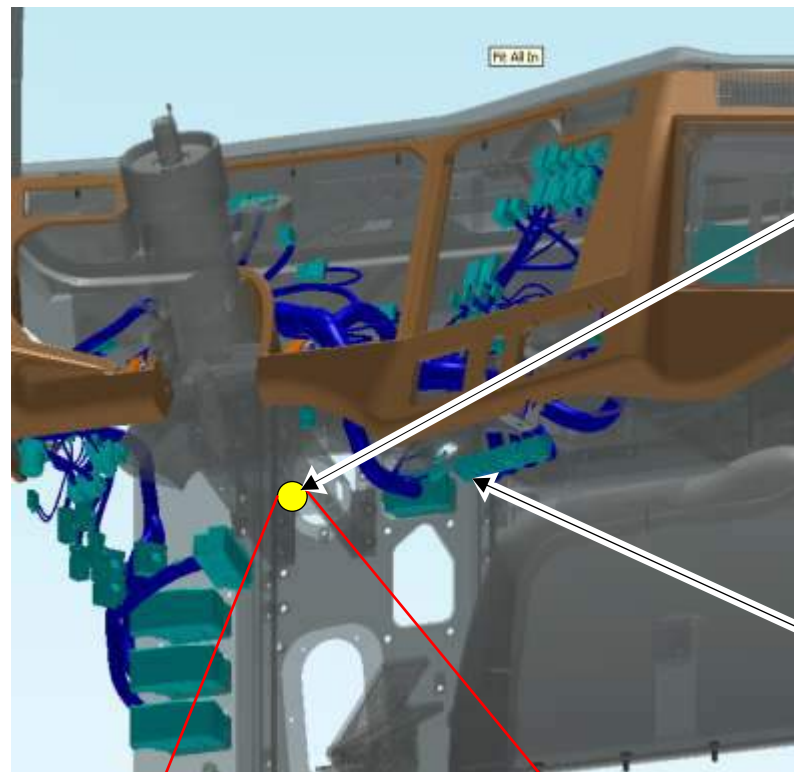

Cab resistor located in dash 10" back from frontwall engine connection

Front Wall Engine connection
40 pin 48/49/6900
76 pin 4700

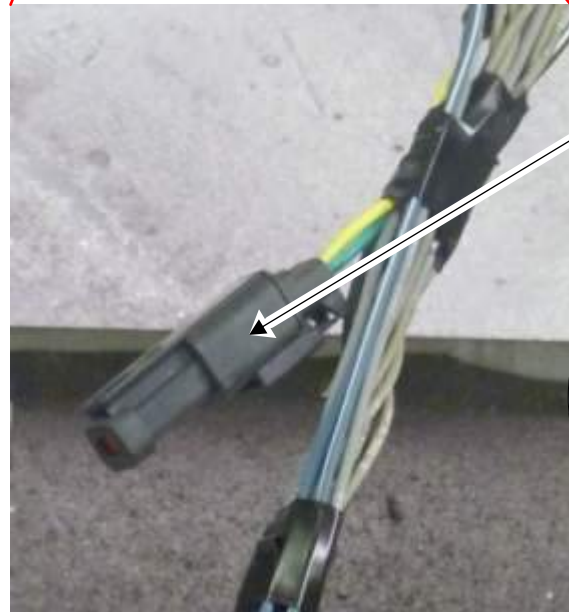

Resistor Receptor
Part FTL# 23-13303-902
Deutsch # DTM04 - 2P - EP10

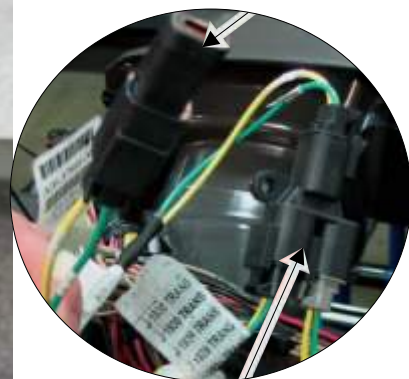

The J1939 Datalink

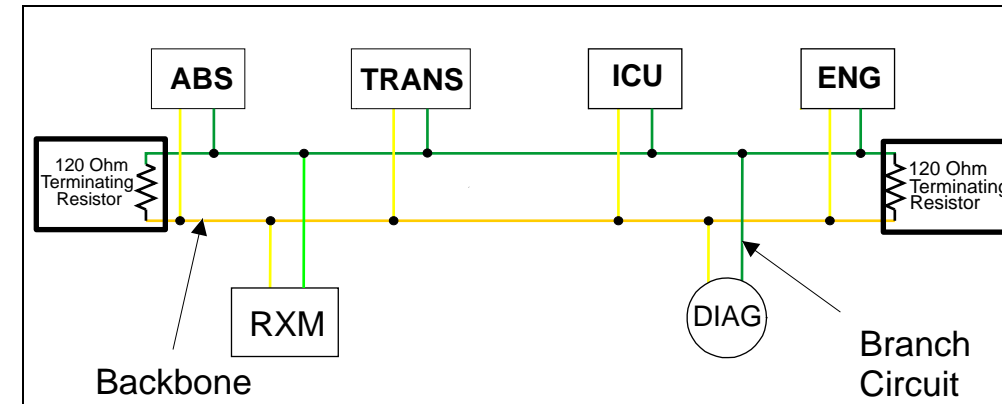

WST J1939 System Connections

J1939 Connections

Tying into the J1939 backbone is accomplished by tapping into the system using the terminating resistor tee's located at each end of the backbone

The Chassis terminating resistor is located in a tee along the left frame rail, usually behind the cab.

The cab terminating resistor is located in the dash tapped 10" back from the Front Wall engine plug harness under the dash (shown on the left). The correct datalink resistance measured at any device, or at the diagnostic plug should be 60 ohms with the battery disconnected.

IMPORTANT:

- It is essential that both terminating resistors remain connected to the ends of the J1939 backbone to dampen feedback signals. Numerous J1939 problems can be attributed to terminated resistors are missing or disconnected.
- If connections under dash become disconnected. Connections should never be reconnected back together directly IE ABS with ABS as this creates an independent circuit in the system that is not connected to the backbone.

J1939 Connections for Body Builders

To connect easily to J1939 at dash location order the following parts:

- (1) Tee and Jumper FTL# A06-37868-000
- (1) Jumper Plug # DUFDTM06 2S E004
- (2) Female Pins DUFWM2SB



Fuse and Relay Blocks

The WST Fuse panel is equipped with 30 fuses, 14 relays and 18 power jumpers. The fuse and relay locations are standard as shown but may be changed by engineering to accommodate new designs. Refer to the 'Main Cab Harness' schematic in Mod 320 to find the specific information on these items. The fuse panel jumper slots provide for 18 additional power jumpers; which provide power.

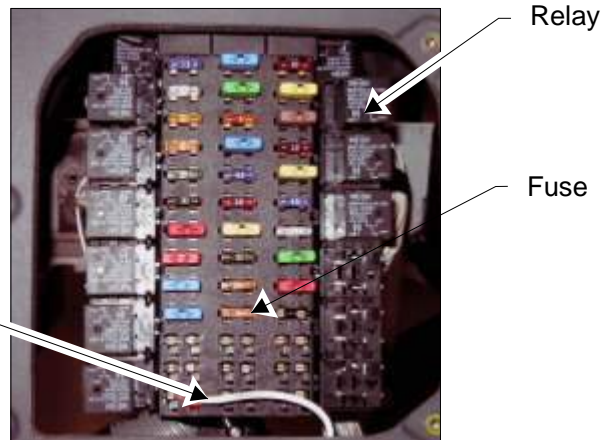

Main Fuse Panel

Jumper Harness used with optional Fuse Panel

Fuse Location	Fuze Rating	Wire Code LN	Function
F1	10A	BA3H-10	Start Switch
F2	20A	Bus Bar	Par Lights
F3	8A	BA03Y-10	Headlight Switch
F4	10A	BA03K-10	Radio
F5	20A	BA03N-10	ECC Flasher
F6	20A	BA03K-10	Interior Lights
F7	20A	BA03N-10	Wiper Motor
F8	30A	BA03U-10	Brake Light
F9	10A	BA25A-12	Electric Horn
F10	30A	BA03T-10	Option Battery Fuse
F11	15A	BA03U-10	Tractor Markers
F12	30A	BA03B-10	Trailer Markers
F30	5A	Bus Bar	ECC Battery
F146	15A	Bus Bar	DRL Power
F44	15A	BA25A-12	ABS ECU Batt Power
F45	10A	IG03H-10	ABS ECU Ign Power
F15	20A	IG03K-10	Backup Lamp
F16	30A	IG03B-10	Option Ing Power
F47	20A	IG03H-10	Air Dryer
F20	5A	IG03J-12	ECC Lightbar
F21	15A	AC02A-10	Radio
F212	25A	Bus Bar	Sleeper
F23	20A	AC02B-10	Htd Mirror/lighter
F24	5A	Bus Bar	Wiper Switch
F25	20A	AC02B-10	Opt Accessory Fus
F27	30A	Bus Bar	Cab Heater
F18	10A	Bus Bar	RHS Low Beam
F19	10A	Bus Bar	LHS Low Beam
F29	15A	Bus Bar	RHS High Beam
F28	15A	Bus Bar	LHS High Beam

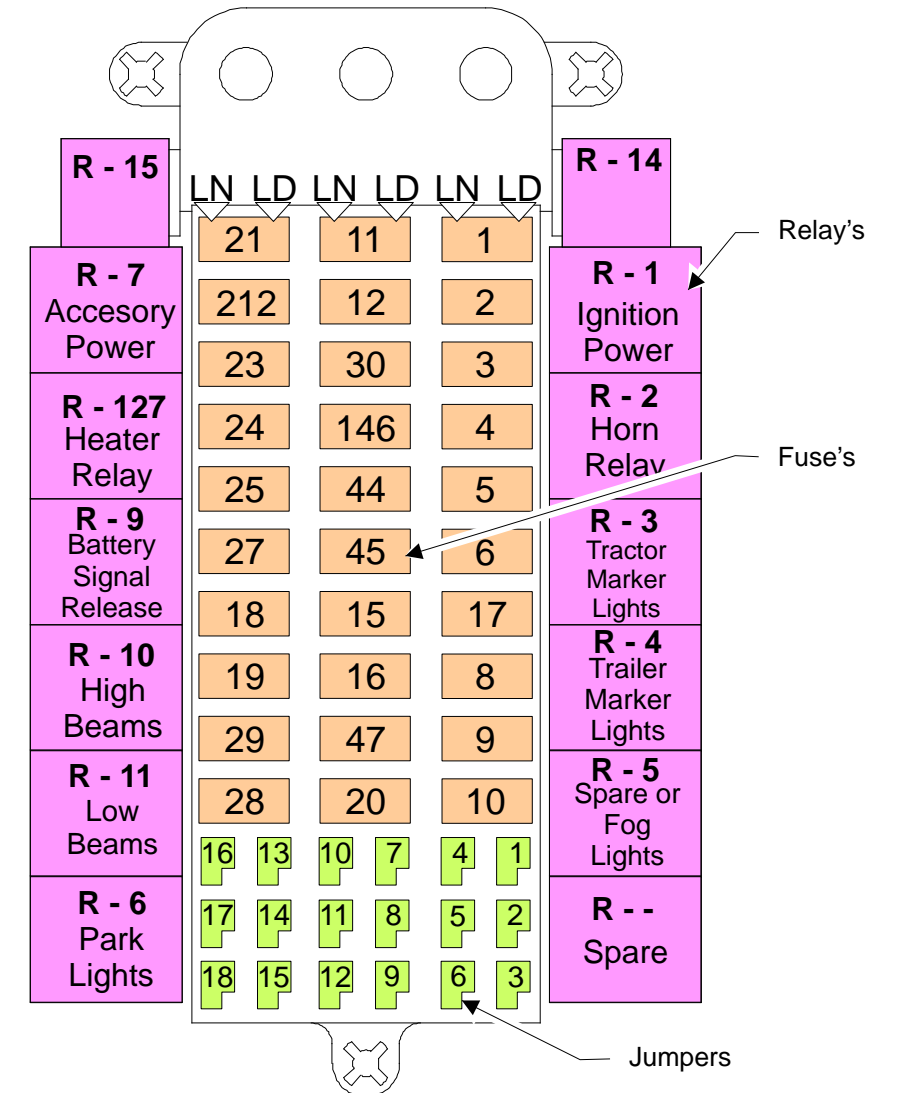

Main Fuse/Relay Panel

Optional Fuse/Relay Panel

Optional fuse panels are used to support additional switches and other custom options. The WST system is designed to support up to 20 Fuses and 11 relays. Additional fuse blocks and switches can be ordered for customer use, see the Switch page for more information.

Fuse block quantity will change based on the amount of extra switches ordered

Fuse max 20A

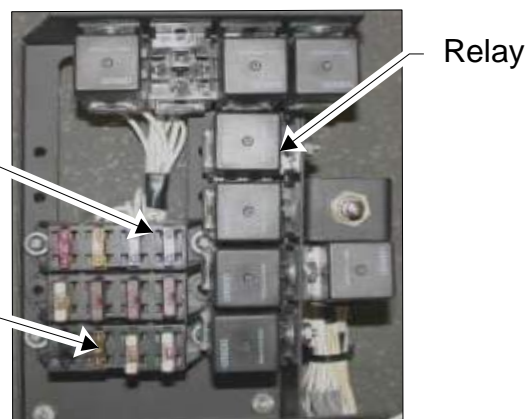

Optional Fuse Panel

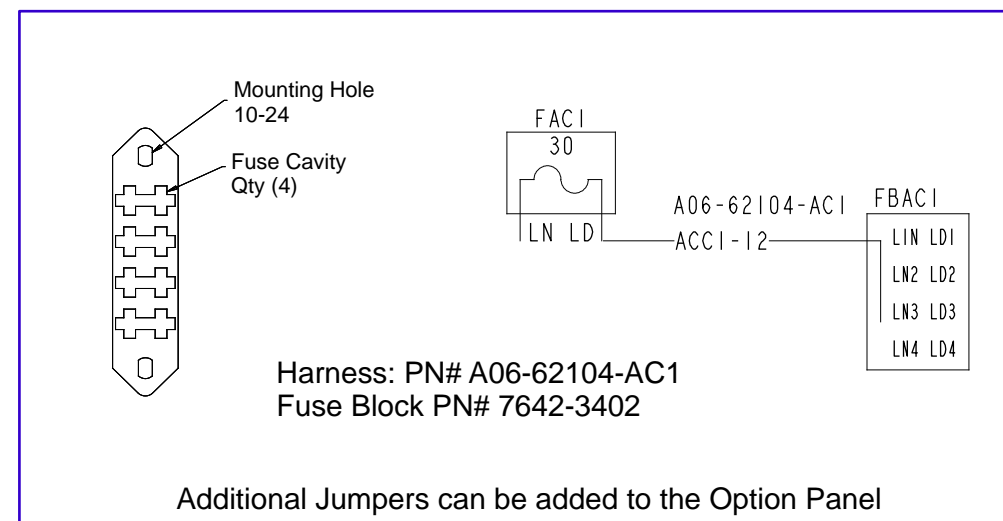



WESTERN STAR

4700 In Cab Body Builder Connections With PDM

353-060 Vehicle interface blunt cut wiring with fuse panel wire mounted between driver and passenger seats

In Cab Body Builder PDM

- Dedicated raceway to route wiring for body install
- Floor Tray accommodates (6) 1/2" bundles
- Raceway system provides access cover to route wires
- Cab access through access floor plate 4" pass-thru in cab floor
- In-cab body builder fuse and relay system isolates body controls from truck system for a simple and more reliable truck and Body integration operation

Body Builder PDM is Mandatory with the following high amperage switch options the PDM unit can be omitted in certain cases with these combinations where the body builder is supplying their own PDM (engineering review required)

- 329-1AX** (10) **10 amp** switches wired behind passenger seat
- 329-068** (4) **20 amp** switches wired behind passenger seat
- 329-072** (6) **20 amp** switches wired behind passenger seat
- 329-076** (10) **20 amp** switches wired behind passenger seat

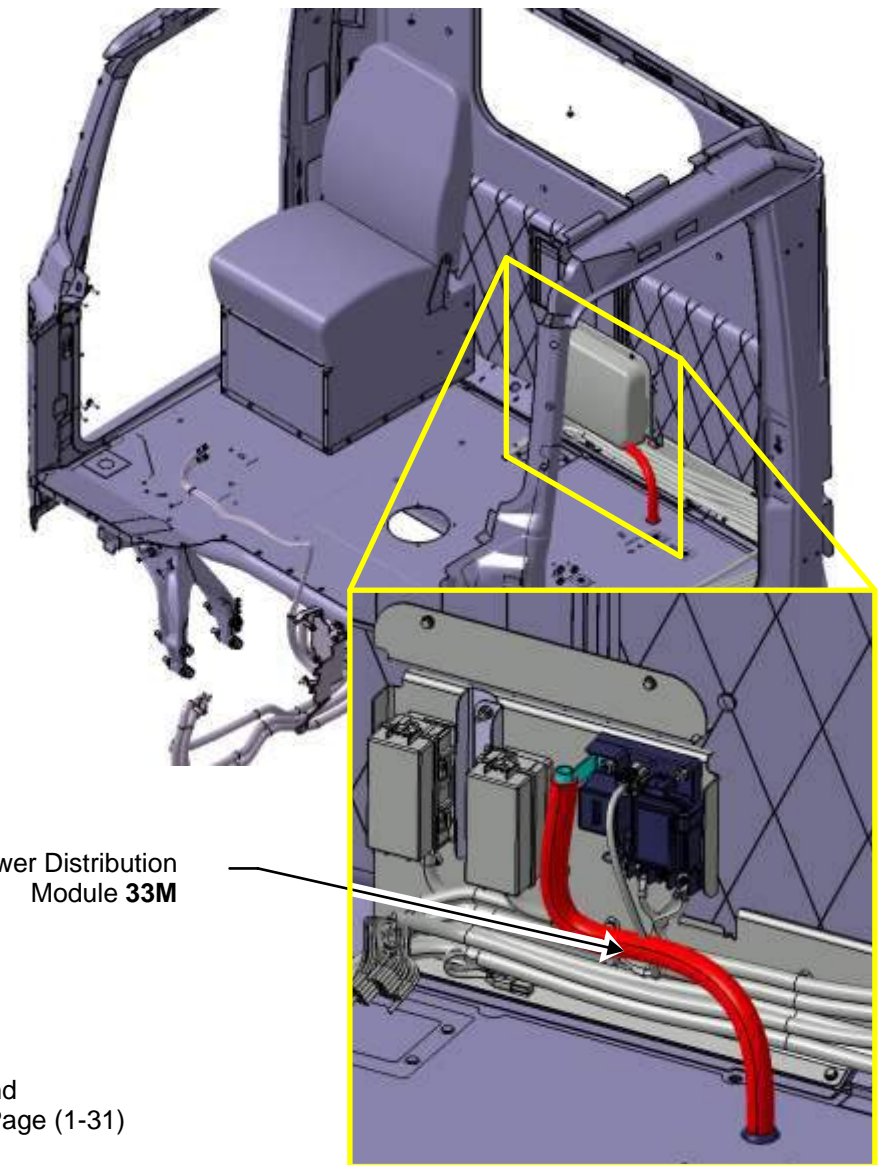

AUXILIARY PNDB
Module 33P

Body Lighting PDM
Module 353

Mounting Bracket
Module 33M

Cab Aux
Power Cable
Module 33M

Cab Floor Harness
Module 287

Power Distribution
Module 33M

Blunt cut switch connections
Pre wired to dash switches and
lighting PDM see schematic Page (1-31)
Module 329



4700 SF/SB In Cab Floor Track System and Cab Passthrough Connections

Included with 329-1AU, 329-1AV, 329-1AW, 329-1AX, 329-064
329-068, 329-072, 329-076 and 353-060 Options

****See section 1B page 1B-17 for installation tips and schematics****



In Floor Tray Cover

Easy access electrical tray makes adding cab harnesses easy in the field

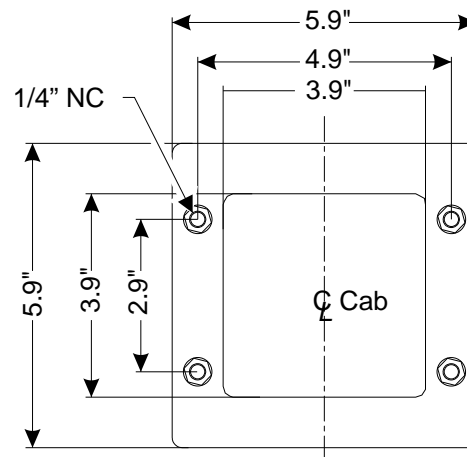

Easy Access Floor Plate



Pre cut floor mats

Cab Floor access

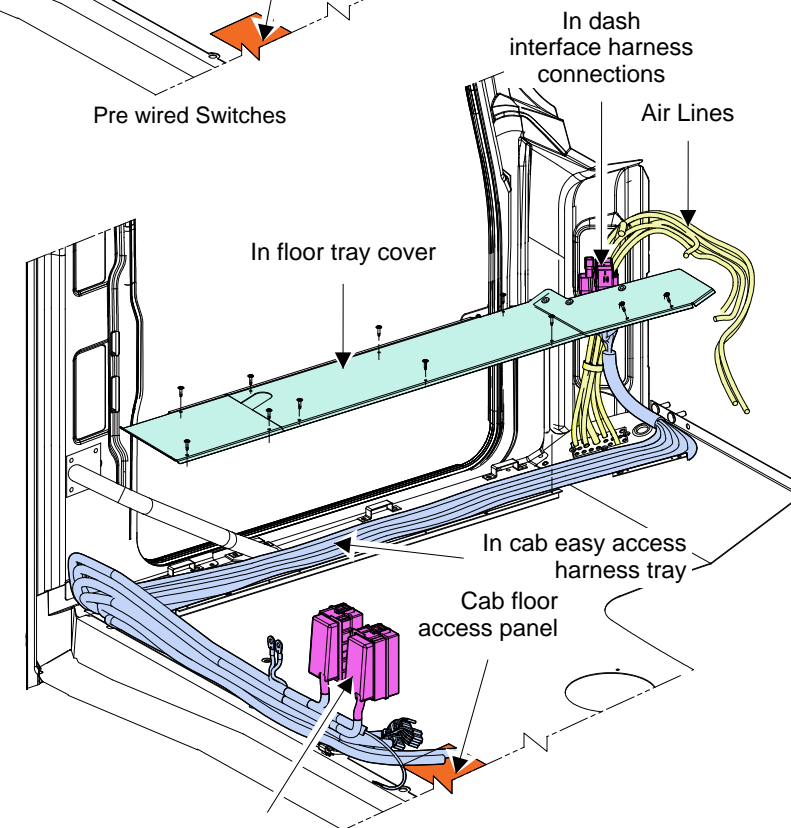
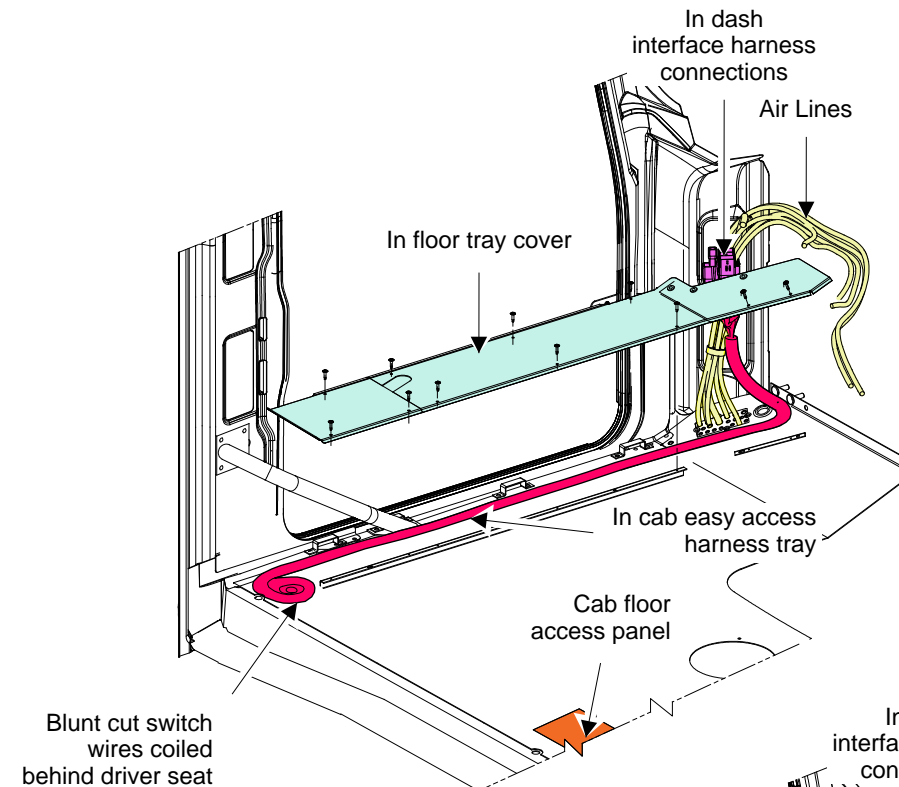

In Cab Vehicle interface Unit

PDM Unit 353-060



Additional Switch Package Options

4800/4900/6900 Switch and Wiring packages

Pre Labeled Additional Switch Options:

- WST offers many customized switch options to help the body builder add functionality and body controls.
- Western Star marine grade high current switches are designed for long term duty cycles under severe conditions.
- Listed to the right are some of the common switch options available that provide pre installed dash switches and wiring depending on the option selected.
- Switches are designed with a separate facing that attaches to the switch body.
- Custom switch facings can be selected and factory installed using the following switch label pages.
- Wiring schematics for these options are also located in this chapter see Index.

4700 10 Amp Switches	
329-1AU	TWO IGNITION CONTROLLED EXTRA SWITCHES WITH INDICATOR LIGHT, 10 AMPS, WIRED BETWEEN PASSENGER/DRIVER SEAT
329-1AV	FOUR IGNITION CONTROLLED EXTRA SWITCHES WITH INDICATOR LIGHT, 10 AMPS, WIRED BETWEEN PASSENGER/DRIVER SEAT
329-1AW	SIX IGNITION CONTROLLED EXTRA SWITCHES WITH INDICATOR LIGHT, 10 AMPS, WIRED BETWEEN PASSENGER/DRIVER SEAT
329-1AX	TEN IGNITION CONTROLLED EXTRA SWITCHES WITH INDICATOR LIGHT, 10 AMPS, WIRED BETWEEN PASSENGER/DRIVER SEAT

4700 20 Amp Switches	
329-064	(2) Two ignition controlled extra switches with indicator light, 20 amps, wired behind passenger seat
329-068	(4) Four ignition controlled extra switches with indicator light, 20 amps, wired behind passenger seat
329-072	(6) Six ignition controlled extra switches with indicator light, 20 amps, wired behind passenger seat
329-076	(10) Ten ignition controlled extra switches with indicator light, 20 amps, wired behind passenger seat

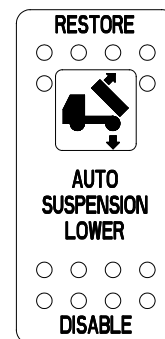

Complex Switch with Icon

Option	Description
329-001	1 EXTRA SWITCH IN DASH
329-002	2 EXTRA SWITCHES IN DASH
329-003	3 EXTRA SWITCHES IN DASH
329-004	4 EXTRA SWITCHES IN DASH
329-020	5 EXTRA SWITCHES IN DASH
329-018	6 EXTRA SWITCHES IN DASH
329-025	7 EXTRA SWITCHES IN DASH
329-022	8 EXTRA SWITCHES IN DASH
329-026	9 EXTRA SWITCHES IN DASH
329-021	10 EXTRA SWITCHES IN DASH
329-006	1 EXTRA SWITCH IN DASH WITH INDICATOR LAMP AND WIRE TO CHASSIS AT BACK OF CAB/SLEEPER
329-010	2 EXTRA SWITCHES IN DASH WITH INDICATOR LAMP AND WIRE TO CHASSIS AT BACK OF CAB/SLEEPER
329-017	3 EXTRA SWITCHES IN DASH WITH INDICATOR LAMP AND WIRE TO CHASSIS AT BACK OF CAB/SLEEPER
329-012	4 EXTRA SWITCHES IN DASH WITH INDICATOR LAMP AND WIRE TO CHASSIS AT BACK OF CAB/SLEEPER
329-056	4 EXTRA SWITCHES IN DASH WITH INDICATOR LAMP AND RELAYS WIRED TO CHASSIS AT BACK OF CAB/SLEEPER
329-050	5 EXTRA SWITCHES WITH INDICATOR LAMP AND WIRE TO CHASSIS AT BACK OF CAB/SLEEPER
329-051	6 EXTRA SWITCHES WITH INDICATOR LAMP AND WIRE TO CHASSIS AT BACK OF CAB/SLEEPER
329-080	7 EXTRA SWITCHES WITH INDICATOR LAMP AND WIRE TO CHASSIS AT BACK OF CAB/SLEEPER
329-078	8 EXTRA SWITCHES IN DASH WITH INDICATOR LAMP AND WIRE TO CHASSIS AT BACK OF CAB/SLEEPER
329-046	10 EXTRA SWITCHES WITH INDICATOR LAMP AND WIRE TO CHASSIS AT BACK OF CAB/SLEEPER
329-043	2 EXTRA SWITCHES IN DASH WITH INDICATOR LAMP AND WIRE TO CHASSIS EOF
329-034	4 EXTRA SWITCHES IN DASH, W/IND LAMP AND WIRE TO ENGINE FIREWALL
329-052	4 EXTRA SWITCHES IN DASH WITH INDICATOR LAMPS, WIRED TO END OF FRAME WITH SIX FEET EXTRA COILED WIRE
329-053	4 EXTRA SWITCHES IN DASH WITH MOMENTARY CONTACT
329-054	5 EXTRA SWITCHES WIRED TO 9 POLE JUNCTION BOX MOUNTED BEHIND PASSENGER SEAT (YRB)
329-058	3 20 AMP EXTRA SWITCHES IN DASH WITH INDICATOR LAMP AND RELAYS WIRED TO CHASSIS AT BACK OF CAB/SLEEPER
329-079	4 20 AMP FUSED EXTRA SWITCHES IN DASH WITH INDICATOR LAMP, WIRED TO FIREWALL, (1) SWITCH TO BE BATTERY POWERED
329-084	3 EXTRA SW IN DASH; 2 SUPPLIED W/BATT DIRECT POWER
329-084	6 IGN CTRLD ON/OFF ROCKER SWITCH IN DASH W/ IND LTS & WR RTD TO CH BOC/ S,LABEL OPT

Note:

New solutions can be created for multiple order units. If you do not see what you are looking for or need more information contact your WST Sales contact and we can work with you to create a custom solution.





Optional Switch Types All Models

Specific Switch Types:

Mod 329 optional switch packages can be customized with the following predefined switch bodies by adding a line note to the sales order.

Step 1

Select the 329-XXX option to drive the number of extra switches you require

Step 2

Have the dealer salesmen add the part numbers for the spare switch types from the choices on the this page that you would like pre installed.

The addition of the line note will drive a demand and the factory will install the corresponding switch bodies in lieu of standard switch normally installed in the truck.

Note:

Switches will come pre-wired as per the current optional switch data codes but will not be pre-wired to the locations defined by the switch label.

12V Switches									
WST PART NUMBER	CARLINGSWITCH PART NUMBER	TYPE	POS	FUNCTION	LED COLOUR		Type	VOLTS	
					1	2			
7530-3476	VCH999-167816001			SOCKET					
7805-3416	VMP390-09002-001			CAVITY PLUG					
7805-3404	V4D17NHB-00000	SPDT	2	ON NONE ON	AMBER	GREEN	A	12V	
7805-3405	V4D17NTB-00000	SPDT	2	ON NONE ON	AMBER	RED	A	12V	
7805-3406	V4D11NOB-00000	SPDT	2	ON NONE ON	AMBER	-	B	12V	
7805-3407	VDD17NHB-00000	DPDT	2	ON NONE ON	AMBER	GREEN	C	12V	
7805-3408	VDD17NTB-00000	DPDT	2	ON NONE ON	AMBER	RED	C	12V	
7805-3409	VDD11NOB-00000	DPDT	2	ON NONE ON	AMBER	-	D	12V	
7805-3410	V8D11NOB-00000	SPDT	3	(ON) OFF (ON)	AMBER	-	E	12V	
7805-3411	VGDJXNHB-00000-000XWT1	DPDT	3	OFF ON ON	AMBER	GREEN	F	12V	
7805-3412	VXDJ1NOB-00000-XWS1	DPDT	3	OFF ON ON	AMBER	-	G	12V	
7805-3413	VXD11NOB-00000-XWZ1	SPDT	2	(ON) NONE ON	AMBER	-	H	12V	
7805-3417	VLD11NOB-00000	DPDT	3	(ON) OFF (ON)	AMBER	-	J	12V	
7805-3420	V6D11NOB-00000	SPDT	3	ON OFF ON	AMBER	-	K	12V	
7805-3422	VJD17NHB-00000	DPDT	3	ON OFF ON	AMBER	GREEN	L	12V	
7805-3423	VGD1XNHB-00000-000XWT1	DPDT	3	OFF ON ON	AMBER	GREEN	M	12V	
7805-3424	VXD11NOB-00000-XWT1	DPDT	2	(ON) NONE ON	AMBER	-	N	12V	

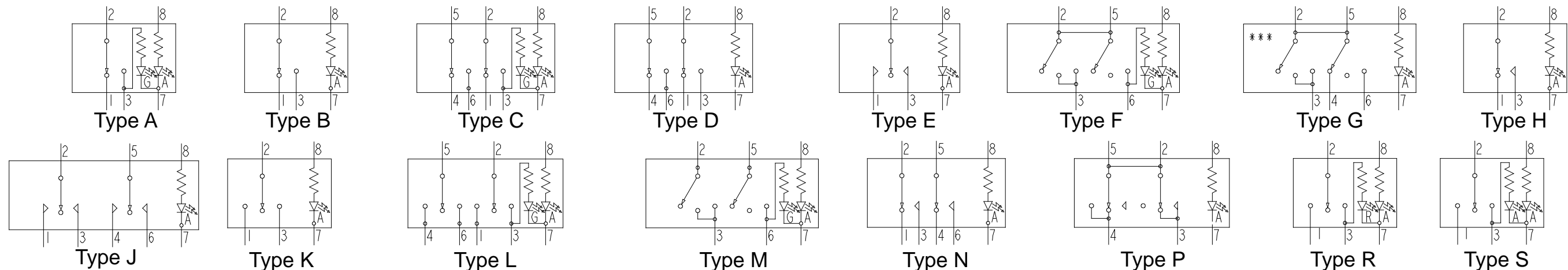
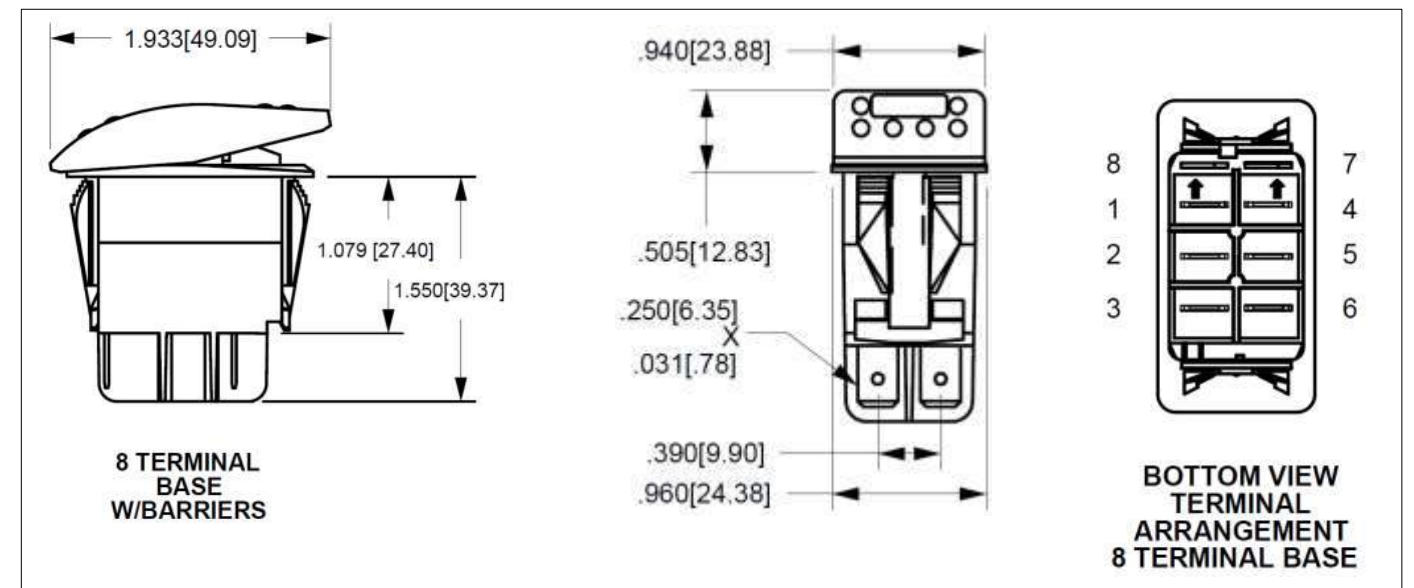



Optional Switch Actuators Component Application Switches All Models

Specific Switch Labels:

Mod 329 optional switch packages can be customized with the following predefined switch labels by adding a line note to the sales order.

Step 1

Select the 329-XXX option to drive the number of extra switches you require

Step 2

Have the dealer salesmen add the part numbers for the spare switches from the choices on the this page that you would like pre installed.

The addition of the line note will drive a demand and the factory will install the corresponding switch facing in lieu of standard OPT switches in the truck.

Note:

Switches will come pre-wired as per the current optional switch data codes but will not be pre-wired to the locations defined by the switch label.

Text Area with light

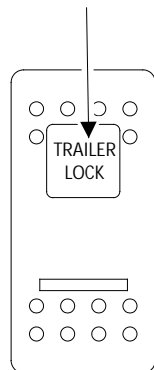



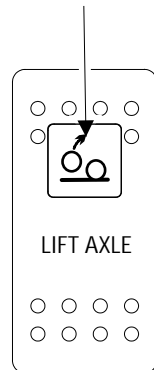

Simple Text Switch

Graphics Area

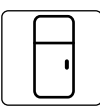

Graphic Icon Switch

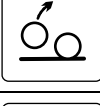
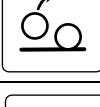
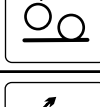
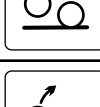
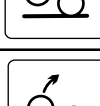
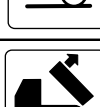
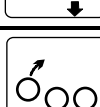
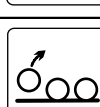
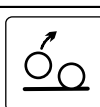
Part Number	Label Description	Indicat or Light	Switch Type	Graphics yes/No	type
7830-3454	MOBILE PHONE	Yes	2	N	Cab/sleeper
06-77236-000	BACKUP CAMERA	Yes	2	N	Cab/sleeper
7830-7030	FAN HIGH/OFF/LOW	No	3	N	Cab/sleeper
7830-3555	REAR CAM	Yes	2	N	Cab/sleeper
7830-3449	SPARE	Yes	2	N	Spare
7830-3563	SPARE #1	Yes	2	N	Spare
7830-3564	SPARE#2	Yes	2	N	Spare
7830-3516	#1	Yes	2	N	Spare
7830-3517	#2	Yes	2	N	Spare
7830-3529	ACC 1	Yes	2	N	Spare
7830-3530	ACC 2	Yes	2	N	Spare
7830-3443	AUX	Yes	2	N	Spare
7830-3507	AUX #2	Yes	2	N	Spare
7830-3421	BLANK	Yes	2	N	Spare
7830-3427	BLANK	No	2	N	Spare
7830-3525	MISC	Yes		N	Spare
7830-3548	AXLE1	Yes	2	N	Suspension
7830-3549	AXLE2	Yes	2	N	Suspension
06-69691-000	AXLE3	Yes	2	N	Suspension
7830-7055	FRONT AXLE	Yes	2	N	Suspension
7830-3540	TRAILER	Yes	2	N	Trailer
7830-3490	TRAILER AUX	Yes	2	N	Trailer
7830-3448	TRAILER BACKUP	Yes	2	N	Trailer
7830-7032	TRAILER DOOR	Yes	2	N	Trailer
7830-3457	TRAILER DUMP	Yes	2	N	Trailer
7830-3444	TRAILER GATE	Yes	2	N	Trailer
7830-7036	TRAILER LOCK	Yes	2	N	Trailer
7830-3484	TRAILER PIN	Yes	2	N	Trailer
06-74626-000	TRAILER POWER	Yes	2	N	Trailer
06-71939-000	TRAILER POWER FRONT	Yes	2	N	Trailer
06-71940-000	TRAILER POWER REAR	Yes	2	N	Trailer
7830-7034	TRAILER SUSP	Yes	2	N	Trailer
7830-7056	TRAILER AXLE 1	Yes	2	N	Trailer
7830-7057	TRAILER AXLE 2	Yes	2	N	Trailer
7830-7059	HOIST TRAILER UP/DOWN	No	2	N	Trailer

Part Number	Label Description	Indicat or Light	Switch Type	Graphics yes/No	type
7830-3518	FRIDGE	Yes	2		Cab/sleeper
7830-3461	QUALCOM	Yes	2		Cab/sleeper
7830-3524	LIFT AXLE	Yes	2		Suspension
7830-3534	LIFT AXLE A	Yes	2		Suspension
7830-3535	LIFT AXLE B	Yes	2		Suspension
7830-7027	PUP LIFT AXLE	No			Suspension
7830-7009	PUSHER AXLE	Yes	2		Suspension
7830-7010	TAG AXLE	Yes	2		Suspension
7830-3597	AUTO SUSP LOWER REST/DISBL	No	3		Suspension
7830-3430	TRAILER 3RD AXLE LIFT	Yes	2		Trailer
7830-3481	TRAILER 4TH AXLE LIFT	Yes	2		Trailer
7830-7049	TRAILER LIFT AXLE	Yes	2		Trailer



Optional Switch Facings

Lighting Application Switches All Models

Part Number	Label Description	Indicator Light	Switch Type	Graphics Yes/No	Type
7830-3552	REAR BEACON	Yes	2	N	Light
7830-3551	FRONT BEACON	Yes	2	N	Light
7830-3522	BACKUP LIGHT #1	Yes	2	N	Light
7830-3523	BACKUP LIGHT #2	Yes	2	N	Light
06-69939-000	BLADE LIGHT	Yes	2	N	Light
7830-3558	BLUE FLASHER	Yes	2	N	Light
7830-3466	BODY LIGHTS	Yes	2	N	Light
7830-3476	BOOM LIGHTS	Yes	2	N	Light
06-69940-000	BOX LIGHT	Yes	2	N	Light
7830-3546	BUD LIGHTS	Yes	2	N	Light
06-74094-000	BUMPER LIGHTS	Yes	2	N	Light
7830-7048	CL LIGHTS	Yes	2	N	Light
7830-3562	DECK LIGHTS	Yes	2	N	Light
7830-3520	DOCK LIGHTS	Yes	2	N	Light
7830-3589	EXIT LIGHTS	Yes	2	N	Light
7830-3527	EXTRA LIGHTS	Yes	2	N	Light
7830-7042	FLOOD LIGHT	Yes	2	N	Light
7830-7047	ID LIGHTS	Yes	2	N	Light
7830-3532	LEFT LIGHT	Yes	2	N	Light
7830-7012	LOADER LIGHTS	Yes	2	N	Light
7830-3550	NEON	Yes	2	N	Light
7830-3456	O/O LIGHTS	Yes	2	N	Light
7830-3542	OD LIGHT	Yes	2	N	Light
7830-7054	OFF ROAD LIGHTS	Yes	2	N	Light
7830-3526	PICKER LIGHTS	Yes	2	N	Light
7830-3559	PLOW LIGHTS	Yes	2	N	Light
7830-3446	RACK LIGHTS	Yes	2	N	Light
7830-3469	REAR FLOOD LTS	Yes	2	N	Light
7830-3533	RIGHT LIGHT	Yes	2	N	Light
7830-3553	SANDER LIGHT	Yes	2	N	Light
7830-7016	SANDER LIGHT FRONT	Yes	2	N	Light
7830-7017	SANDER LIGHT REAR	Yes	2	N	Light
7830-3554	SCRAPER LIGHT	Yes	2	N	Light
7830-3560	SPINNER LIGHT	Yes	2	N	Light
7830-3437	TANK LIGHTS	Yes	2	N	Light
7830-7040	TIRE LIGHTS	Yes	2	N	Light
7830-7033	TRAILER LIGHT	Yes	2	N	Light
7830-3556	WINCH LIGHTS	Yes	2	N	Light
7830-7050	TOOL LIGHTS	Yes	2	N	Light
7830-3545	WING LIGHTS	Yes	2	N	Light
7830-3561	YELLOW FLASHER	Yes	2	N	Light
7830-3539	CRTSY	Yes	2	N	Light
7830-3543	DAYTIME	Yes	2	N	Light
7830-3451	FENDER MARKER	Yes	2	N	Light
7830-3504	FLASH	Yes	2	N	Light
7830-3478	FLOOD	Yes	2	N	Light
7830-7045	FRONT	Yes	2	N	Light
7830-3471	FRONT TARP	Yes	2	N	Light
7830-3479	MARKER	Yes	2	N	Light
7830-3538	MOOSE	Yes	2	N	Light
7830-3472	REAR TARP	Yes	2	N	Light
7830-3510	TOOL BOX	Yes	2	N	Light
7830-3541	TRUCK	Yes	2	N	Light
06-73290-000	UTILITY	Yes	2	N	Light
7830-3460	WIDE LOAD	Yes	2	N	Light

Part Number	Label Description	Indicator Light	Switch Type	Graphics Yes/No	Type
7830-7038	MIRROR BACKUP LIGHTS	Yes	2		Light
7830-3422	BEACON	Yes	2		Light
7830-3509	BEACON #2	Yes	2		Light
7830-3406	BACKUP LIGHTS	Yes	2		Light
7830-3584	BACKUP LIGHTS STEP	Yes	2		Light
7830-3595	ALTERN FLASHERS	Yes	2		Light
7830-3492	BULL LIGHTS	Yes	2		Light
7830-3594	CARGO BOX LIGHT	Yes	2		Light
7830-3547	CHAINUP LIGHTS	Yes	2		Light
7830-3402	CL / ID LIGHTS	Yes	2		Light
7830-3404	DRIVING LIGHTS	Yes	2		Light
7830-3528	EXT. LIGHTS	Yes	2		Light
7830-3405	FOG LIGHTS	Yes	2		Light
7830-7043	FRONT STROBE	Yes	2		Light
7830-3497	FRONT WORK LAMPS	Yes	2		Light
7830-3496	HEADLAMP REMOTE NORMAL	Yes	2		Light
7830-3503	HOOK UP LIGHTS	Yes	2		Light
7830-3583	HOPPER LIGHT	Yes	2		Light

Part Number	Label Description	Indicator Light	Switch Type	Graphics Yes/No	Type
7830-3439	LOAD LIGHT	Yes	2		Light
7830-3498	REAR WORK LAMPS	Yes	2		Light
7830-3431	SPOT LIGHT	Yes	2		Light
7830-7022	STROBE	No	2		Light
7830-3567	TRAILER LOAD LIGHT	Yes	2		Light
7830-3566	TRUCK LOAD LIGHT	Yes	2		Light
7830-3596	UNDERBODY LIGHT	Yes	2		Light
7830-7039	UTILITY LIGHTS	Yes	2		Light
7830-7044	TOP STROBE	Yes	2		Light
7830-3582	WING MARKER LIGHT	Yes	2		Light
7830-3438	WORK LIGHTS	Yes	2		Light
7830-3512	FRONT FLOOD	Yes	2		Light
7830-3414	HI/LOW	No	2		Light
7830-3413	HI/MED/LOW	No	2		Light
7830-3513	REAR FLOOD	Yes	2		Light
7830-3515	REAR STROBE	Yes	2		Light
7830-3565	TRUCK BACK-UP	Yes	2		Light
7830-3511	SIDE FLOOD	Yes	2		Light

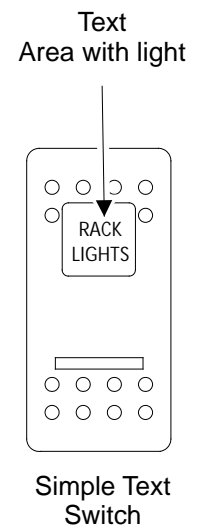
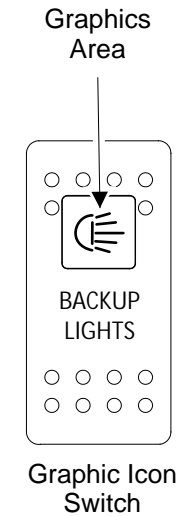



Optional Switch Facings Body Application Switches All Models

Graphics Area

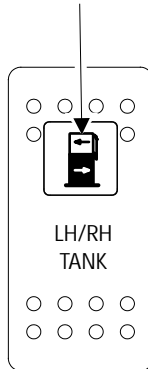

Graphic Icon Switch

Text Area with light

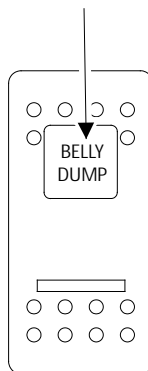

Simple Text Switch

Part Number	Label Description	Indicator Light	Switch Type	Graphics yes/No	type
7830-7003	BED	Yes	2	N	Body
7830-3455	ALARM	Yes	2	N	Body
7830-3477	BACKUP ALARM	Yes	2	N	Body
7830-7051	BOOM UP/DOWN	No	2	N	Body
06-77769-000	AIR GATE	Yes	2	N	Body
06-77770-000	AIR TARP	Yes	2	N	Body
7830-3598	AUX RANGE HIGH/LOW	Yes	2	N	Body
7830-3486	BELLY DUMP	Yes	2	N	Body
7830-3465	BLOWER	Yes	2	N	Body
7830-3569	BOOM	Yes	2	N	Body
7830-7052	BOOM IN/OUT	No	2	N	Body
7830-7014	CHAIN	Yes	2	N	Body
7830-7015	CHAIN 2-SPEED	Yes	2	N	Body
7830-3577	CHUTE RAISE/LOWER	No	2	N	Body
7830-7006	CHUTE UNLOCK/LOCK/REMOTE	Yes	3	N	Body
7830-3531	CONTROL	Yes	2	N	Body
7830-3489	CRANE	Yes	2	N	Body
7830-3508	DIVERTER	Yes	2	N	Body
7830-3467	DIVIDER BOX	Yes	2	N	Body
7830-3570	DOLLY	Yes	2	N	Body
7830-7035	DOLLY LOCK	Yes	2	N	Body
7830-3475	DUMP	Yes	2	N	Body
06-73288-000	DUMP FRONT	Yes	2	N	Body
06-73289-000	DUMP REAR	Yes	2	N	Body
7830-3572	FRONT/REAR THROTTLE CONTRL	Yes	2	N	Body
7830-3590	GATE ONE	Yes	2	N	Body
7830-3591	GATE TWO	Yes	2	N	Body
7830-3470	GENERATOR	Yes	2	N	Body
7830-7041	GROUND SPEED	Yes	2	N	Body
7830-3494	SANDER FRONT	Yes	2	N	Body
7830-3495	SANDER REAR	Yes	2	N	Body

Part Number	Label Description	Indicator Light	Switch Type	Graphics yes/No	type
7830-7058	HOIST TRUCK UP/DOWN	No	2	N	Body
7830-3579	HOPPER UP/DOWN/REMOTE	Yes	3	N	Body
7830-3499	HYD COOLER	Yes	2	N	Body
7830-7028	HYD FAN	No	2	N	Body
7830-3468	HYD. PUMP	Yes	2	N	Body
7830-3441	LOADER	Yes	2	N	Body
7830-3502	MASTER	Yes	2	N	Body
7830-3574	MIXER MIX/DISCHARGE	No	2	N	Body
7830-3576	MIXER STOP/RESUME/REMOTE	No	3	N	Body
7830-3442	PIN LOCK	Yes	2	N	Body
7830-3544	PLOW	Yes	2	N	Body
06-73287-000	POWER	Yes	2	N	Body
7830-3580	PTO	Yes	2	N	Body
06-77891-000	PUMP	Yes	2	N	Body
7830-3447	PUP PIN	Yes	2	N	Body
7830-7025	PUP T/GATE	No	2	N	Body
7830-7023	PUP TARP	No	2	N	Body
7830-3440	RACK	Yes	2	N	Body
7830-3571	REAR	Yes	2	N	Body
7830-3500	REMOTE	Yes	2	N	Body
7830-7013	SANDER DOOR	Yes	2	N	Body
7830-3557	SENSOR	Yes	2	N	Body
7830-3483	SHUTDOWN	Yes	2	N	Body
7830-3474	TAIL GATE	Yes	2	N	Body
7830-7019	TARP	No	2	N	Body
7830-7029	TARP	Yes	2	N	Body
7830-7053	TILT UP/DOWN	No	2	N	Body
7830-3453	TIRE CHAINS	Yes	2	N	Body
7830-7026	TRUCK T/GATE	No	2	N	Body
7830-7024	TRUCK TARP	No	2	N	Body
7830-7060	TURNTBL LOCK IN/OUT	Yes	2	N	Body

Part Number	Label Description	Indicator Light	Switch Type	Graphics yes/No	type
7830-3418	LH/RH TANK	No	2		Body
7830-3436	POWER TAKE OFF	No	2		Body
06-74457-000	SHUTDOWN OVERRIDE	No	2		Body
7830-7007	TRANSFER CASE LOCK	Yes	2		Body
7830-3485	VIBRATOR	Yes	2		Body



WESTERN STAR

WST Air System All Models

WST Air System

- The Western Star air system is designed for easy access and adaptability after delivery.
- In line air connections to all chassis components are located conveniently under driver's door cab skirt.
- To aid Body Builder connection access, the floor pass through has extra ports in various sizes. This pass through is located under the dead pedal as shown.
- Primary supply air is also available by tapping into the supply manifold located under the dash or by using a jumper as show below.

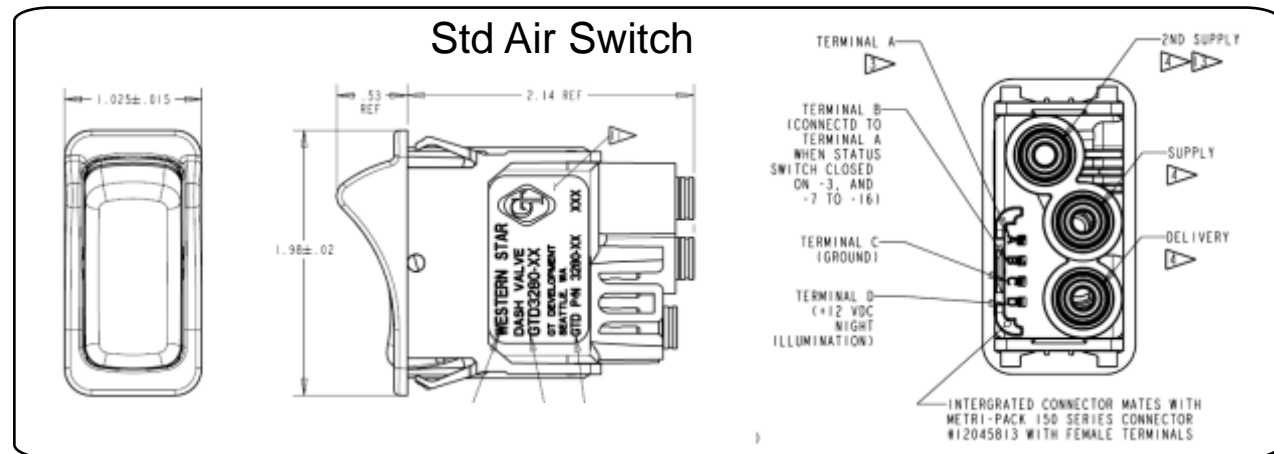

Airlines and cab pass through are located under the drivers dead pedal

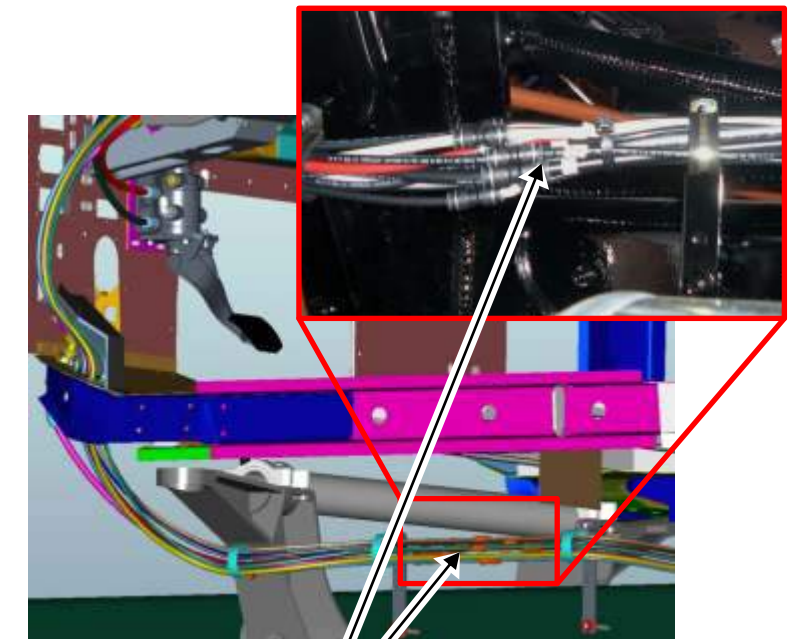

In line connections under cab allow for greater flexibility when connecting or changing air control systems

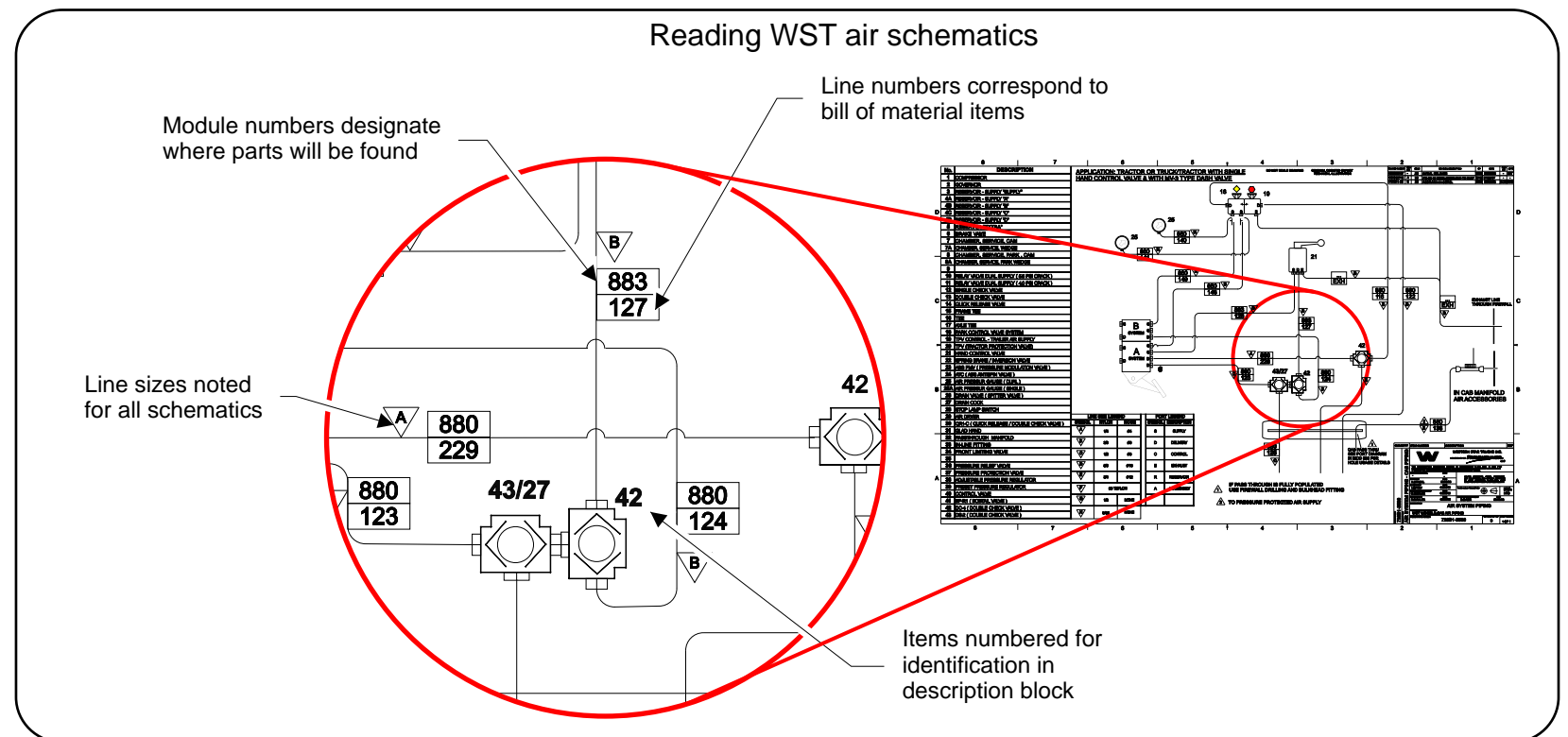
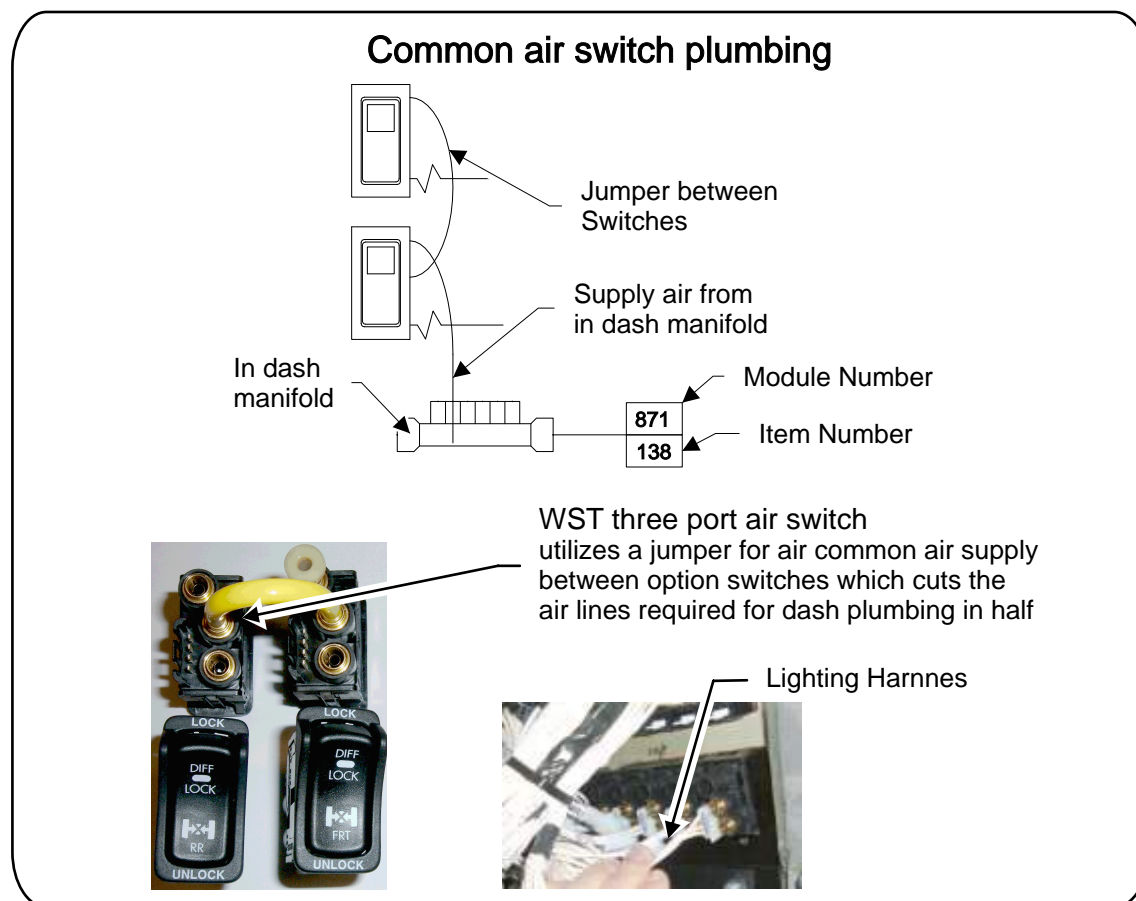



4800/4900/6900 Airline Numbering Circuits 1 to 100

Airline Number System

The WST air system assigns separate line numbers for each connection line in the air system design. Most air lines are black but some air lines have been assigned colors and sizes for some common routing and as such the colored air lines will have no number labels. Where a black line is used number labels are used to identify which lines go to different places on the chassis these numbers correspond to the circuit numbers in the schematic drawings. All black and wire braid lines connecting to the cab will be labeled with a line number on both the cab sides and the chassis line in an area where no paint or over spray will cover them up.

Color designated Lines will not have line numbers see color/size column for more information

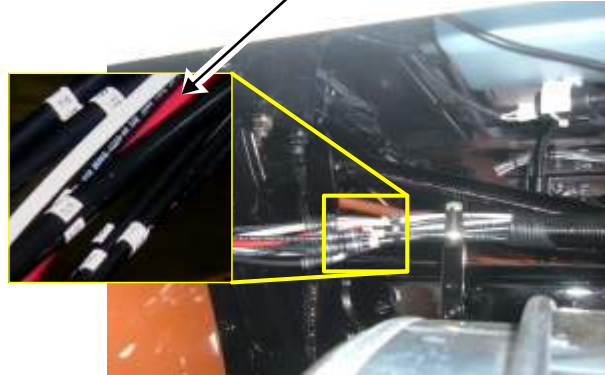

Under cab line connections

Airline numbers on black lines

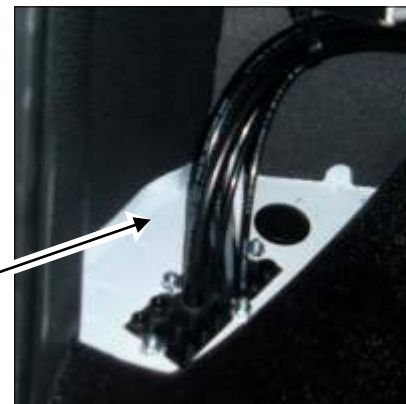

Additional air line ports are provided for easy addition of body builder controls

Cab pass through manifold located behind driver side dead pedal

Airline Color/Size	Airline Number	Airline Number Description
	1	(BC Air only) - air compressor to wet tank
	2	(BC Air only) - wet tank supply to dry tanks
	3	Wet tank drain to moisture ejector
	4	Governor signal to moisture ejector
	5	(BC Air only) - dry tank 'C' to governor
	6	Dry air supply to relay valve
	7	(BC Air only) - cab manifold supply - wet
	8	Dry tank supply to emergency tank
	9	Transmission supply
	10	Emergency tank supply to park valve
	11	(BC Air only) - control forward rear axle relay valve
	12	(BC Air only) - brake valve supply to front chamber
	13	(BC Air only) - front axle quick release valve supply to frame
	14	Supply - deep reduction control
	15	Trailer service
	16	Trailer emergency
	17	(BC Air only) - forward rear axle tee supply to service chamber
	18	(BC Air only) - relay valve supply to rear axle quick release valve
	19	(BC Air only) - rear-rear axle tee supply to service chamber
	20	(BC Air only) - cab manifold to control valve - dry
	21	(BC Air only) - hand control valve to trailer service
	22	(BC Air only) - tractor protection control supply to trailer emergency
	23	(BC Air only) - park control supply to frame tee
	24	(BC Air only) - quick release valve to park brake chamber
	25	Differential lock-out control supply to axle
White	25A	Differential lock-out control supply to axle

Airline Color/Size	Airline Number	Airline Number Description
	26	Deep reduction control supply to transmission
	27	Front brake limiting control to limiting valve
	28	Supply to fifth wheel lock
	29	Supply to air shift 2-speed axle
	30	Supply to air seat
	31	Supply to windshield wiper
	32	Supply to air horn
	33	Supply to reservoir pressure gauge
	34	Supply to wig wag
	35	Signal to stop lamp switch
	36	(BC Air only) - rear axle wedge chamber to wedge chamber
	37	Supply to front wheel limiting control
	38	Not yet assigned
	39	(BC Air only) - park brake drop lines
	40	'C' supply to pusher / tag relay valve
	41	'B' delivery to pusher / tag relay control
	42	Not yet assigned
	43	Not yet assigned
	44	Not yet assigned
	45	Not yet assigned
	46	Not yet assigned
	47	(BC Air only) - low pressure governor supply
	48	(BC Air only) - emergency dump valve to tractor protection valve
	49	(BC Air only) - signal to trailer emergency pressure gauge
	50	(BC Air only) - signal to trailer service gauge

Airline Color/Size	Airline Number	Airline Number Description
	51	(BC Air only) - rear brake application gauge supply
	52	(BC Air only) - dump valve to low pressure governor
	53	(BC Air only) - relay valve to axle tee service brake
	54	(BC Air only) - supply - dry air tank 'C' to forward rear axle relay
	55	(BC Air only) - supply - dry air tank 'B' to rear-rear axle relay valve
	56	(BC Air only) - control front brake relay valve
	57	(BC Air only) - supply front brake relay valve
	58	(BC Air only) - front brake relay valve to limit quick release valve
	59	Differential lock-out supply - wet air
	60	(BC Air only) - dry tank 'C' supply to double check valve
	61	(BC Air only) - park brake control 'D' to pressure holding valve
	62	(BC Air only) - park brake control 'D' to tractor park brake control
	63	(BC Air only) - dry tank 'B' supply to brake valve
	64	(BC Air only) - control rear-rear axle relay
	65	(BC Air only) - front axle drop lines to brake chambers
	66	(BC Air only) - supply to reservoir gauge & wig wag
	67	(BC Air only) - supply to front brake application gauge
	68	(BC Air only) - pressure holding valve to tractor protection valve 'S'
	69	Not yet assigned
	70	Not yet assigned
	71	Not yet assigned
	72	Not yet assigned
	73	Not yet assigned
	74	Not yet assigned
	75	Not yet assigned

Airline Color/Size	Airline Number	Airline Number Description
	76	Not yet assigned
	77	Not yet assigned
	78	Not yet assigned
	79	Not yet assigned
	80	Not yet assigned
	81	Not yet assigned
	82	Not yet assigned
	83	Not yet assigned
	84	Not yet assigned
	85	Not yet assigned
	86	Not yet assigned
	87	Not yet assigned
	88	Not yet assigned
	89	Not yet assigned
	90	Not yet assigned
	91	Not yet assigned
	92	Not yet assigned
	93	Not yet assigned
	94	Not yet assigned
	95	Not yet assigned
	96	Not yet assigned
	97	Not yet assigned
	98	Not yet assigned
	99	Not yet assigned
	100	Compressor discharge



4800/4900/6900 Airline Numbering Circuits 101 to 256

Airline Color/size	Airline Number	Airline Number Description
Green/#10	101	Supply to service 'A'
Red/#10	102	Supply to service 'B'
Green/#10	103	Service 'A' to brake valve supply
Red/#10	104	Service 'B' to brake valve supply
	105	Brake valve 'A' control to rear relay valve
Red/#8	106	Brake valve 'B' control to front relay valve
	107	Service 'A' to forward rear relay valve
	108	Service 'A' to rear-rear relay valve
	109	Service 'B' to front relay valve
	110	Rear-rear relay valve to service brake chambers
Red/#8	111	Front relay valve to service brake chambers
	112	Wet supply reservoir to governor
	113	Brake valve 'B' supply to double check valve
	114	Double check valve park brake control valve
	115	Park brake control valve to control valve - tractor trailer to tractor
	116	Trailer park brake control valve to quick release valve
	117	Quick release valve to frame tee
	118	Drop line frame tee to axle tee
	119	Drop line inversion valve to axle tee
	120	Quick release valve / double check valve or axle tee to spring brake chambers
	121	Park brake control valve to tractor protection control valve
Orange/#6	122	Tractor protection control valve to tractor protection valve
	123	Brake valve 'A' to double check valve
	124	Brake valve 'B' to double check valve
	125	Double check valve to tractor protection valve
	126	Brake valve 'A' to hand control valve
	127	Hand control valve to double check valve
	128	Hand control valve exhaust
	129	Front axle ratio valve to inversion valve
	130	Service 'A' to inversion valve
	131	Wedge brake chamber to wedge brake chamber
	132	Tee to anti-skid power switch
	133	Tee to double check valve 'A' system
Green/#8	134	'B' system to double check valve
	135	Tee to normally closed switch ("Kelsey Hayes" only)
	136	Brake valve 'B' to forward rear relay valve
	137	Rear axle relay valve to frame tee
Yellow/#8	138	Manifold supply - accessories
	139	Park brake control to tractor protection control valve port
	140	'B' supply to air gauge
	141	'A' supply to air gauge
	142	Quick release / double check valve to rear-rear relay valve
	143	Boost tank to tractor protection valve
	144	Park brake valve relay supply
	145	Forward rear relay valve to front brake valve
	146	Brake valve 'A' to forward rear relay valve
	147	Brake valve 'B' to rear-rear relay valve
	148	Brake valve 'A' to park brake control valve
	149	Brake valve 'B' to park brake control valve
	150	Bobtail ratio valve control

Airline Number	Airline Number	Airline Number Description
	151	Transmission - stationary / mobile control valve feed (s)
	152	Transmission - stationary / mobile control valve feed (m)
	153	Transmission - neutral cylinder feed
	154	Transmission - stationary / mobile control valve (s) delivery to splitter position sensing
	155	Transmission - stationary / mobile control valve (s) delivery to sequence protection valve
	156	Transmission - neutral cylinder to sequence protection valve
	157	Transmission retarder - skinner solenoid valve to retarder
	158	Transmission retarder - pressure switch to skinner valve
	159	Transmission retarder - skinner valve to foot valve
	160	Transmission retarder - control valve to supply
	161	Auxiliary transmission - control valve port 2 to shift cylinder
	162	Auxiliary transmission - control valve port 4 to shift cylinder
	163	Rear-rear pressure modulator valve to service chambers - ABS
	164	Rear relay valve to rear-rear pressure modulator /double check valve - ABS
	165	Anti-slip valve supply
	166	Anti-slip valve delivery to rear-rear pressure modulator valve double check valve - ABS
	167	Rear-rear pressure modulator valve delivery to un-sensored axle relay valve control - ABS
	168	Front pressure modulator valve to front service chambers
	169	Front quick release valve to front pressure modulator valve
	170	Brakesaver - 'A' supply to brakesaver pressure regulator valve inlet
	171	Brakesaver - regulating valve to hand control valve inlet
	172	Brakesaver - hand control valve delivery to double check valve
	173	Brakesaver - hand control valve exhaust
	176	Brakesaver - double check valve to brakesaver application gauge
	177	ATC/ASR relay valve delivery to un-sensored relay valve control - slaved
	178	Rear rear relay valve delivery to ASR relay valve control - ASR/ATC
	179	Tee 122 to BP-R1 bobtail valve
	180	Not yet assigned
	181	Not yet assigned
	182	Not yet assigned
	183	Not yet assigned
	184	Not yet assigned
	185	Not yet assigned
	186	Transfer case - supply from fail-safe side of pressure protection valve
	187	Transfer case - 2 speed shift dual shuttle valve to cylinder - A, B, C, D
	188	Transfer case - front axle disengage
	189	Transfer case - front axle engage
	190	Bendix cruise control - supply tank to pressure protection valve
	191	Bendix cruise control - pressure reducing valve to solenoid valve
	192	Bendix cruise control - solenoid valve to inversion valve
	193	Bendix cruise control - brake valve 'A' delivery to inversion valve
	194	Bendix cruise control - inversion valve to air cylinder
	195	Transfer case control - control valve to transfer case
	196	Transfer case control - 2 speed shift - low
	197	Transfer case control - 2 speed shift - high
	198	Transfer case control - neutral

Airline Color/Size	Airline Number	Airline Number Description
	201	Axle lift control line
	202	'B' or 'C' supply to lift control
	203	Pusher load bag control - from pressure regulator
	204	'B' or 'C' supply to load bag relay valve
	205	'B' or 'C' supply to brake relay
	206	Service brake lockout signal line
	207	Steering lock signal line
	208	Steering lock supply line
	209	Steering stabilizer supply line
	210	Pusher axle laden-side control valve supply - from pressure protection valve
	211	Tee to unladen-side pressure regulator valve supply
	212	Laden-side control valve to pressure regulator valve
	213	Unladen-side pressure regulator valve to double check valve
	214	Laden-side pressure regulator valve to quick release valve
	215	Quick release valve to double check valve
	216	Double check valve to load-bag relay valve control
	217	Relay valve delivery to load-bags
	218	Skinner solenoid valve to automatic trans modulator cylinder
	219	Load air shocks - front
	220	Load air shocks - rear
	221	Fuel selector valve - supply line
	222	PTO control line - main transmission - mount PTO
	223	PTO control line - aux transmission or transfer case mount
	224	Front drive axle - driver controlled differential lock
	225	Air pressure gauge - rear suspension LH or single valve
	226	Air pressure gauge - rear suspension RH valve
	227	Air pressure gauge - single - accessory
	228	Tractor protection valve to pilot relay valve
	229	Brake valve 'A' to anti-compound DCV
	230	Boost tank to pilot relay valve (Australia)
	231	TPCS - supply line
	232	TPCS - PCU to front axle tee
	233	TPCS - front axle tee to inlet tube
	234	TPCS - PCU to rear axle frame tee
	235	TPCS - rear axle drop line
	236	TPCS - drop line to rear axle inlet tube
	237	TPCS - PCU to trailer connection
	239	Cab or combined Cab/Sleeper air ride supply
	240	Sleeper Air Ride Supply (when cab air ride is also used)
	241	External 'A' system service line - Glad-hands at front
	242	External emergency & park brake control - Glad-hands at front
	243	External Supply - Glad-hand to supply tank
	244	Supply air for Remote Park brake Release - 'B' tank to Solenoid valve
	245	Auxiliary air source outlets - Pressure protected
	246	Pintle Hitch air supply
	247	Dual connection to EOF - Service - Hard plumbed
	248	Dual connection to EOF - Emergency - Hard plumbed
Yellow/#8	249	'B' reservoir press. protection valve to under cab accessory manifold
	250	Rear relay delivery valve to inversion valve control port
	251	Air Supply to pressurized Bell Housing
	252	Receiver Tank to Governor
	253	Air Dryer Control to Air Dryer
	254	Air Dryer to Purge Tank
	255	Air Pressure Gauge - Trailer Suspension
	256	Pressure Supply to Outside Lift Axle Controls
	XS	Used for labeling extra air switches

Routed on chassis as a green #10 air line unlabeled

Airline Color/size	Airline Number	Airline Number Description
Green/#10	101	Supply to service 'A'
	151	Transmission - stationary / mobile control valve feed (s)

Description of air line location and function



WESTERN STAR

Air System - In Cab Lines All Models

Air systems schematics are located in Mod 880 and 883.

Refer to individual serial numbers for specific truck information systems using your dealer or service link.

No.	DESCRIPTION
1	COMPRESSOR
2	GOVERNOR
3	RESERVOIR - SUPPLY "SUPPLY"
4A	RESERVOIR - SUPPLY "A"
4B	RESERVOIR - SUPPLY "B"
4C	RESERVOIR - SUPPLY "C"
4D	RESERVOIR - SUPPLY "D"
5	RESERVOIR "EXTRA"
6	BRAKE VALVE
7	CHAMBER, SERVICE, CAM
7A	CHAMBER, SERVICE, WEDGE
8	CHAMBER, SERVICE, PARK , CAM
8A	CHAMBER, SERVICE, PARK WEDGE
9	
10	RELAY VALVE DUAL SUPPLY (5.5 PSI CRACK)
11	RELAY VALVE DUAL SUPPLY (4.0 PSI CRACK)
12	SINGLE CHECK VALVE
13	DOUBLE CHECK VALVE
14	QUICK RELEASE VALVE
15	FRAME TEE
16	TEE
17	AXLE TEE
18	PARK CONTROL VALVE SYSTEM
19	TPV CONTROL - TRAILER AIR SUPPLY
20	TPV (TRACTOR PROTECTION VALVE)
21	HAND CONTROL VALVE
22	SPRING BRAKE / INVERSION VALVE
23	ABS PMV (PRESSURE MODULATION VALVE)
24	ATC (ABS ANTISPIN VALVE)
25	AIR PRESSUR GAUGE (DUAL)
25A	AIR PRESSUR GAUGE (SINGLE)
26	DRAIN VALVE (SPITTER VALVE)
27	DRAIN COCK
28	STOP LAMP SWITCH
29	AIR DRYER
30	QR1-C (QUICK RELEASE / DBLE CHECK VALVE)
31	GLAD HAND
32	PASSTHROUGH MANIFOLD
33	IN-LINE FITTING
34	FRONT LIMITING VALVE
35	
36	PRESSURE RELIEF VALVE
37	PRESSURE PROTECTION VALVE
38	ADJUSTABLE PRESSURE REGULATOR
39	PRESET PRESSURE REGULATOR
40	CONTROL VALVE
41	BP-R1 (BOBTAIL VALVE)
42	DC-4 (DOUBLE CHECK VALVE)
43	DS-2 (DOUBLE CHECK VALVE)

PORT LEGEND	
SYMBOL	DESCRIPTION
S	SUPPLY
D	DELIVERY
C	CONTROL
E	EXHAUST
R	RESERVOIR
A	ACCESSORY

LINE SIZE LEGEND		
SYMBOL	NYLON	HOSE
△A	1/4	#4
△B	3/8	#6
△C	1/2	#8
△D	5/8	#10
△E	3/4	#12
△F	#8 TEFLON	
△G	1/8	NONE
△H	5/32	NONE

Basic Air System for Dual Hand Control Dash Valve

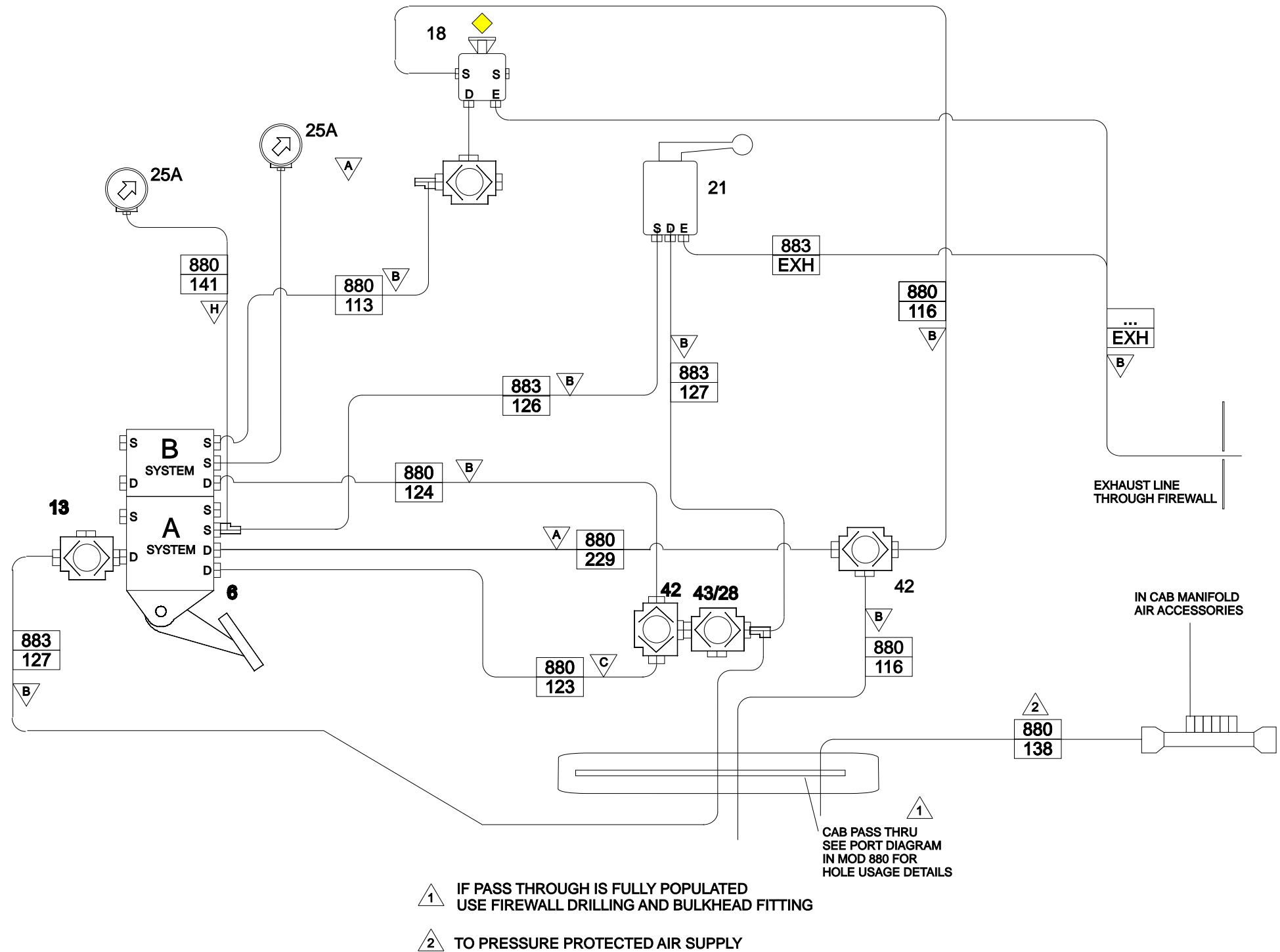



Utility Lights Check Models for Specific Availability



Std. Incandescent Lighting

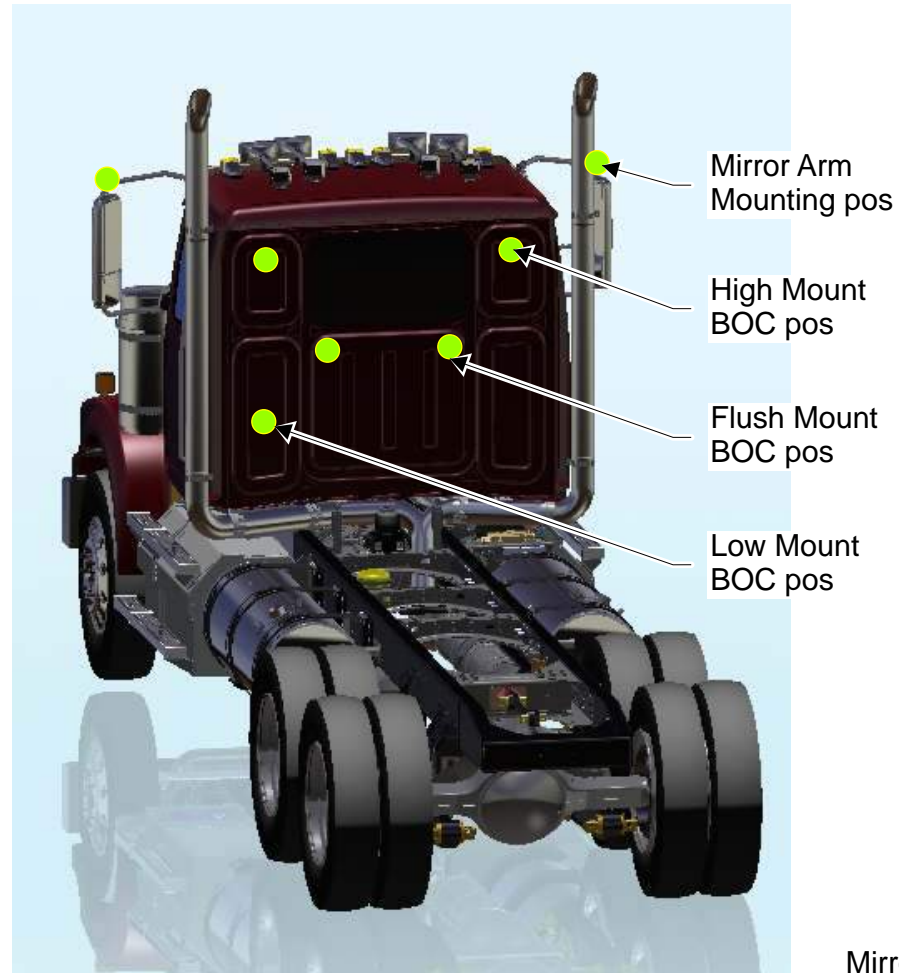

Incandescent	Package Description
31K-1A1	(2) Chrome incandescent utility lights with stainless steel anti-glare shields mounted on mirror arms
318-1BY	(2) Chrome swivel incandescent utility lights mounted LH and RH high on painted brackets back of cab
318-096	(2) Chrome swivel incandescent utility lights mounted low inboard on side extenders
318-1B0	(2) Chrome swivel incandescent utility lights mounted LH and RH high on stainless steel brackets back of sleeper
318-052	(2) Chrome swivel incandescent utility lights mounted high inboard on side extenders
318-085	(2) Swivel incandescent utility lights high inboard on side extenders and (2) flush mounted incandescent back of cab/sleeper
318-1AB	(2) Chrome swivel incandescent utility lights mounted low inboard on side extenders and (2) flush incandescent utility lights mounted back of cab/sleeper
318-1CG	(4) Utility lights: (2) chrome swivel incandescent mounted LH and RH high on stainless steel brackets back of sleeper and (2) flush mounted incandescent back of sleeper
318-1BX	(3) Chrome swivel incandescent utility lights: (2) mounted high on painted brackets LH and RH back of cab and (1) incandescent mounted low on painted bracket back of cab LH side
318-1CK	(1) Chrome swivel incandescent utility light mounted LH high on painted bracket back of cab
318-1CR	(1) Chrome swivel incandescent utility light mounted RH high on painted bracket back of cab
318-003	(1) Flush utility light mounted LH back of cab/sleeper
318-004	(2) Flush utility lights mounted back of cab/sleeper

LED Lighting

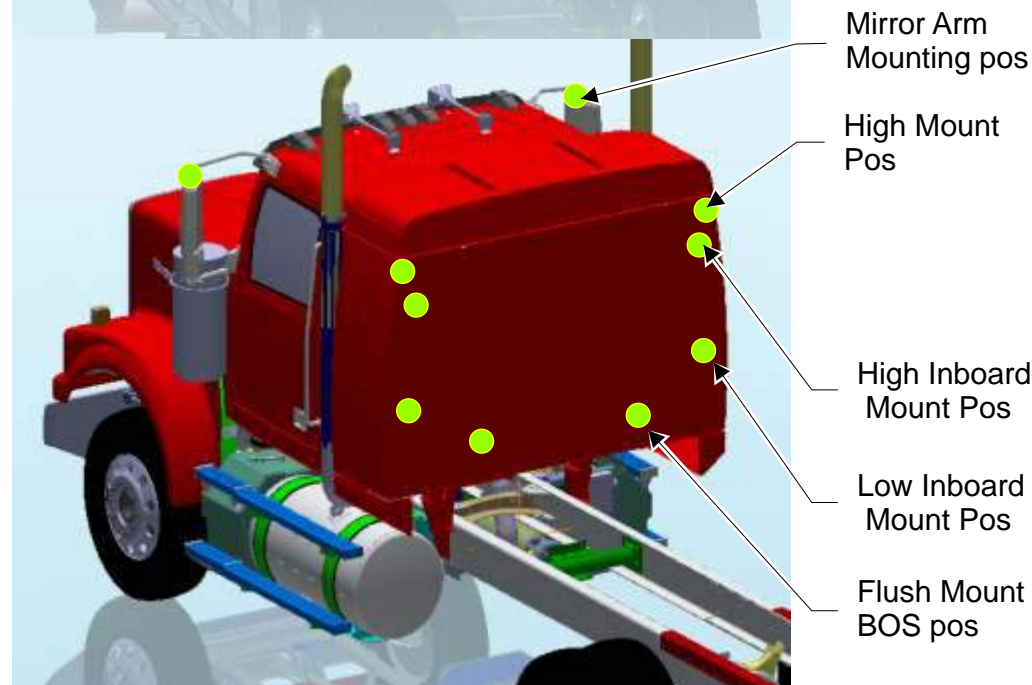

New LED	Package Description
31K-001	(2) Chrome LED utility lights with stainless steel anti-glare shields mounted on mirror arms
318-1D9	(2) Chrome swivel LED utility lights mounted LH and RH high on painted brackets back of cab
318-1E0	(2) Chrome swivel LED utility lights mounted low inboard on side extenders
318-1E1	(2) Chrome swivel LED utility lights mounted LH and RH high on stainless steel brackets back of sleeper
318-1E2	(2) Chrome swivel LED utility lights mounted high inboard on side extenders
318-1E3	(2) Swivel LED utility lights high inboard on side extenders and (2) flush mounted back of cab/sleeper
318-1E4	(2) Chrome swivel LED utility lights mounted low inboard on side extenders and (2) flush incandescent utility lights mounted back of cab/sleeper
318-1E5	(4) Utility lights: (2) chrome swivel LED mounted LH and RH high on stainless steel brackets back of sleeper and (2) flush mounted incandescent back of sleeper
318-1E6	(3) Chrome swivel LED utility lights: (2) mounted high on painted brackets LH and RH back of cab and (1) mounted low on painted bracket back of cab LH side
318-1E7	(1) Chrome swivel LED utility light mounted LH high on painted bracket back of cab
318-1E8	(1) Chrome swivel LED utility light mounted RH high on painted bracket back of cab

Turn Signal and Brake Override Circuit Elimination

Western Star Trucks turn signal switches are equipped with a brake override circuit. This circuit is designed to deactivate the 4-way flashers when the brakes are applied. In some vocations, customers prefer that the 4-way flashers remain flashing during use of the service brakes. To disable this feature, the red jumper wire located in the turn signal switch housing, used to activate this circuit needs simply to be cut and the ends taped or heat shrunk to remove this function. Both methods of wiring comply fully with Canada and USA regulations.

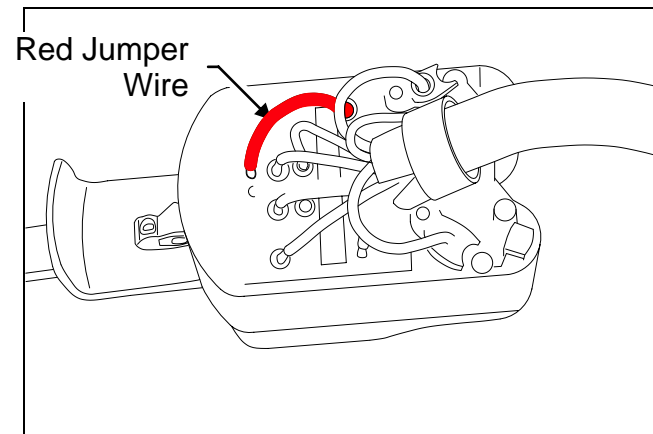

Installing Aftermarket LED Tail lights

Adding LED Tail Lights requires the addition of a 2 W 560 OHM resistor to ensure that the system consumes enough amperage for the system to function properly. Use the splice instructions below for installation of the aftermarket resistor.

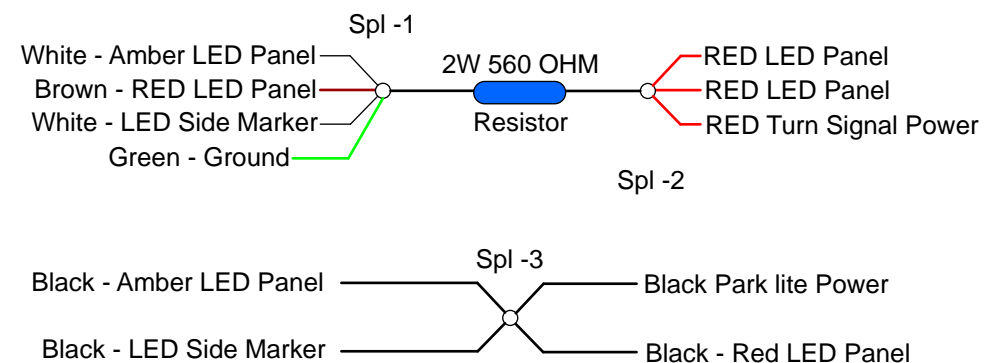

Disconnecting Daytime Running Lights

1. Shut down the engine, set the parking brake, and chock the tires.
2. Disconnect the negative leads from the batteries.
3. Remove the four screws that secure the instrument panel, then pull the top of the panel forward to access instrument panel wiring.
- 3A. On vehicles with fixed steering columns, remove the bolts that hold the steering column to the dash assembly to lower the steering column for access.
4. Disconnect the light gray **PECV** connector from the left-hand side of the Electronic Control Center (**ECC**).
5. Find wire labeled **LB08A** in cavity **A10**, and remove it using a connector tool.
6. Tag the wire with that location for future reinstallation.
7. Heat shrink or wrap the terminal end of the wire with electrical tape to prevent unintended connection, then secure the wire back to the harness with a tie-strap.
7. Connect the **PECV** connector to the left-hand side of the **ECC**.
8. Disconnect the dark gray **PECP** connector from the left-hand side of the **ECC**.
9. Find wire labeled **HL08H** (this wire may also be labeled **HL05B** in later models) located in in **cavity G**, and tag the wire with that location for future reinstallation.
10. Remove the wire from the connector, wrap the terminal of the wire with electrical tape to prevent unintended connection, then secure the wire back to the harness with a tie-strap.
11. Connect the **PECP** connector to the left-hand side of the **ECC**.
12. Position the instrument panel and install the screws. If the steering column was lowered, position it into place, and tighten the steering column capscrews 17 lbf·ft (23 N·m).
13. Connect the batteries.
14. Verify correct operation of the lights.

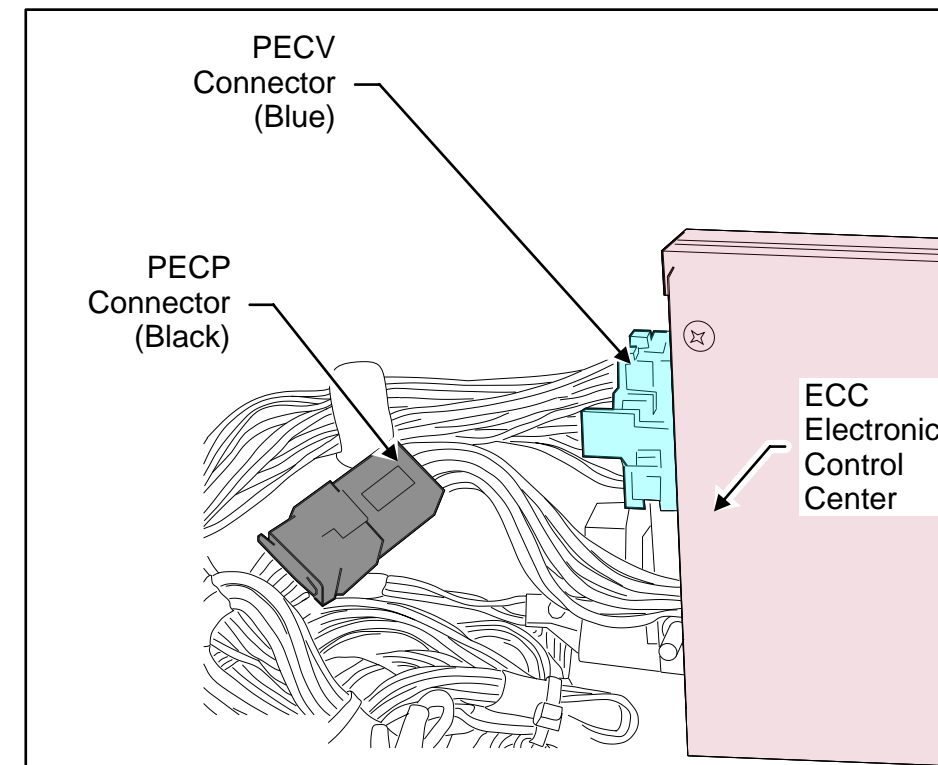



4800/4900/6900 Tail Lights

Protected Under Frame Vocational Tail lights

Taillight units are well protected and mounted under end of from crossmember

294-054 Vsm dual sealed logger light bar mounted stop/tail/turn/backup lights

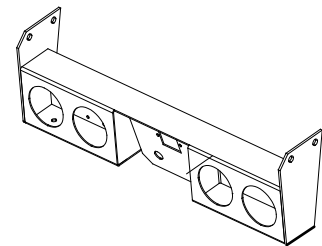
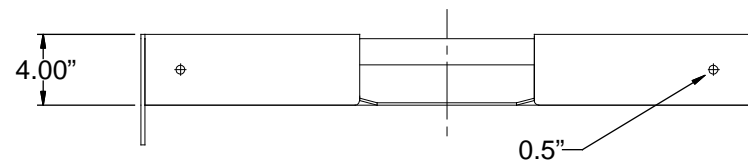
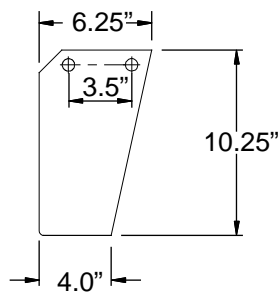
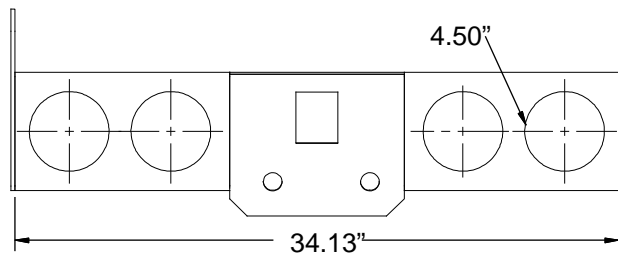

Fully Protected Tail lights Mounted Outside of Frame

Taillight units are fully boxed in on all sides by a simple sturdy box housing mounted on the outside of the frame

294-053 Vsm dual sealed outboard of rail mounted stop/tail/turn/backup lights

294-057 Grote torsion mount sealed stop/tail/turn lights in boxes outside of frame

294-079 LED stop/tail with separate backup lights mounted in boxes outboard of rail

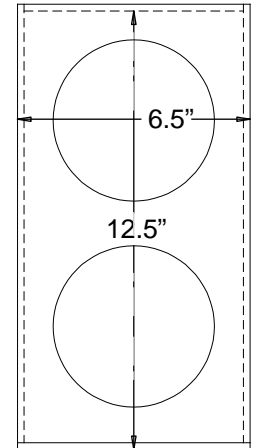
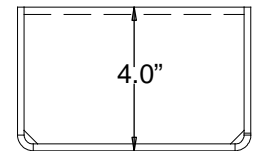

Fully Protected Separate Tail Lights Mounted Outside of Frame

Taillight units are fully boxed in on all sides by a simple sturdy box housing and mounted under the end of frame

294-082 LED stop/tail with separate backup lights mounted in box under end of frame

294-055 Grote torsion mount sealed stop/tail/turn lights in box below tear crossmember

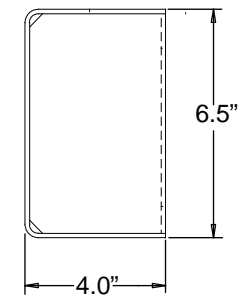
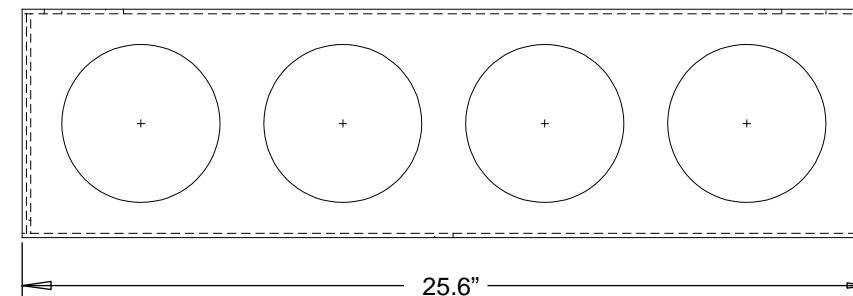

4800/4900/6900 Tail Light Configurations

Unprotected Single Unit Tail lights

Taillight units are unprotected and mounted off brackets located on end of from crossmember

294-032 Flush mounted stop/tail/backup lights mounted below rear most crossmember

294-1AJ Boxed tail light assembly with **LED** stop/tail/license plate lights and incandescent backup lights mounted below rear most Crossmember



Partially protected Single Unit Tail lights mounted Outside of Frame

Taillight units are protected on three sides by a simple open box housing mounted on the outside of the frame

294-049 Boxed tail lights (stop/tail/backup) mounted outboard of rails

294-052 Vsm dual sealed inboard of rail mounted stop/tail/turn/backup lights

294-1AC Boxed tail light assembly (stop/tail/backup) mounted outboard of rails and inset 4" from end of frame

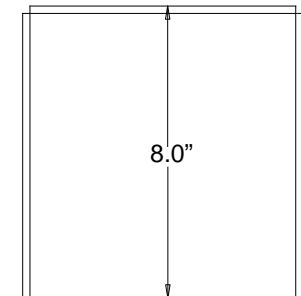
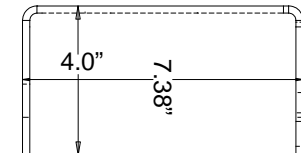

Partially protected Single Unit Tail lights mounted Under Frame

Taillight units are protected on three sides by a simple open box housing Mounted under the end of frame

294-040 Boxed tail light (stop/tail/backup) mounted below the rails

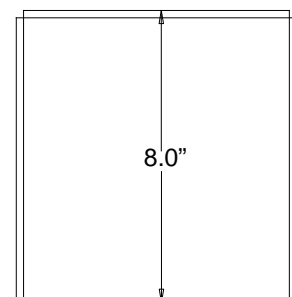
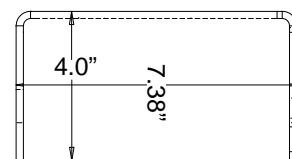

Partially Protected Single Unit Tail Lights Under Frame

Taillight units are supported from a simple angle plate mounted under end of from crossmember

294-060 LED stop/tail with separate backup lights mounted on polished aluminum plate end of frame

294-063 Vsm dual sealed polished aluminum plate mounted stop/tail/turn/backup lights

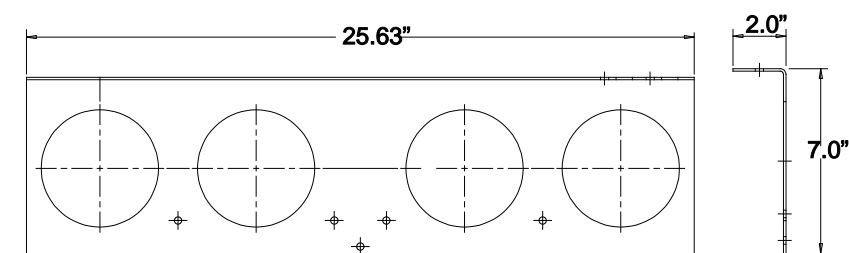



4700 DCC Tail Lights

294-1AV LED stop/tail with separate led backup lights mounted on painted steel plate end of frame

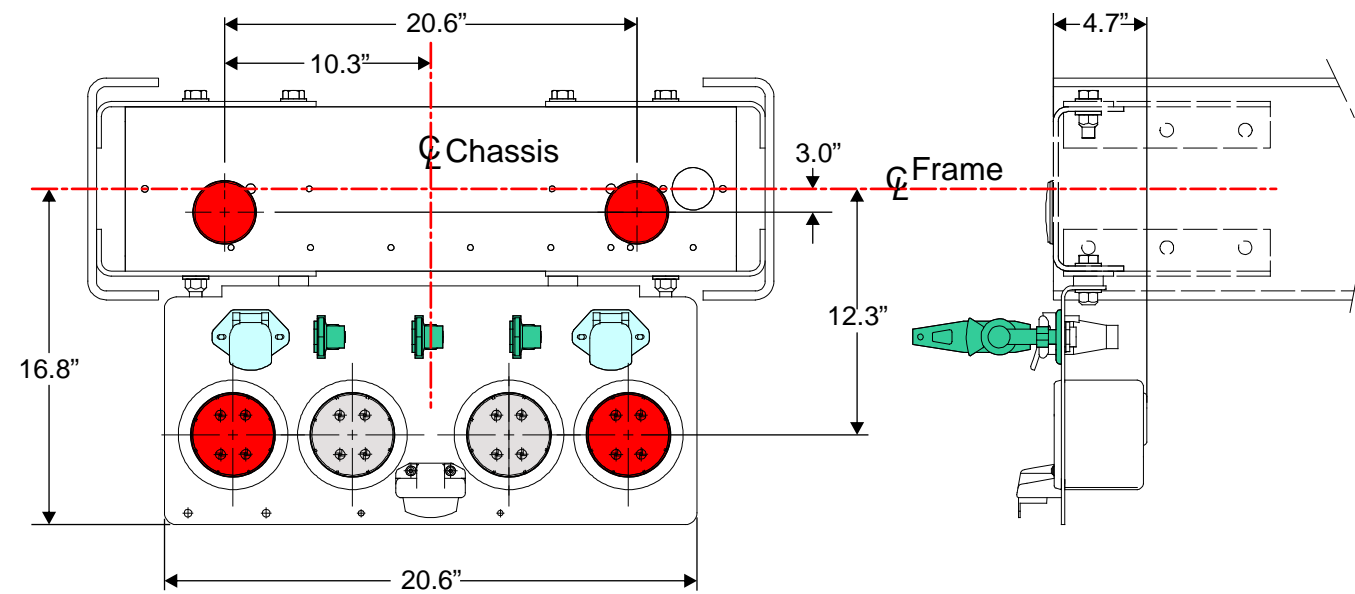

294-001 Integral stop / tail / backup lights with Deep V EOF

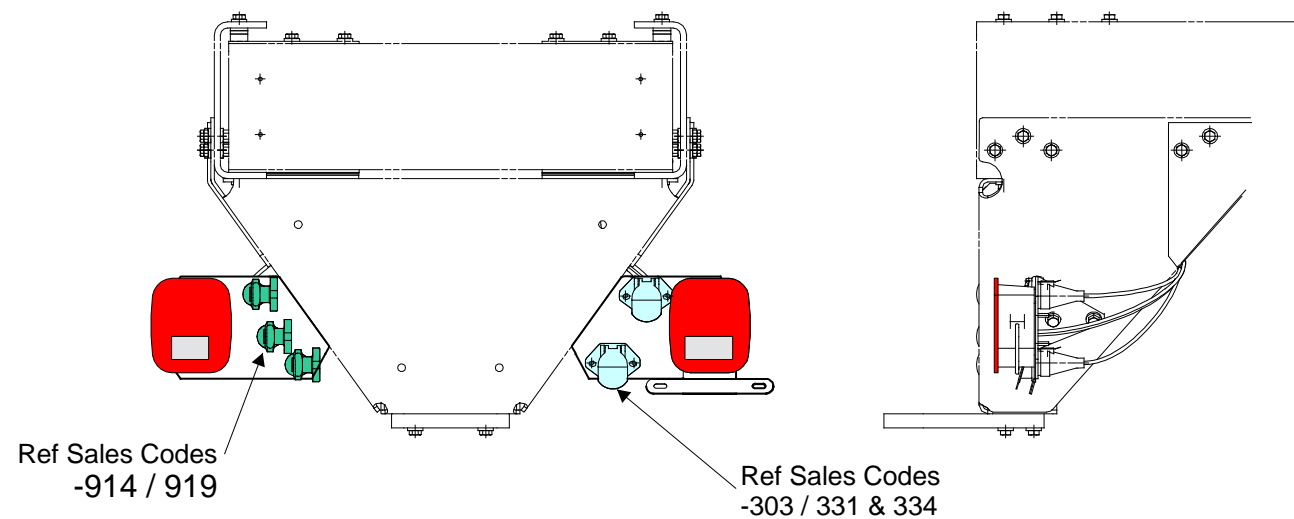

Ref Sales Codes
-914 / 919

Ref Sales Codes
-303 / 331 & 334

294-001 Integral stop / tail / backup lights with STD EOF

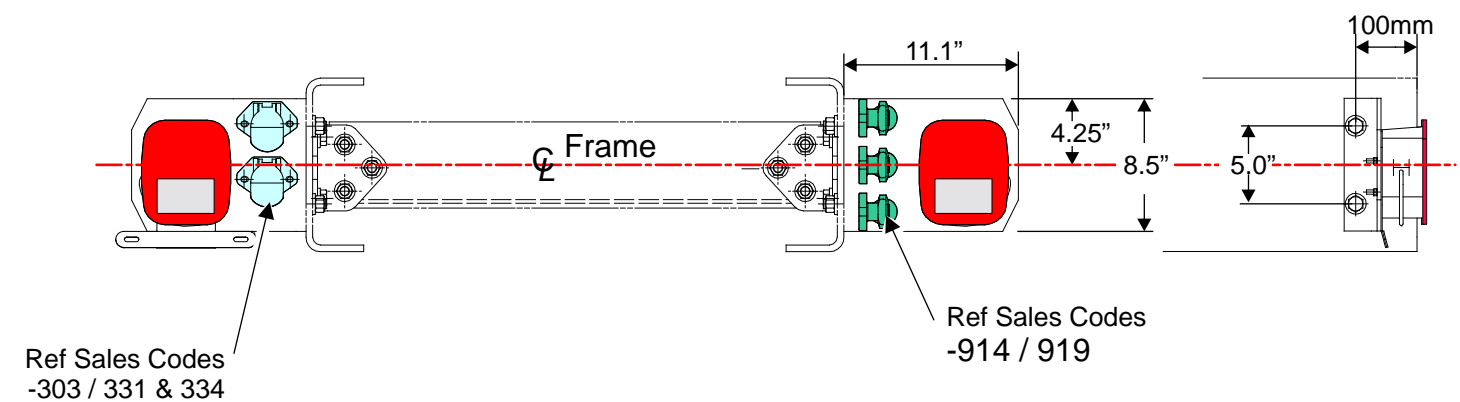

Ref Sales Codes
-303 / 331 & 334

Ref Sales Codes
-914 / 919